



Marion County Board of County Commissioners

601 S.E. 25th Avenue, Ocala, Florida 34471-2690 (352) 620-3307 -- Suncom (352) 667-3307 -- Fax (352) 620-3392

COMMISSIONERS

- JUDY JOHNSON DIST. 1
LARRY CRETUL DIST. 2
PARNELL TOWNLEY DIST. 3
RANDY HARRIS DIST. 4
STEVE F. HENNING DIST. 5

April 29, 1998

Blanca S. Bayo, Director, Division of Records and Reporting
FLORIDA PUBLIC SERVICE COMMISSION
2540 Shumard Oak Boulevard
Tallahassee, FL 32399-0850

Re: Notice of Objection to Application for Amendment of Certificate Nos. 373-W and 322-S, Docket No. 980467-WS, and Request for Hearing

98 MAY -1 AM 10:35 MAIL ROOM RECEIVED FLORIDA PUBLIC SERVICE COMMISSION

Dear Ms. Bayo:

As Chairman I am writing this letter on behalf of the Board of County Commissioners of Marion County to object to Florida Water Services Corporation's Application for Amendment of Certificate Nos. 373-W and 322-S. Marion County is a political subdivision of the State of Florida, whose address is 601 SE 25th Avenue, Ocala, Florida 34471-2690. Any notices, pleadings and correspondence regarding this matter should be sent to Gordon B. Johnston, County Attorney, Marion County Attorneys Office at the address given above.

Marion County objects to a portion of Florida Water Services Corporation's ("FWSC") request to amend its water and sewer certificated service areas. The portion of proposed water and sewer service areas to which Marion County objects are depicted on the maps attached and incorporated in this letter objection as Exhibits "A" and "B." Marion County does not object to those proposed service areas on these two maps which are not so specified as areas of "County Objection."

- ACK []
AFA []
APP []
CAF []
CMU []
CTR []
EAG []
LEG []
LIN []
OPC []
RCH []
SEC []
WAS []
OTH []

Handwritten notes: '1' next to LEG, 'Exhs A+B to WAW' next to OTH.

DOCUMENT NUMBER-DATE
04935 MAY-1 98
FPSC-RECORDS/REPORTING

system in competition with or duplication of other systems, (5) water and sewer service exists from other sources within geographical proximity to the areas FWSC seeks to add, (6) FWSC's proposed certificate amendments are inconsistent with Marion County's Comprehensive Plan, and (7) it is not in the public interest to grant FWSC's amendment application with respect to the areas to which the County objects. Marion County also believes that granting the proposed service area extensions in the "County Objection" areas will interfere with and violate the terms under which FWSC's parent corporation was allowed to acquire control of this utility as set forth in Florida Public Service Commission Order No. 22307, dated December 12, 1989 in Docket No. 881501-WS.

With respect to the "County Objection" area, Marion County disputes whether: (1) FWSC's application is consistent with the Marion County Comprehensive Plan and associated documents, (2) FWSC has the financial ability to provide the service for the area requested, (3) there is a need for water and sewer service for the area requested, (4) the application for certificate amendment is adequate, complete, and complies with all requirements, (5) FWSC has adequate water and sewer capacity in its facilities to meet present and future needs, (6) the proposed amendment will result in an extension of a system not in competition with or duplication of other systems, (7) water and sewer service does not exist from other sources within geographic proximity to the areas sought to be added, (8) FWSC's application complies with FPSC Order No. 22307, and (9) this application is in the public interest.

Marion County's substantial interests will be affected by the proposed extension requested by FWSC for the following reasons: (1) as a provider of water and sewer services in Marion County, the County's interest may be materially, substantially and adversely affected by the approval of that portion of the extension objected to by the County, (2) in the event that FWSC's request is granted, FWSC will be a designated provider of water and sewer service for the areas so designated and the residents therein and Marion County may be precluded from providing both water and sewer service at better quality and less costs, (3) if FWSC is not financially able to provide adequate service, the areas designated for service by FWSC and the residents therein will be left without a water and sewer provider, (4) Marion County is presently contractually committed to providing water and sewer service in a portion of the area. That contract is the Marion County/Ocala Meadows Subregional Water and Wastewater Utilities Agreement, Contract No. 96-3 attached to and incorporated in this letter objection as Exhibit "C," and (5) engineering has been completed and permits have been obtained for subregional water and wastewater facilities contractually committed to be owned by Marion County which are capable of serving a portion of the area to which FWSC is seeking to serve.

Blanca S. Bayo, Director, of Records and Reporting
April 29, 1998
Page 3

By this letter, Marion County requests that the FPSC recognize this objection and accord Marion County full party status in this proceeding with all rights attendant thereto, and that a hearing be convened to examine FWSC's Application for Certificate Nos. 373-W and 322-S, to add territory in Marion County, Florida, that Marion County be allowed present evidence, testimony, and cross-examine witnesses presented by other parties to this action, and that portion of FWSC's Application for Amendment to which the County has objected be denied. Marion County believes it is entitled to relief under the provision of Chapter 367 and 120, F.S., and the Rules of the Florida Public Service Commission.

As indicated above, please direct all correspondence regarding this matter to the Marion County Attorney, Gordon B. Johnston, at the address indicated above. On behalf of the Board of County Commissioners of Marion County, I am,

Sincerely,

A handwritten signature in black ink, appearing to read "Randy Harris", with a horizontal line extending to the right.

Randy Harris, Chairman
Marion County Board of County Commissioners

Enclosures

cc: Brian Armstrong, Vice President and General Counsel, FWSC
Gordon B. Johnston, County Attorney, Marion County

Exhibit C

THIS INSTRUMENT PREPARED BY
AND SHOULD BE RETURNED TO:

Thomas A. Cloud, Esq.
GRAY HARRIS & ROBINSON, P.A.
201 East Pine Street, Suite 1200
Post Office Box 3068
Orlando, FL 32802-3068
(407) 843-8880

DAVID R. ELLSPERMANN, CLERK OF CIRCUIT COURT
 FILE: 97103547
 12/24/97 08:52
 OR BOOK/PAGE: 2444/843
 MARION COUNTY

For Recording Purposes Only

County Atty
 601 S.E. 25th Ave.
 Ocala, Fl. 34471

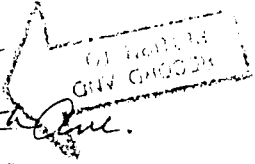

**MARION COUNTY/OCALA MEADOWS
 SUBREGIONAL WATER AND WASTEWATER
 UTILITIES AGREEMENT
 CONTRACT NO. 96-03**

THIS AGREEMENT is made this 1st day of OCTOBER, 1996, by **MARION COUNTY**, a political subdivision of the State of Florida (hereafter "COUNTY"), and **S. PLATO KIRBY, JR.**, an individual, **BENETA KIRBY**, an individual, **M.D. PERRY**, an individual, and **FRANCES O. PERRY**, an individual (hereinafter collectively the "CONTRACT SELLER"), and **SIEMENS OCALA CORP.**, a Florida corporation (hereinafter the "CONTRACT PURCHASER"). The CONTRACT SELLERS and the CONTRACT PURCHASER shall hereafter be collectively referred to as the "OWNER".)

RECITALS

1. CONTRACT SELLER now owns, or has a valid contract or option to purchase certain real property in Marion County, Florida, more particularly described in the legal description attached to and incorporated in this Agreement as Composite Exhibit "A." The above-described property consists of approximately 461 acres of land and shall hereinafter be referred to as the "Property."

2. OWNER will require substantial water and wastewater service for future development of the Property. Water service and Wastewater Service Capacities for development on the Property will be provided by the construction and expansion of the Marion County Water and Wastewater System, as further described herein.

3. Water and Wastewater Service Capacities for the development on the Property shall be provided in the manner described below and subject to the terms and conditions provided herein.

4. The COUNTY is willing to provide water and wastewater service capacities to OWNER in accordance with, and subject to, the terms and conditions of this Agreement, and any applicable rules, regulations, laws, and requirements.

5. A golf course will be developed on the property, and a lake is currently located upon the Property. These items lend themselves to the creation of various Effluent Disposal Facilities.

6. The parties wish to set forth the terms and conditions upon which OWNER would transfer those lands, easements, and facilities necessary for the COUNTY to provide Water and Wastewater Service Capacities to OWNER.

7. The parties wish to set forth the terms and conditions upon which OWNER will transfer certain lands, easements, and facilities, including effluent disposal easements upon the golf course to be developed on the Property.

8. In return for OWNER'S transfer of these certain lands, easements, and facilities, to the COUNTY, OWNER shall be entitled to credits against the COUNTY'S capital charges as set forth below.

9. OWNER will construct Water Treatment Facilities, Water Distribution Facilities, Collection and Transmission Facilities, Wastewater Treatment Facilities and Effluent Disposal Facilities as herein described.

10. The parties now desire to reduce their agreements to writing into this Agreement for the purpose of setting forth the rights, obligations, and duties of the parties as the same pertains to the provision of Water and Wastewater Service capacities for future development on the Property.

ACCORDINGLY, in consideration of the Recitals hereof, for and in and in consideration of the mutual undertakings and agreements herein contained and assumed and other good and valuable considerations received by each party from the other, the receipt and sufficiency of which are hereby acknowledged, the parties do hereby agree as follows:

FILE: 97103547
OR BOOK/PAGE: 2444 / B44

SECTION 1. RECITALS. The above recitals are true and correct, and form a material part of this Agreement.

SECTION 2. DEFINITIONS. The parties agree that in construing this Agreement, the following words, phrases, and terms shall have the following meanings unless the context indicates otherwise.

2.1. "Agreement" means this MARION COUNTY/OCALA MEADOWS SUBREGIONAL WATER AND WASTEWATER UTILITIES AGREEMENT CONTRACT NO. 96-03, as it may from time to time be modified.

2.2. "Collection and Transmission Facilities" means the lines, pipes and appurtenant equipment used to collect Wastewater from the Property and to transmit it to the Wastewater Treatment Facilities.

2.3. "COUNTY" means Marion County, Florida, a political subdivision of the State.

2.4. "County Rate Resolutions and Ordinances" means all resolutions and ordinances, either currently in effect or to be adopted in the future by the Board of County Commissioners of the COUNTY or its successors which establish and fix rates, fees, and charges for the Marion County Water System and the Marion County Wastewater System or successor systems.

2.5. "Effluent Disposal Capacity" means the rate of treated effluent flow, measured in GPD, for which the Effluent Disposal Facilities are designed and are capable of disposing, in accordance with all applicable government requirements.

2.6. "Effluent Disposal Facilities" means those Wastewater Facilities necessary to detain, transmit, and dispose of wastewater previously treated at the Wastewater Treatment Facilities.

2.7. "ERC" means an Equivalent Residential Connection as defined by Marion County Rate Resolutions and Ordinances.

2.8. "Facilities" means the Water Facilities and Wastewater Facilities.

2.9. "Future Development" means the development on the Property that may be approved subsequent to the date of this Agreement.

2.10. "GPD" means gallons per day on an average annual basis.

2.11. "Marion County Wastewater System" means all facilities and interests in real and personal property owned, operated, managed or controlled by the COUNTY

now and in the future and used to provide Wastewater Service capacity to existing and future customers within the total service area of the COUNTY.

2.12. "Marion County Water System" means all facilities and interests in real and personal property owned, operated, managed or controlled by the COUNTY now and in the future and used to provide Water Service capacity to existing and future customers within the total service area of the COUNTY.

2.13. "Plans and Specifications" means those documents and drawings prepared by OWNER's engineer for the design and construction of certain Collection and Transmission Facilities, Wastewater Treatment Facilities, Effluent Disposal Facilities, Water Treatment Facilities and Water Distribution Facilities.

2.14. "Potable Water" means water that has been treated to applicable federal, state and local standards that is acceptable for human consumption.

2.15. "Wastewater" means water-carried wastes from residences, business buildings, institutions, industrial establishments and other customers of the Marion County Wastewater System.

2.16. "Wastewater Facilities" means all wastewater Collection and Transmission, Wastewater Treatment, and Effluent Disposal Facilities, including all interceptors, lines, pipes, meters, couplings, pumps, force mains, and appurtenant equipment. The Wastewater Facilities also includes an eight-inch (8") diameter raw wastewater force main to the Wastewater Treatment Facilities site and an eight-inch (8") diameter reclaimed water/effluent Effluent Disposal Facilities easement.

2.17. "Wastewater Capital Charges" means those fees and charges established and collected by the COUNTY at or before the issuance of building permits or certificates of occupancy to pay for or recover the capital costs of all Wastewater Facilities, as set forth from time to time in COUNTY Rate Resolutions and Ordinances.

2.18. "Wastewater Service Capacity" means the rate of wastewater flow measured in GPD for which Wastewater Facilities are designed and are capable of collecting, transmitting, treating and disposing, in accordance with applicable governmental requirements and regulations.

2.19. "Wastewater Treatment Facilities" means those components of the Wastewater Facilities used to treat and filter wastewater prior to effluent disposal. Wastewater Treatment Facilities do not include any portions of the Collection and Transmission Facilities, or Effluent Disposal Facilities. The Wastewater Treatment Facilities shall be constructed on land not within the Property to be provided by the OWNER. The initial conceptual Wastewater Treatment Facilities plant specifications are projected as set forth in Exhibit "B" attached to and incorporated in this Agreement.

2.20. "Water Capital Charges" means those fees and charges established and collected by the COUNTY at or before the issuance of building permits or certificates of occupancy to pay for or recover the capital cost of all water facilities, as set forth from time to time in COUNTY Rate Resolutions and Ordinances.

2.21. "Water Distribution Facilities" means all lines, meters, pipes, and appurtenant equipment necessary to distribute potable water from the Water Treatment Facilities to the structures to be served, all in accordance with COUNTY rules and regulations.

2.22. "Water Facilities" means all Water Distribution and Water Treatment Facilities.

2.23. "Water Service Capacity" means the rate of water which can be pumped from the ground, treated to become potable, transmitted and distributed, where such amount is measured in gallons per day, based upon maximum daily domestic demand and fire flows.

2.24. "Water Treatment Facilities" means those facilities necessary to properly treat water to potable standards and store water prior to transmission and distribution. The initial conceptual Water Treatment Facilities plant specifications are projected to be as set forth in Exhibit "B" hereof.

SECTION 3. PROVISION OF WATER AND WASTEWATER SERVICE GENERALLY. Subject to the terms of this Agreement, the COUNTY agrees that it will provide and OWNER agrees that it will obtain Water Service Capacity and Wastewater Service Capacity for use on the Property from the COUNTY. The COUNTY plans on providing Water Service Capacity under this Agreement by means of operating and maintaining subregional Water Treatment Facilities constructed by OWNER and plans on providing Wastewater Service Capacity under this Agreement by means of operating and maintaining subregional Wastewater Treatment Facilities constructed by OWNER which shall become part of the Marion County Wastewater System. OWNER shall convey certain lands, facilities, and easements to the COUNTY as set forth hereinbelow, and shall pay all applicable rates, fees, and charges in accordance with County Rate Resolutions and Ordinances; provided, however, that OWNER shall be entitled to certain credits against Water and Wastewater Capital Charges as set forth below.

SECTION 4. DESIGN, CONSTRUCTION, AND OPERATION OF WATER FACILITIES AND WASTEWATER FACILITIES. OWNER agrees as a condition precedent to its receipt of Water and Wastewater Service Capacities for use on the Property to do the following:

4.1. Design of Water Facilities and Wastewater Facilities. The OWNER's engineer has previously submitted flow diagrams and plant site plans for Water Treatment Facilities and Wastewater Treatment Facilities, which are attached to and incorporated in this Agreement as Exhibit "C." OWNER shall have the right, at its expense, to cause its own Florida registered professional engineer to design and produce and submit to the COUNTY for its review and approval prior to construction, graphic Plans and Specifications in accordance with COUNTY requirements for the construction of those certain Water Distribution Facilities, Water Treatment Facilities, Collection and Transmission Facilities, Wastewater Treatment Facilities, and Effluent Disposal Facilities (hereinafter collectively referred to as the "Facilities"). The Plans and Specifications for the: (1) Water Facilities shall be done in one (1) phase of GPD for Water Service Capacity for a total of 400,000 GPD of Water Service Capacity plus fire flow of 2,000 GPM on a 2-hour duration basis consistent with OWNER's Future Development; and (2) Water Distribution Facility shall be done in multiple phases. The Plans and Specifications for the: (1) Wastewater Treatment Facilities shall be done in two (2) phases of 165,000 GPD Wastewater Service Capacity each, for a total of 330,000 GPD of Wastewater Service Capacity; and (2) Collection and Transmission Facilities shall be done in multiple phases.

4.2. Approval of Plans and Specifications for Water Facilities and Wastewater Facilities. The COUNTY shall review, and reject or approve, any such Plans and Specifications submitted pursuant to Subsection 4.1 hereof within forty-five (45) days after its receipt of the Plans and Specifications. OWNER's engineers shall make corrections or modifications at OWNER's expense to any portion of the Plans and Specifications which are unacceptable to the COUNTY, and shall resubmit the corrected or modified Plans and Specifications to the COUNTY for further review until COUNTY shall have approved the Plans and Specifications. The COUNTY shall have, in each case, fifteen (15) days within which to approve or reject any such revision to said Plans and Specifications. Any such submitted Plans and Specifications which are not approved or rejected within the time period provided shall be deemed approved.

4.3. Permitting. OWNER shall, at its expense, obtain all necessary state and local permits or approvals required for the construction of the said Facilities to be constructed pursuant to this Agreement. OWNER shall send written copies of all permit applications filed with state or local governmental entities, to the COUNTY, and shall also provide the COUNTY with copies of all written permits, approvals, requests for additional information, or denials received by OWNER in connection with such permit applications.

4.4. Construction of Facilities. After COUNTY approval of the Plans and Specifications for any phase or segment of the said Facilities, OWNER shall, at its expense, construct and install that phase or segment of the said Facilities as the same are depicted in the COUNTY-approved Plans and Specifications therefor. OWNER warrants that the said Facilities to be constructed by it pursuant to this Agreement shall be constructed in accordance with the approved Plans and Specifications, and also in accordance with all other applicable federal, state, and local laws, regulations, rules and

ordinances including but not limited to the design criteria promulgated by COUNTY. After completion of construction and prior to acceptance or approval of such Facilities by COUNTY, OWNER agrees to furnish to COUNTY one (1) set of Mylar "as built" drawings showing specification locations, depth, and other appropriate details of all Facilities.

4.5. Inspection, Testing, and Approval of Construction. During the construction of the said Facilities by OWNER, the COUNTY shall have the continuing right to inspect such installations to determine compliance with the Plans and Specifications. The COUNTY shall control the quality of the installation, and further, shall be entitled to perform standard tests for pressure, exfiltration, infiltration, line and grade, and all other normal engineering tests to determine that the system has been installed in accordance with the Plans and Specification and good engineering, practices.

4.6. Conveyance or Dedication of Facilities and Easements. Prior to acceptance of any phase or segment of the said Facilities for ownership, operation and maintenance by the COUNTY, OWNER shall, with the respect to such phase or segment constructed or otherwise provided by OWNER, (1) convey, grant or dedicate to the COUNTY free and clear of any encumbrances whatsoever, such easements as are reasonably necessary for the COUNTY to own, operate, maintain, repair, expand, and replace the said Facilities accepted by the COUNTY, including all said Facilities constructed thereon, (2) transfer and convey fee simple title to those certain Water Facilities and Wastewater Facilities sites, as set forth in more detail in Section 5, herein, and (3) transfer and convey, to the extent that the same are transferable, all governmental approvals and permits that will enable the COUNTY to operate the applicable phase or portion of those said Facilities and provide Water and Wastewater Service Capacity to Future Development on the Property, and notify all governmental agencies of such transfer and conveyance as may be required by law. The COUNTY shall review and, if consistent with the COUNTY-approved design thereof and terms of this Agreement, shall approve or reject within thirty (30) days after receipt thereof, all documents submitted by OWNER pursuant to this Agreement.

Handwritten signatures and initials:
BTK
MP
J.D.P.
SJ

4.7. Characterization and Surrender of Water and Wastewater Facilities. Upon acceptance by the COUNTY of any said Facilities as aforesaid, the accepted facilities shall become part of the Marion County Water and Wastewater Systems, as appropriate, and OWNER shall surrender control of said Facilities and execute and deliver to the COUNTY any documents or instruments necessary for that purpose. If OWNER shall fail or refuse to do so, then the COUNTY shall be entitled to specifically enforce the provisions of this Subsection 4.7 against OWNER.

4.8. Effect of Reviews, Inspections Approvals, and Acceptances. The reviews, inspections, approvals, and acceptances by the COUNTY of the Plans and Specifications and construction shall not constitute a waiver of any claims arising from (1) faulty or defective design, (2) faulty or defective construction, (3) unsettled liens and encumbrances, and (4) tort claims.

4.9. Operation and Maintenance of Water and Wastewater Facilities.

Subject to OWNER's compliance with this and other applicable provisions of this Agreement, the COUNTY or its successors shall in writing accept ownership and assume responsibility for the operation and maintenance of those said Facilities for which the COUNTY has approved the design, construction, and documents specified in this Section 4. Upon acceptance of ownership and assumption of the responsibility for the operation and maintenance of any such Water Facilities or Wastewater Facilities by the COUNTY as contemplated in this Agreement, all customers of those Water Facilities or Wastewater Facilities shall be deemed customers of the Marion County Water System or Marion County Wastewater System, as the case may be, and the COUNTY shall set and collect all wastewater rates, fees, charges and deposits for those Water Facilities, or Wastewater Facilities, as the case may be, without any exception except that set forth in Section 6.1 herein, in accordance with the COUNTY Rate Resolutions and Ordinances.

SECTION 5. EASEMENTS AND DEEDS.

5.1. Grant of Easements. OWNER hereby grants and gives to the COUNTY, its successors and assigns, subject to the terms of this Agreement, the exclusive right, privilege, and easement to construct, install, own, maintain, expand and operate the Water Facilities and Wastewater Facilities (hereafter "Facilities") in, under, upon, over and across the OWNER's Property to serve the OWNER's Property. OWNER will, upon request of the COUNTY, execute specific easements to be recorded in the Public Records of Marion County, Florida. Upon establishment, a separate easement instrument shall be executed and delivered to the COUNTY by OWNER which is the functional equivalent of this Section; provided, however, that instead of a "blanket" easement, the easement shall only cover those portions of the Property wherein lie any such Facilities. Likewise, OWNER hereby grants and gives to the COUNTY, its successors and assigns, subject to the terms of this Agreement, the right to construct, install, own, maintain, expand, and operate lines within existing and future street and road rights-of-way or easements within the Property or through the Property to other lands. As a condition to acceptance of the Wastewater Treatment Facilities and Effluent Disposal Facilities, OWNER shall also convey to the COUNTY those certain effluent disposal easements onto the golf course to be located within the Property, and wet weather storage easement within the existing lake and any artificial lakes or ponds to be constructed on the Property in areas conceptually depicted and set forth in Exhibit "D" attached to and incorporated in this Agreement. These effluent disposal and wet weather disposal easements shall be more particularly described for the COUNTY and shall be granted in form substantially the same as that form easement attached to and incorporated in this Agreement as Exhibit "E". OWNER will, upon request of the COUNTY, execute specific easements to be recorded in the Public Records of Marion County, Florida, in order to implement this easement obligation.

5.2. Rights of Ingress and Egress. The grants in Section 5 and the foregoing grants include the necessary right of ingress and egress to any part of the

OWNER's Property upon which COUNTY is constructing, operating or maintaining such Facilities, the foregoing grants shall be for such period of time as and to the fullest extent that COUNTY or its successors or assigns require such rights, privileges or easements in the construction, ownership, maintenance, operation, repair or expansion of said Facilities.

5.3. Errors in Line Locations. The COUNTY and OWNER will use due diligence in ascertaining all easement locations; however, should COUNTY or OWNER install any Facilities outside a dedicated easement area, COUNTY will not be required to move or relocate any such Facilities lying outside a dedicated easement area, or private easement area conveyed by express grant, so long as the Facilities do not interfere with the then or proposed use of the area in which the Facilities have been installed, and so long as the COUNTY obtains a private easement for such line location, which OWNER will give if same is within its reasonable power to do so. Should the COUNTY be obligated to relocate any such Facility installed by OWNER, then OWNER shall reimburse to the COUNTY, the COUNTY's costs reasonably incurred in connection with such relocation. The COUNTY shall be responsible for the relocation of any such Facility installed by the COUNTY.

5.4. Utilization of Easement Grants. The COUNTY agrees that all easement grants will be utilized in accordance with the established and generally accepted practices of the water and wastewater industry with respect to the installation of all such Facilities in any of the easement areas to serve the OWNER's Property and the property of others in accordance with the Master Plan; and that OWNER or OWNER's successors or assigns in granting any easement herein, or pursuant to the terms of this instrument, shall have the right to grant exclusive or non-exclusive rights, privileges and easements to other persons, firms or corporations to provide to the Property any utility services other than water and sewer service.

5.5. Title. All such easements shall be granted free and clear of all encumbrances whatsoever.

5.6. Deeds. As a condition to the COUNTY's acceptance of the Water Treatment Facilities, OWNER shall also convey fee simple title to at least a two (2) acre parcel located on the Property upon which the Water Treatment Facilities are to be constructed, which parcel is conceptually depicted as a five (5) acre parcel on Exhibit "D," which is attached hereto and incorporated herein by reference. OWNER also agrees at its expense to locate, submit for review, and upon approval convey a Wastewater Treatment Facilities site situated proximate to Property, consisting of no less than ten (10) acres and no more than fifteen (15) acres, and capable of accommodating the subregional Wastewater Treatment Facilities. The COUNTY shall review, and reject or approve said site within thirty (30) days after its receipt by the COUNTY. Which consent will not be unreasonably withheld. The OWNER shall likewise convey to the COUNTY any easements reasonably necessary to connect the Wastewater Treatment Facilities to the Wastewater Transmission Facilities and collection facilities located on the Property in order to direct

flows from the Property to the Wastewater Treatment Facilities and effluent disposal facilities. Said conveyances shall be free and clear of all encumbrances whatsoever. Said parcels shall be the sites of the Water Treatment Facilities and Wastewater Treatment Facilities.

SECTION 6. RATES, FEES, AND CHARGES. As a condition to the provision of Water and Wastewater Service Capacities, OWNER agrees to pay certain rates, fees and charges as hereinafter set forth in this Section 6, subject to offset for any credits earned by OWNER, as set forth in Subsection 6.1 herein.

6.1. Water and Wastewater Capital Charges; Credits Against Wastewater Capital Charges.

(1) To induce the COUNTY to provide Water Service Capacity and Wastewater Service Capacity to OWNER for use on the OWNER's Property, OWNER agrees to: (1) construct and dedicate all Facilities pursuant to Section 4, herein; and (2) grant the deeds and easements in accordance with the terms and provisions of Section 5, herein. In exchange therefor, OWNER shall be entitled to ERC credits for Water Service Capacity and Wastewater Service Capacity not to exceed the ERC's necessary to Service the number of units actually constructed on the Property, which is estimated to be ultimately eleven hundred (1,100) ERCs. All fees, costs and charges other than the Water Capital Charges and Wastewater Capital Charges shall be paid by OWNER and/or customers of the system, as applicable.

6.2. Rates and Charges. Rates and other charges to OWNER shall be those set forth from time to time in the COUNTY's Rate Resolutions and Ordinances. The COUNTY may establish, amend or revise, from time to time in the future, and enforce rules and regulations covering Water and Wastewater Service Capacity to OWNER's Property. Such rules and regulations so established by the COUNTY shall at all times be reasonable and subject to such regulation as may be applicable. Any initial or future lower or increased rates, rate schedules, capacity charges or other fees and charges, and rules and regulations established, amended or revised and enforced by the COUNTY from time to time in the future, shall be binding upon OWNER, upon any person or other entity holding by, through or under OWNER, and upon any user or customer of the Water and Wastewater Service Capacity provided to the OWNER's Property.

SECTION 7. ALLOCATION AND PROVISION OF WATER AND WASTEWATER SERVICE CAPACITY.

7.1. Allocation. Subject to OWNER's compliance with the terms and conditions of this Agreement and applicable COUNTY rules and payment of applicable Water and Wastewater Capital Charges, the COUNTY hereby agrees to allocate and reserve five hundred fifty (550) ERCs of Water Service Capacity and five hundred fifty (550) ERCs of Wastewater Service Capacity to OWNER for use by OWNER with its

Improvements on the Property in each of the two (2) phases for a total of eleven hundred (1,100) ERCs of Water and Wastewater Service Capacities. The Water and Wastewater Service Capacity reserved pursuant to this Agreement shall be made available for use by OWNER, its successors and assigns in accordance with applicable COUNTY rules.

7.2. Provision of Water and Wastewater Service Capacity. Upon the completed conveyance of easements referenced herein, and construction of applicable Water Facilities and Wastewater Facilities, payment of applicable rates, fees, and charges, and the physical connection of a given Customer Installation to the Marion County Water System and Marion County Wastewater System, the COUNTY agrees to continuously provide Water and Wastewater Service Capacity to OWNER in accordance with the terms and conditions of this Agreement and its rules. Notwithstanding the above, the COUNTY does not guarantee or warrant any special service, pressure, quality or other facility other than what is required to fulfill a duty of reasonable care to the customers to whom it provides such Water and Wastewater Service Capacities.

SECTION 8. REMAINING WATER AND WASTEWATER SERVICE CAPACITY.

The COUNTY shall have the right to allocate any remaining Wastewater Service Capacity not allocated pursuant to this Agreement to other users as it determines to be in the public interest. Notwithstanding subsection 6.1 hereof, the COUNTY may otherwise allocate Wastewater Service Capacity in the Wastewater Treatment Facilities to other users as it determines to be in the public interest and shall not be deemed in default of this Agreement so long as the COUNTY determines that it can provide Wastewater Service Capacity to OWNER in the volume demanded by it not in excess of its allocation no later than ninety (90) days after receipt of written demand from OWNER. In addition, COUNTY shall have the unequivocal right to expand the Facilities.

SECTION 9. INCORPORATION OF COUNTY POLICIES. This Agreement shall

be read in conjunction with and be subject to all existing and future federal, state, local, and COUNTY laws, rules, and policies applicable to Water and Wastewater Utilities in any manner or form, including without limitation the Marion County Land Development Regulations Code, the Marion County Comprehensive Plan, and other applicable provisions of the Marion County Code.

SECTION 10. COVENANT NOT TO ENGAGE IN COUNTY BUSINESS. OWNER,

as a further consideration for this Agreement, agrees that it shall not (the words "shall not" being used in a mandatory definition) engage in the business of providing Water and Wastewater Service Capacity to the OWNER's Property during the period of time the COUNTY, its successors and assigns, provide Water and Wastewater Service Capacities to the OWNER's Property, it being the intention of the parties hereto that the foregoing provision shall be a covenant running with the land and under said provision and also under other provisions of this Agreement the COUNTY shall have the sole and exclusive right and privilege to provide Water and Wastewater Service Capacities to the OWNER's Property and to the occupants of each residence, building or unit constructed thereon.

Water and
MP 20P
BTK
[Signature]

Water and
MP 20P
BTK
[Signature]

[Signature]
BTK
MP 20P

SECTION 11. MISCELLANEOUS.

11.1. Oversizing. As a condition precedent to allowing OWNER to proceed with the design and construction of the on-site Water and Wastewater Facilities (i.e. excluding treatment and disposal systems), the COUNTY may require OWNER to design, obtain all necessary permits and approvals for, and construct the Water Facilities or Wastewater Facilities with capacity in an amount greater than the amount of capacity necessary to serve only OWNER's Property. In this event, the following shall apply:

(1) With respect to the oversizing of any such Facilities, the COUNTY shall give written notice to OWNER within thirty (30) days after the approval of this Agreement by the COUNTY Commission, with respective capacities in an amount greater than the amount of capacities necessary to serve only OWNER's Property.

(2) The design, permitting, and construction of any oversized Facilities shall be subject to the COUNTY's review, inspection, approval, and acceptance provided in Section 4.

(3) In the event the COUNTY requires oversizing, the COUNTY shall reimburse OWNER in the manner hereinafter set forth for all approved "oversizing incremental costs" which is the difference between:

(a) the construction costs actually incurred by OWNER for the oversized Facilities, and

(b) the construction costs which would have been incurred for the Transmission Facilities if the same were designed and constructed with only enough capacity to serve OWNER's property. The oversizing incremental costs shall be determined by the COUNTY and may be based on alternative bids solicited by OWNER.

(4) All reimbursements to be paid hereunder shall be non-interest bearing and are considered as refundable advances which will be due and payable if sufficient funds are collected by the COUNTY from other developers utilizing said Facilities, as more particularly set forth in and subject to the conditions of the COUNTY's Rules and Regulations.

11.2. Performance and Maintenance Bonds; Letters of Credit.

(1) Upon acceptance by the COUNTY of any phase of Water Facilities or Wastewater Facilities, OWNER shall simultaneously with the COUNTY's

(2) acceptance thereof, provide a one year performance bond made payable to the COUNTY in the amount of the construction costs of that said phase.

(3) Upon subsequent acceptance by the COUNTY of any other portion or phase of the said Facilities, OWNER shall simultaneously with the COUNTY's acceptance thereof of each portion or phase:

(a) provide a one year performance bond made payable to the COUNTY in the amount of one hundred percent (100%) of the value of that particular portion or phase of the said Facilities in order to guarantee that particular portion or phase has been constructed in accordance with the terms and conditions of this Agreement, and

(b) provide a one year maintenance bond made payable to the COUNTY in the amount of ten percent (10%) of the value of that particular portion or phase of the said Facilities in order to guarantee the correction of any defects in design, workmanship or materials of that particular portion or phase.

11.3. Exclusive Provider. COUNTY shall be the exclusive provider of Water and Wastewater Service upon completion of the Water Facilities and Wastewater Facilities.

SECTION 12. METER INSTALLATION. Upon written notification by the OWNER or its designated agent, the COUNTY shall install a water meter or water meters at the location or locations specified by the OWNER or their said agent within ten (10) business days for up to fifty (50) meters over any thirty (30) day period. The size and type of water meters installed by the COUNTY shall be in accordance with the standard uniform practice of the COUNTY. In the event of dispute as to the application of such standard uniform practice, the COUNTY shall have the right to install the size and type meter which the COUNTY designates. The COUNTY shall not be obligated to install or connect any water meter for which the meter and meter installation fees have not been paid.

SECTION 13. DISCLAIMERS LIMITATIONS ON LIABILITY.

13.1. Status. THE PARTIES DEEM EACH OTHER TO BE INDEPENDENT CONTRACTORS, AND NOT AGENTS OF THE OTHER.

13.2. Disclaimer of Third Party Beneficiaries. THIS AGREEMENT IS SOLELY FOR THE BENEFIT OF AND SHALL BE BINDING UPON THE FORMAL PARTIES HERETO AND THEIR RESPECTIVE AUTHORIZED SUCCESSORS AND ASSIGNS, AND NO RIGHT OR CAUSE OF ACTION SHALL ACCRUE UPON OR BY REASON HEREOF, TO OR FOR THE BENEFIT OF ANY THIRD PARTY NOT A PARTY TO THIS AGREEMENT OR AN AUTHORIZED SUCCESSOR OR ASSIGNEE THEREOF.

13.3. Disclaimer of Security. NOTWITHSTANDING ANY OTHER PROVISION OF THIS AGREEMENT, OWNER EXPRESSLY ACKNOWLEDGES (1) THAT

IT HAS NO PLEDGE OF OR LIEN UPON ANY REAL PROPERTY (INCLUDING, SPECIFICALLY, THE COUNTY'S SYSTEM), ANY PERSONAL PROPERTY, OR ANY EXISTING OR FUTURE REVENUE SOURCE OF THE COUNTY (INCLUDING SPECIFICALLY, ANY REVENUES OR RATES, FEES, OR CHARGES COLLECTED BY THE COUNTY IN CONNECTION WITH THE COUNTY'S SYSTEM) AS SECURITY FOR ANY AMOUNTS OF MONEY PAYABLE BY THE COUNTY UNDER THIS AGREEMENT; AND (2) THAT ITS RIGHTS TO ANY PAYMENTS OR CREDITS UNDER THIS AGREEMENT ARE SUBORDINATE TO THE RIGHTS OF ALL HOLDERS OF ANY STOCKS, BONDS, OR NOTES OF THE COUNTY, WHETHER CURRENTLY OUTSTANDING OR HEREAFTER ISSUED.

SECTION 14. NOTICE; PROPER FORM. Any notices required or allowed to be delivered hereunder shall be in writing and be deemed to be delivered when (1) hand delivered to the official hereinafter designated, or (2) upon receipt of such notice when deposited in the United States mail, postage prepaid, certified mail, return receipt requested, addressed to a party at the address set forth opposite the party's name below, or at such other address as the party shall have specified by written notice to the other parties delivered in accordance herewith:

COUNTY: Marion County
601 S.E. 25th Avenue
Ocala, FL 34471-2690
Attention: COUNTY Administrator

with a copy to: Thomas A. Cloud, Esq.
Gray, Harris & Robinson, P.A.
201 East Pine Street, Suite 1200
Orlando, Florida 32801

OWNER: Siemens Ocala Corp.
4800 North Federal Highway, Suite 202-E
Boca Raton, Florida 33431
Attention: Richard Siemens

SECTION 15. NOTICES; DEFAULT. Each of the parties hereto shall give the other party written notice of any defaults hereunder and shall allow the defaulting party (1) thirty (30) days from the date of its receipt of such notice within which to cure any such defaults not related to the payment of money, or to commence and thereafter diligently pursue to completion good faith efforts to effect such cure and to thereafter notify the other party of the actual cure of any such defaults, or (2) ten (10) days from the date of its receipt of such notice within which to cure any such defaults related to the payment of money.

FILE: 97103547
OR BOOK/PAGE: 2444/856

SECTION 16. ASSIGNMENTS.

16.1. Assignments by OWNER. Except as expressly provided herein, OWNER agrees not to assign or transfer all or any portion of this Agreement. The allocation of Water and Wastewater Service Capacity granted to OWNER may be assigned, transferred, leased, encumbered or disposed of if and only if:

(1) OWNER has obtained the prior written consent of the COUNTY to such an assignment, sale or disposition, which consent shall not be unreasonably withheld; or

(2) The assignment is in direct connection with a bonafide sale of the OWNER's Property or a portion thereof to which the Water and Wastewater Service Capacity reserve relates, and the COUNTY is notified in writing of such assignment; and

(3) The assignee pays all of the COUNTY's legal and administrative costs incurred in connection with such Assignment and assumes all of the duties and obligations of the assignor under this Agreement.

16.2. Assignments by COUNTY. The COUNTY shall have the right to assign or transfer this Agreement or the rights and responsibilities contained herein to any properly authorized commission, authority, or public firm, or entity without consent of OWNER.

16.3. Notice of Transfer of OWNER'S Property. OWNER agrees to provide proper written notice to the COUNTY of the actual date of the legal transfer of Water and Wastewater Service Capacity from OWNER to any third party. OWNER shall remain responsible for all costs and expenses including utility bills, which arise as a result of OWNER's failure to notify or improper notification to the COUNTY.

16.4. Binding Agreement or Successors. This Agreement shall be binding upon and shall inure to the benefit of OWNER, the COUNTY and their respective successors and assigns.

SECTION 17. RECORDATION. The parties hereto agree that an executed copy of this Agreement and Exhibits attached hereto shall be recorded in the Public Records of Marion County, Florida at the expense of OWNER.

SECTION 18. APPLICABLE LAW. This Agreement and the provisions contained herein shall be construed, controlled, and interpreted according to the laws of the State of Florida.

FILE: 97103547
OR BOOK/PAGE: 2444/857

SECTION 19. SURVIVAL OF COVENANTS. The rights, privileges, obligations and covenants of OWNER and the COUNTY shall survive the completion of the work of OWNER with respect to any phase and to the OWNER's Property as a whole.

SECTION 20. SEVERABILITY. If any part of this Agreement is found invalid or unenforceable by any court, such invalidity or unenforceability shall not affect the other parts of this Agreement if the rights and obligations of the parties contained therein are not materially prejudiced, and if the intentions of the parties can continue to be effected. To that end, this Agreement is declared severable.

SECTION 21. RECOVERY OF COSTS AND FEES. In the event the COUNTY or OWNER is required to enforce this Agreement by court proceedings or otherwise, then the prevailing party shall be entitled to recover from the other party all costs incurred, including reasonable attorneys' fees, whether incurred prior to, during or subsequent to such court proceedings or on appeal.

SECTION 22. AUTHORITY TO EXECUTE AGREEMENT. The signature by any person to this Agreement shall be deemed a personal warranty by that person that he has the full power and authority to bind any corporation, partnership, or any other business entity for which he purports to act hereunder.

SECTION 23. TIME OF THE ESSENCE. Time is hereby declared of the essence to the lawful performance of the duties and obligations contained in this Agreement.

SECTION 24. ENTIRE AGREEMENT. This instrument and its exhibits constitute the entire Agreement between the parties and supersedes all previous discussions, understandings, and agreements between the parties relating to the subject matter of this Agreement.

SECTION 25. AMENDMENTS. Amendments to and waivers of the provisions contained in this Agreement may be made only by the parties in writing by formal amendment.

IN WITNESS WHEREOF, the parties hereto have hereunder executed this Agreement on the day and year first above written.

Signed, sealed and delivered
in the presence of:

(x) Madeline Williamson

Name: Madeline Williamson

(x) Miriam Pauley

Name: Miriam Pauley

MARION COUNTY, FLORIDA

By: Steve F. Henning

Steve F. Henning, Chairman
Board of COUNTY Commissioners

Attest: Thomas P. Klinker
Thomas P. Klinker, Clerk

FILE: 97103547

OR BOOK/PAGE: 2444/858

STATE OF FLORIDA
COUNTY OF MARION

The foregoing instrument was acknowledged before me this 1st day of OCTOBER, 1996, by **Steve F. Henning**, Chairman of The Board of County Commissioners of Marion County, Florida, on behalf of MARION COUNTY. He is personally known to me or has produced n/a as identification and ~~did~~(did not) take an oath.

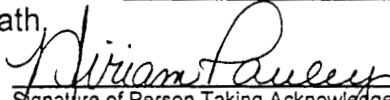

Signature of Person Taking Acknowledgement

Miriam Pauley
Name of Acknowledger Typed, Printed or Stamped

Notary Public
Title or Rank

Commission #CC319909
Serial Number, if any.
Expires: October 29, 1997



MIRIAM PAULEY
MY COMMISSION # CC319909 EXPIRES
October 29, 1997
EDWARDS TITLE TRUST & INSURANCE, INC

FOR THE USE AND RELIANCE
OF MARION COUNTY ONLY.
APPROVED AS TO FORM.

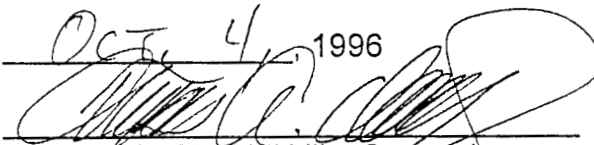
Oct 4, 1996

Thomas A. Cloud, Utility Counsel

FILE: 97103547
OR BOOK/PAGE: 2444/859

17 of 47

Signed, sealed and delivered
in the presence of:

OWNER:

x: Diane C. Wilson

[Signature]

x: Jessie D. Cronley

PLATO KIRBY, JR., an individual

STATE OF FLORIDA
COUNTY OF Indian River

The foregoing instrument was acknowledged before me this 24th day of Sept, 1996 by PLATO KIRBY, JR. He is personally known to me or has produced as identification and did (did not) take an oath.

[Signature]

Signature of Person Taking Acknowledgment

SUSANNE PETRUZZELLO

Name of Acknowledger Typed, Printed or Stamped

[Signature]
Title or Rank

Serial Number, if any.



"OFFICIAL SEAL"
Susanne Petruzzello
My Commission Expires 11/12/96
Commission #CC 241576

FILE: 97103547
OR BOOK/PAGE: 2444/860

Signed, sealed and delivered
in the presence of:

OWNER:

x: Diane C. Wilson
x: Jeanette Cronberg

Beneta J Kirby
BENETA KIRBY, an individual

STATE OF FLORIDA
COUNTY OF Indian River

The foregoing instrument was acknowledged before me this 24th day of Sept, 1996 by BENETA KIRBY. She is personally known to me or has produced as identification and did (did not) take an oath.

Susanne Petruzzello
Signature of Person Taking Acknowledgment

SUSANNE PETRUZZELLO
Name of Acknowledger Typed, Printed or Stamped

AVP
Title or Rank

Serial Number, if any.



"OFFICIAL SEAL"
Susanne Petruzzello
My Commission Expires 11/12/96
Commission #CC 241576

FILE: 97103547
OR BOOK/PAGE: 2444/861

Signed, sealed and delivered
in the presence of:

OWNER:

x: M. Dean Perry, Jr.
M. Dean Perry, Jr.
x: Hilda P. Surrency
Hilda P. Surrency

M.D. Perry
M.D. PERRY, an individual

STATE OF FLORIDA
COUNTY OF MARION

The foregoing instrument was acknowledged before me this 23rd day of September, 1996, by M.D. PERRY. He is personally known to me or has produced as identification and ~~did~~ (did not) take an oath.

Hilda P. Surrency
Signature of Person Taking Acknowledgment

Name of Acknowledger Typed, Printed or Stamped

Title or Rank

Serial Number, if any.

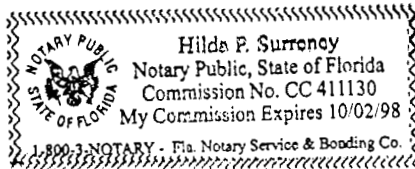

FILE: 97103547
OR BOOK/PAGE: 2444/862

20 of 47

Signed, sealed and delivered
in the presence of:

OWNER:

x: M. Dean Perry, Jr.
M. Dean Perry, Jr.
x: Hilda P. Surrency
Hilda P. Surrency

Frances O. Perry
FRANCES O. PERRY, an individual

STATE OF FLORIDA
COUNTY OF MARION

The foregoing instrument was acknowledged before me this 23rd day of September, 1996, by FRANCES O. PERRY. She is personally known to me or has produced _____ as identification and ~~did~~ (did not) take an oath.

Hilda P. Surrency
Signature of Person Taking Acknowledgment

Name of Acknowledger Typed, Printed or Stamped

Title or Rank

Serial Number, if any.

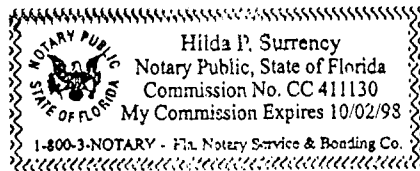

FILE: 97103547
OR BOOK/PAGE: 2444/863

Signed, sealed and delivered
in the presence of:

(x) Roy Christie

Name: Roy CHRISTIE

(x) R. Siemens

Name: Rob Siemens

SIEMENS OCALA CORP., a Florida corporation

By: Richard Siemens
Richard Siemens
President

(CORPORATE SEAL)

STATE OF Florida

COUNTY OF Palm Beach

The foregoing instrument was acknowledged before me this 25 day of September, 1996 by Richard Siemens, President of SIEMENS OCALA CORP., a Florida corporation. He is personally known to me or has produced _____ as identification and did (did not) take an oath.

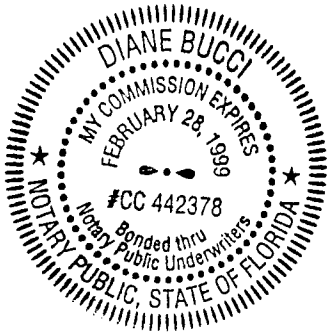

ayurko\marionlw-util3.agr

Diane Bucci
Signature of Person Taking Acknowledgement

DIANE BUCCI
Name of Acknowledger Typed, Printed or Stamped

Title or Rank

Serial Number, if any.

FILE: 97103547
OR BOOK/PAGE: 2444/864

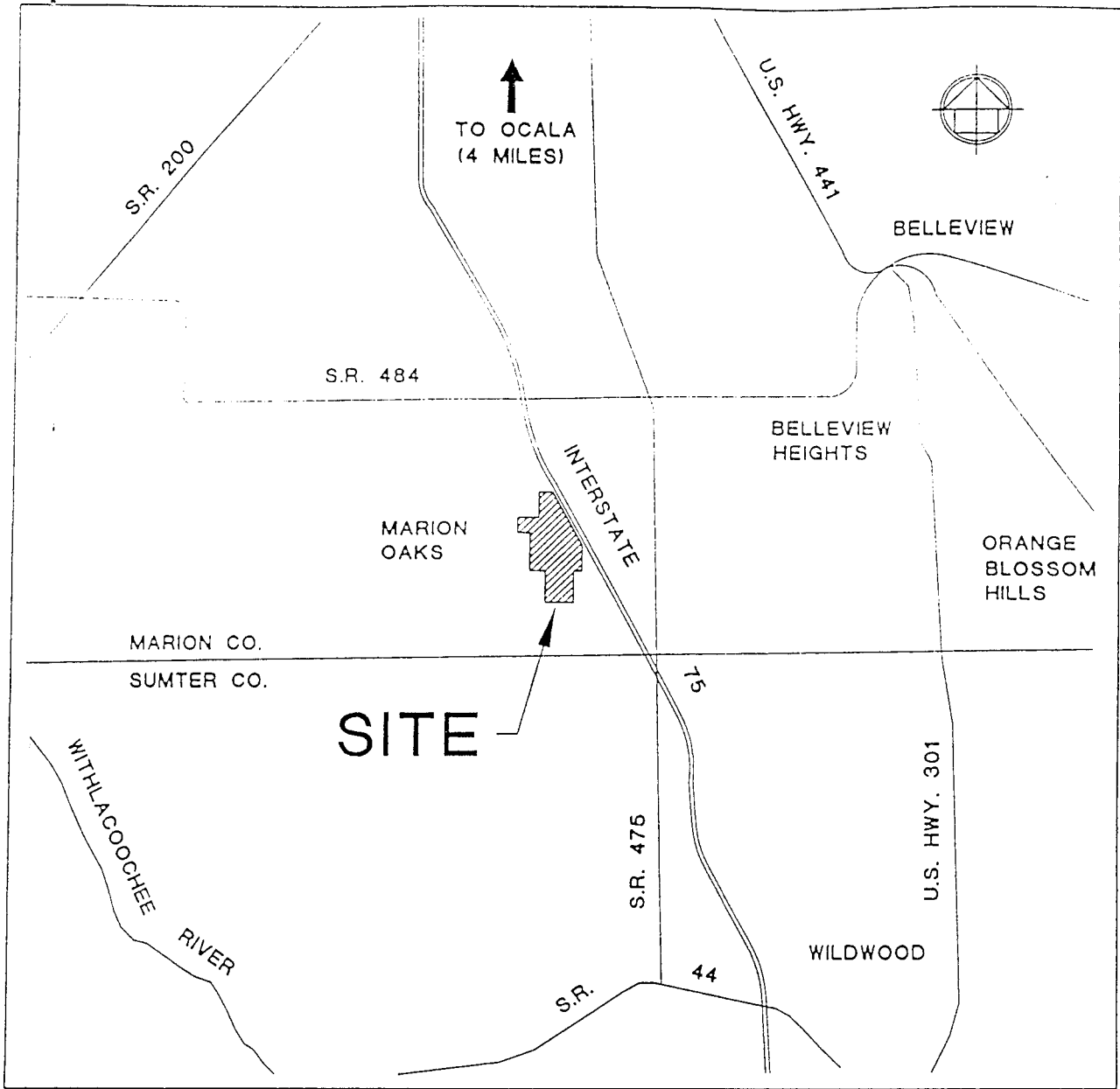

SITE

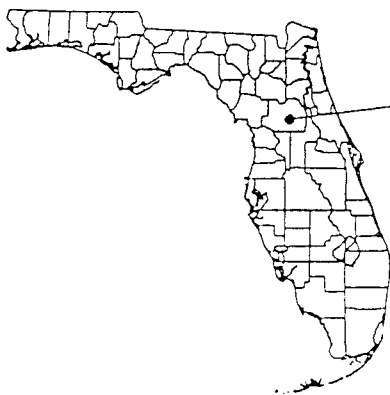

MARION COUNTY

SECTION : 19, 24 & 30
 TOWNSHIP : 17 SOUTH
 RANGE : 21 & 22 EAST

23 of 47

FILE: 97103547
 OR BOOK/PAGE: 2444/865

VICINITY MAP



COMPOSITE
 EXHIBIT "A"

Page 1 of 4

S.R. 475-A

41201

44639

44639-001

13 18
24 19

R-1
7-8830-8

R-4
(C-1)
44645-002

M-1
(C-2)
41338

S.W. 20th AVENUE
I-75

44645

MARION OAKS
8003-0000-00

A-1
44646

44651

R-4
(C-1)

SITE

44645-001

R-4
(C-1)

44630

24 19
25 30

44637-001

44842

R-4
(C-1)
44843

FILE: 97103547
GR BOOK/PAGE: 2444/866

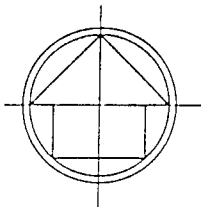

SCALE: 1"=1500'

LOCATION MAP



COMPOSITE
EXHIBIT "A"

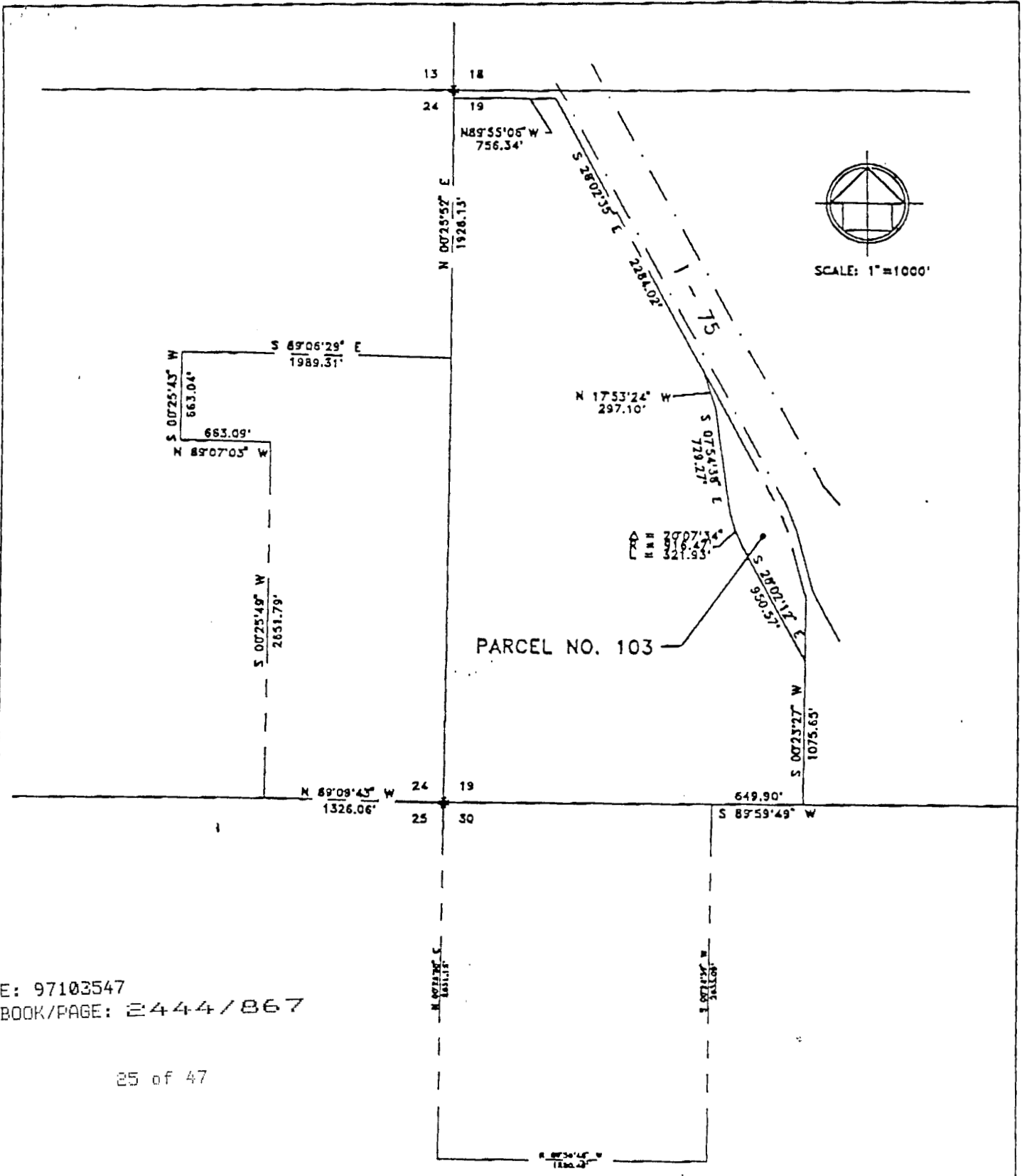

FILE: 97103547
 OR BOOK/PAGE: 2444/867

25 of 47

BOUNDARY SKETCH

COMPOSITE
 EXHIBIT "A"



LEGAL DESCRIPTION:

The South 1/2 of the SE 1/4 of the NE 1/4 and SE 1/2 of the SW 1/4 of the NE 1/4 and the East 1/2 of the SE 1/4 of Section 24, Township 17 South, Range 21 East, and; that portion of the West 1/2 of Section 19, Township 17 South, Range 22 East, lying westerly of the interstate highway 1-75 right-of-way, the west one-half of the northwest one-quarter, and the west one-half of the East one-half of the northwest one-quarter of Section 30, Township 17 South, Range 22 East, less and except the following described parcel:

Parcel No. 103

That part of:

The NW 1/4, lying West of State Road 93 (I-75); AND the SW 1/4, lying West of State Road 93 (I-75), LESS the West 1/2 of the NW 1/4 of the SW 1/4, ALL LYING and being in Section 19, Township 17 South, Range 22 East, Marion County, Florida,

described as follows:

Commence at the Southeast corner of the SW 1/4 of Section 19, Township 17 South, Range 22 East, Marion County, Florida; thence run North 0°07'21" East along the East line of said SW 1/4 a distance of 1075.65 feet for the POINT OF BEGINNING; thence, departing said East line, North 28°19'28" West 950.57 feet to the beginning of a curve concave Northeasterly, having a radius of 916.47 feet and a chord bearing of North 10°15'41" West; thence Northeasterly along the arc of said curb through a central angle of 20°07'34" a distance of 321.93 feet to the end of a said curve; thence North 08°11'54" West 729.27 feet; thence North 18°10'40" West 297.12 feet to a point on the Westerly right-of-way line of a 60-foot county road; thence South 28°19'28" East along said Westerly right-of-way line 1164.11 feet; thence, continuing along said Westerly right-of-way line South 21°12'29" East 198.66 feet; thence South 15°01'33" East 458.16 feet; thence South 28°19'28" East 12.70 feet to a point on the East line of the NE 1/4 of the SW 1/4 of said Section 19; thence, departing said Westerly county right-of-way line, South 0°06'06" West along said East line 232.48 feet to the Northeast corner of the SE 1/4 of the SW 1/4 of said Section 19; thence South 00°07'21" West along the East line of the SE 1/4 of the SW 1/4 of said Section 19 a distance of 248.92 feet to the Point of Beginning.

Said Land being located in Marion County, Florida;

FILE: 97103547
OR BOOK/PAGE: 2444 / 868

CONTAINING 459.7 acres, more or less

26 of 47

LEGAL DESCRIPTION

SIEMENS
 GROUP

COMPOSITE
EXHIBIT "A"

Page 4 of 4

OCALA MEADOWS

CCL PROJECT NO. 3574

September 5, 1996

WATER AND WASTEWATER PLANT SPECIFICATIONS

| | |
|---|----------------------------------|
| Number of units served by initial phases | 1,100 Du |
| Water requirements based on 350 GPD/Unit | 385,000 GPD |
| Wastewater requirements based on 300 GPD/Unit | 330,000 GPD |
| Project will be built in two (2) phases | |
| Land requirements | |
| Water Plant | 2 AC |
| Wastewater Plant | 10 AC |
| Fire flow requirements | 2,000 GPM/2 HRS |
| Storage capacity (both phases) | 250,000 GALLONS |
| WATER PLANT (PHASE 1) | |
| Plant Capacity - Phase 1 | 200,000 GPD |
| Wells - 2 Each | 325 GPM PUMP CAPACITY EACH |
| Treatment - Aerator/Chlorine | |
| Hydropneumatic tanks | 2 - 20,000 GALLONS |
| High service pumps | TWO - 700 GPM ONE - 1,400 GPM |
| Fire Pump | ONE - 2,000 GPM |
| Ground storage | 250,000 GALLONS |
| Necessary site work and piping etc. | |
| Ultimate Plant Capacity - Phase 2 | 400,000 GPD |

WASTEWATER PLANT

| | |
|--|-----------------|
| Plant capacity - Phase 1 | 200,000 GPD |
| Extended aeration plant w/filters to meet Class I reliability surge tank | |
| Aeration tank | 200,000 GALLONS |
| Sludge holding tank | 2,000 Sq.Ft. |
| Clarifier | 35,000 GALLONS |
| Chlorine contact | 5,200 GALLONS |
| Filters (loading rate 2 GPM/Sq.Ft. @ADF) | 70 Sq.Ft. |

Effluent storage will be lined lake with 5 days capacity (1,750,000 Gallons)

Effluent will be disposed of by spray irrigation to an on-site golf course

Necessary site piping, etc.

| | |
|-----------------------------------|-------------|
| Ultimate Plant Capacity - Phase 2 | 350,000 GPD |
|-----------------------------------|-------------|

FILE: 97103547
OR BOOK/PAGE: 2444/870

28 of 47

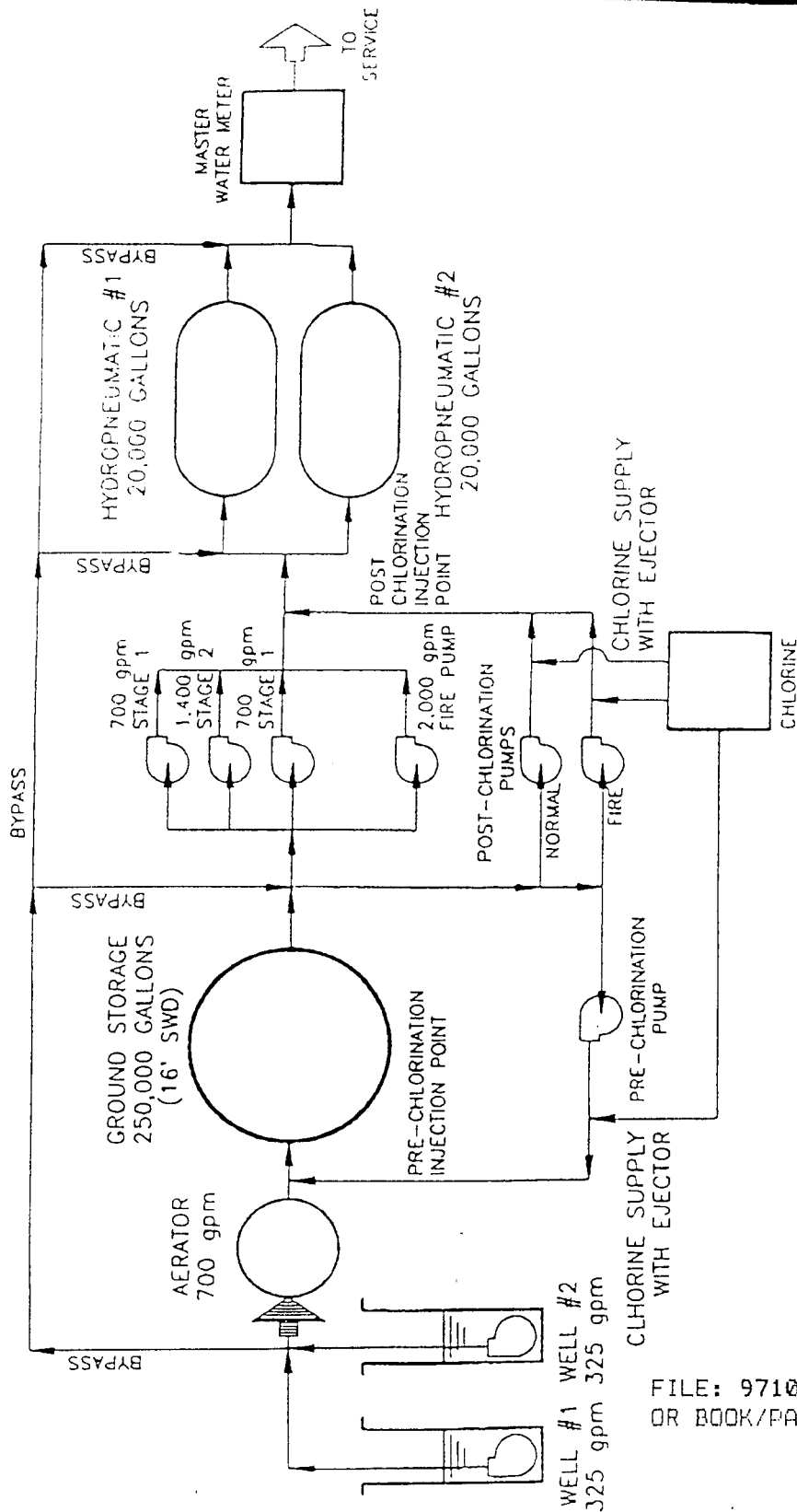

Ocala Meadows
WATER TREATMENT PLANT
FLOW DIAGRAM

| | | | |
|------------------|---------------|-------------------------|-----------------|
| DESIGNED BY: PRB | DATE: 9/11/96 | PROJECT NO: 205,000 GPD | SCALE: 1" = 10' |
| CHECKED BY: ARH | DATE: 9/11/96 | PROJECT NO: WTP 200 | SCALE: 1" = 10' |
| DATE: 9/11/96 | DATE: 9/11/96 | PROJECT NO: 205,000 GPD | SCALE: 1" = 10' |
| DATE: 9/11/96 | DATE: 9/11/96 | PROJECT NO: 205,000 GPD | SCALE: 1" = 10' |

FILE: 97103547
OR BOOK/PAGE: 2444 / 871

29 of 47

WATER TREATMENT PLANT

EXHIBIT "C"



WATER TREATMENT PLANT

EXHIBIT "C"

Page 2 of 4

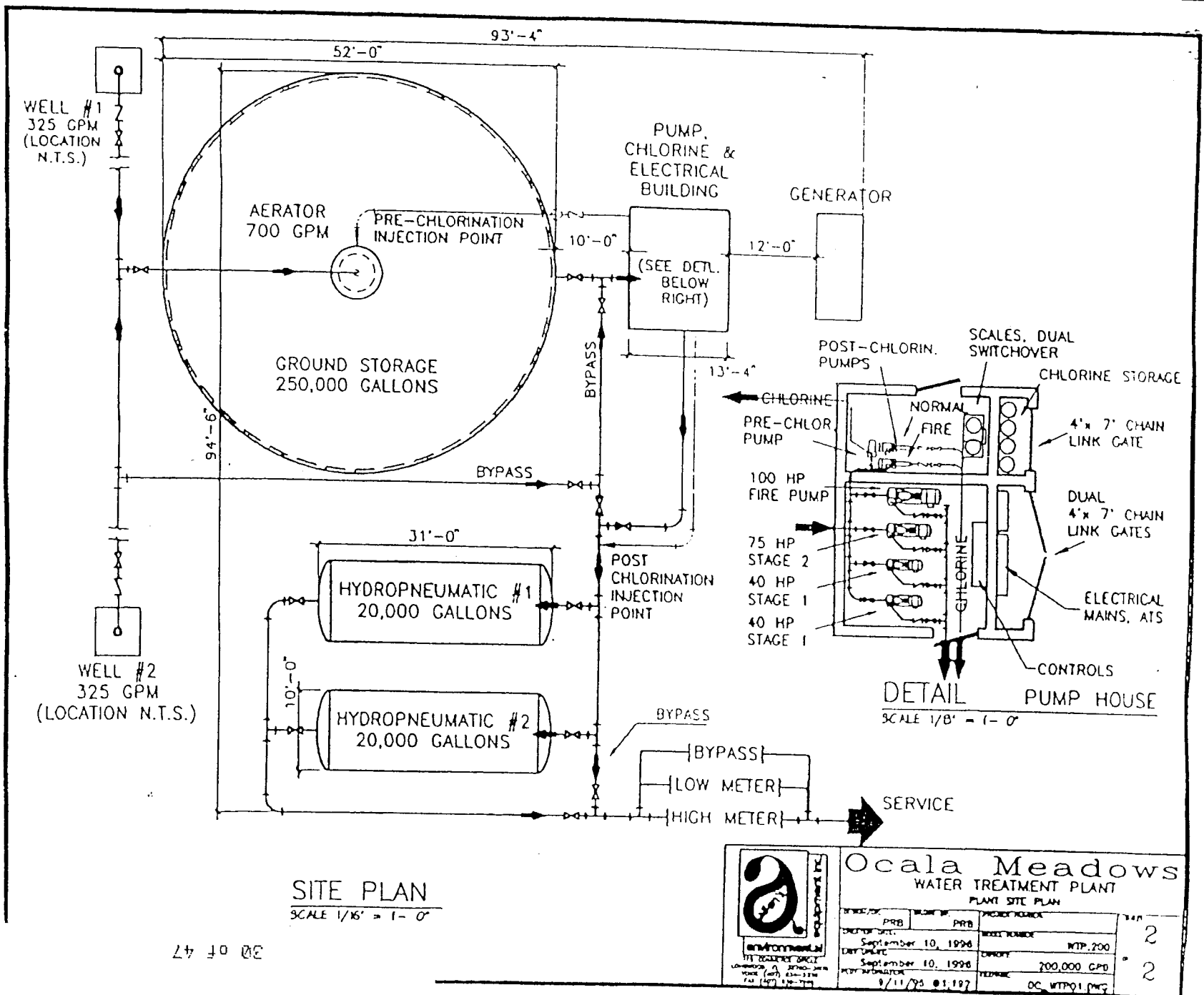

SITE PLAN

SCALE 1/16" = 1'-0"

30 of 47



| | | | |
|--|-----|--------------------|----------------|
| Ocala Meadows WATER TREATMENT PLANT | | | |
| PLANT SITE PLAN | | | |
| DESIGN NO. | PRB | DATE OF PRB | PROJECT NUMBER |
| DESIGNED BY | PRB | September 10, 1998 | WTP-200 |
| CHECKED BY | PRB | September 10, 1998 | 200,000 GPD |
| DATE | PRB | 9/11/98 | DC WTP01 DWG |
| SCALE | | 1/16" = 1'-0" | 2 |
| SHEET NUMBER | | 2 | 2 |

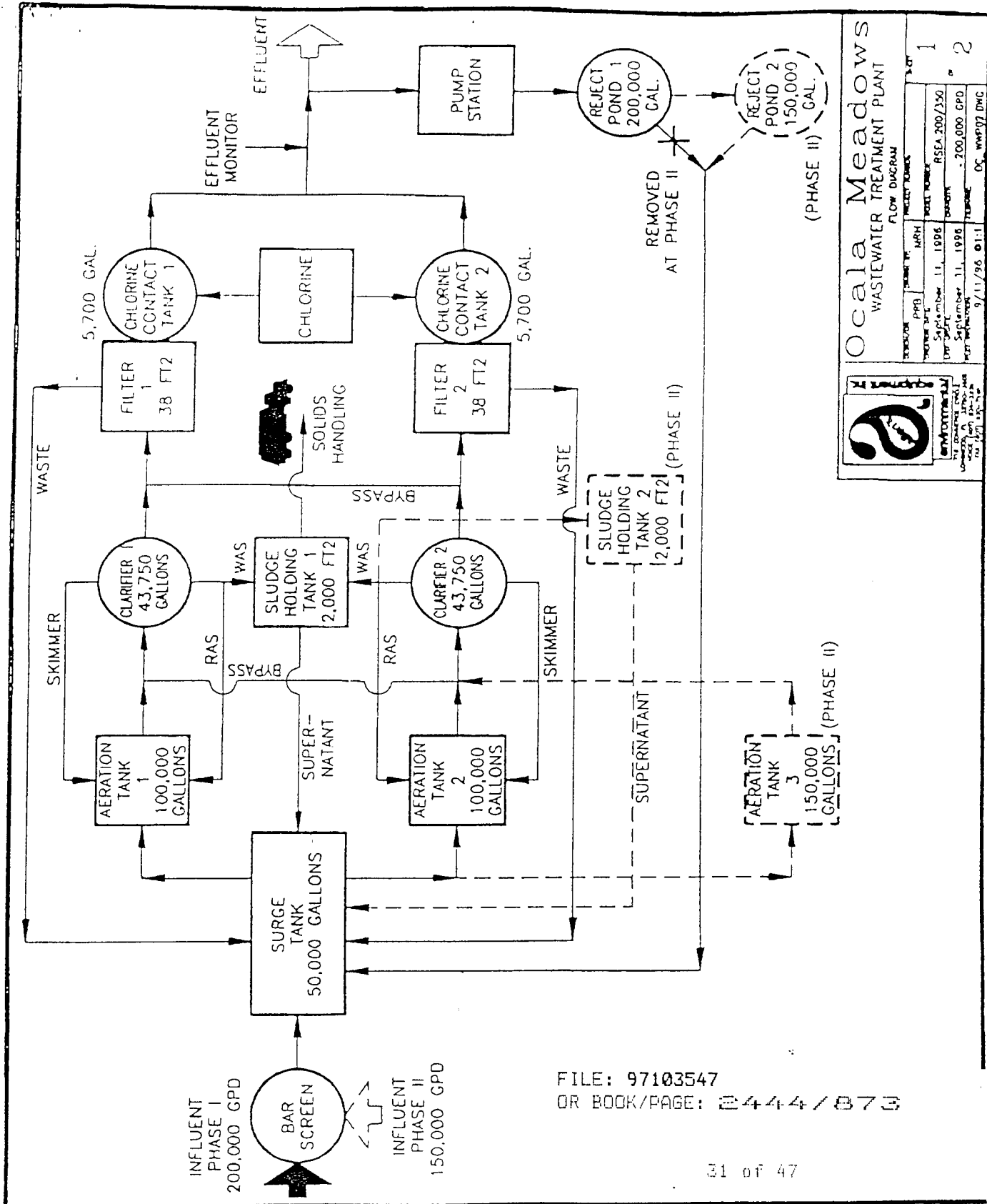

Ocala Meadows
WASTEWATER TREATMENT PLANT
FLOW DIAGRAM

| | | | |
|-------------|----------|----------------|-----|
| DESIGNED BY | DATE | PROJECT NUMBER | NO. |
| ENGINEER | 11, 1996 | RSEA.200/350 | 1 |
| DATE | 11, 1996 | PROJECT | NO. |
| 11, 1996 | 11, 1996 | 200,000 GPD | 2 |
| DATE | 9/11/96 | REVISION | NO. |
| 11, 1996 | 9/11/96 | DC WWP02.DWG | |

Equipment
BY COMPANY
11, 1996
11, 1996
11, 1996

FILE: 97103547
OR BOOK/PAGE: 2444/873

WASTE WATER TREATMENT PLANT



EXHIBIT "C"

WASTE WATER TREATMENT PLANT

EXHIBIT "C"

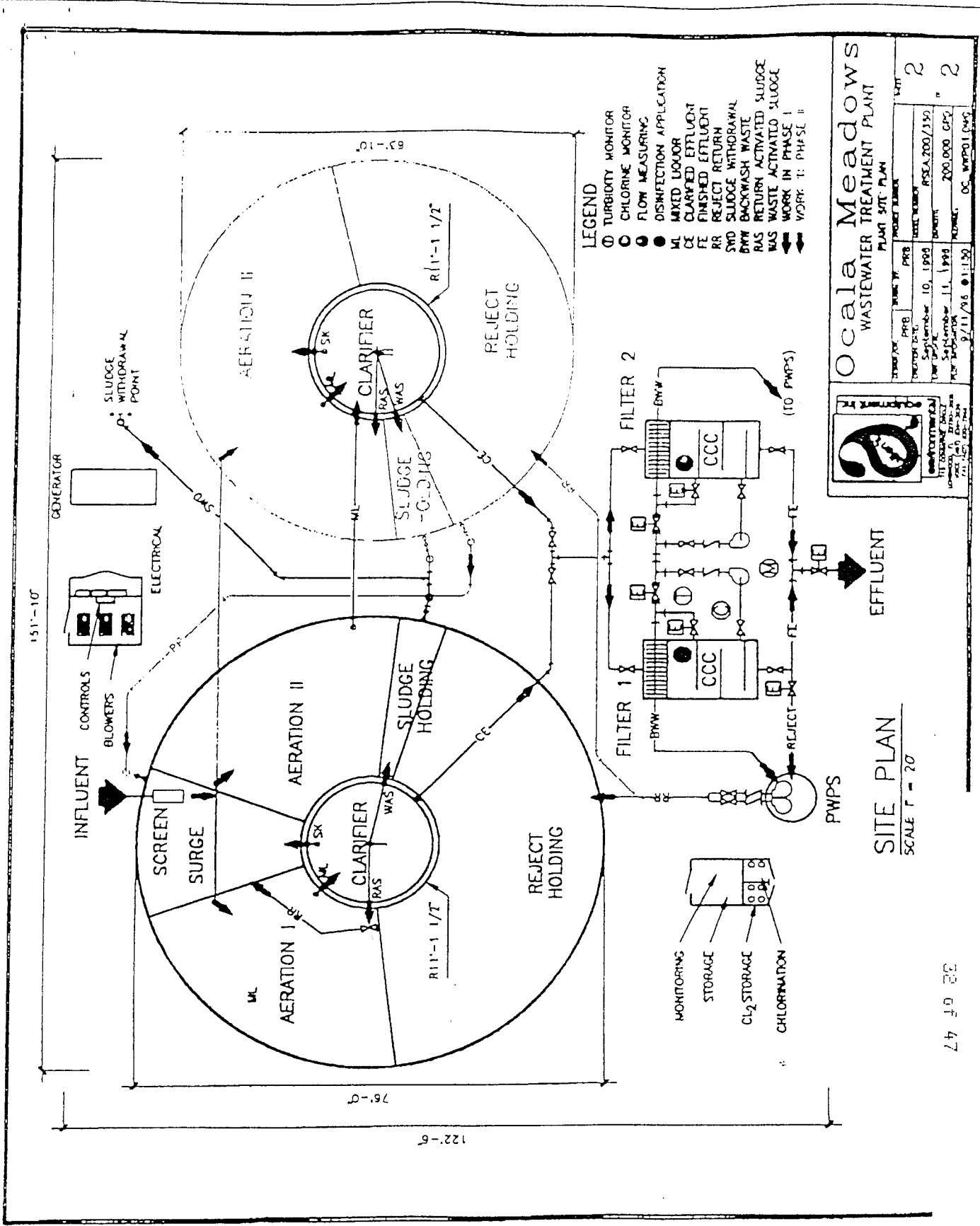

Ocala Meadows
WASTEWATER TREATMENT PLANT

PLANT SITE PLAN

| | |
|----------------|--------------------|
| PROJECT NUMBER | 2 |
| DATE | 2 |
| DESIGNED BY | PER |
| DESIGNED DATE | 10, 1998 |
| PROJECT NUMBER | 95EA700/130 |
| DATE | September 11, 1998 |
| PROJECT | 200,000 GPD |
| DATE | 9/11/98 @ 11:30 |
| PROJECT | DC APPROVALS |

SIEMENS

SIEMENS WATER TECHNOLOGIES
10000 W. BROADWAY
DENVER, CO 80231
TEL: 303.733.1000
FAX: 303.733.1001

SITE PLAN
SCALE 1" = 20'

EXHIBIT "E"

**EASEMENT AND RECLAIMED
WATER DELIVERY AGREEMENT**

This Agreement is made and entered into this 1st day of OCTOBER, 1996, by MARION COUNTY, a political subdivision of the State of Florida (hereafter "Grantee"), and S. PLATO KIRBY, JR., an individual, BENETA KIRBY, an individual, M.D. PERRY, an individual, and FRANCES O. PERRY, an individual (hereinafter collectively the "Grantor").

R E C I T A L S

1. Collectively, the Grantor is fee simple owner and contract purchaser of those certain properties referred to as the Ocala Meadows Development, which is described in Composite Exhibit "A" attached to and incorporated in this Agreement (hereafter the "Overall Property"), on a portion of which are located, or will be located, certain golf courses, common areas, and greenspaces. The Grantor warrants that said Overall Property is on this date free and clear of any encumbrances whatsoever.

2. The Granteor has designed and will convey to Grantee a wastewater treatment system located in Marion County, Florida.

3. The Grantor and Grantee desire that at least 330,000 GPD of Treated Wastewater, meeting all state and local quality restrictions be discharged onto Property for use by the Grantor in irrigating the Property, such discharge providing benefit to both the Grantor and the Grantee.

4. This Agreement is an arms-length transaction entered into to accommodate among other things: (1) the Grantee's Treated Wastewater Disposal needs; (2) certain subregional effluent disposal needs; and (3) to provide an alternate, substituted source of water to the Grantor.

5. The parties agree and acknowledge that the Grantee is foregoing other options for Treated Wastewater disposal in its long-range planning in reliance upon being able to dispose of Treated Wastewater perpetually on the Property.

FILE: 97103547
OR BOOK/PAGE: 2444/876

6. The Grantor and the Grantee covenant and agree that they have the power and authority to enter into this Agreement and bind themselves to the provisions of this Agreement.

ACCORDINGLY, in consideration of the above-stated Recitals and other good and valuable mutual consideration, the receipt and sufficiency of which is hereby acknowledged, the parties agree as follows:

SECTION 1. RECITALS. The above Recitals are true and correct, and form a material part of this Agreement.

SECTION 2. DEFINITIONS. For the purposes of this Agreement, the following terms shall have the following meanings:

2.1. "GPD" means gallons per day, average annual basis.

2.2. "Irrigation Facilities" shall mean pumping units with appurtenances (including the on-site irrigation pump), irrigation piping, valves and spray head assemblies all located on the Property.

2.3. "Storage Facility" shall mean the facilities which shall be utilized to meet applicable wet weather and other storage requirements.

2.4. "Treated Wastewater" shall mean wastewater treated to public access standards as promulgated by any state or local government agency charged with such standard setting authority (hereafter "State Environmental Agency").

2.5. "Wastewater Lines" shall mean pipelines, valves and appurtenances conveying treated wastewater to the Property under pressure from the treatment plant to the Holding Pond.

SECTION 3. TERMS OF EASEMENT.

3.1. Grant of Easement. The Grantor hereby grants to the Grantee a perpetual exclusive easement over each of the parcels described in Composite Exhibit "B" attached to and incorporated in this Agreement (hereafter "Property") for the purpose of:

(1) installing and modifying any necessary Treated Wastewater transmission lines and facilities (the "Wastewater Lines") to the Storage Facility, and installing and operating (if necessary as determined by Grantee) said

FILE: 97103547
OR BOOK/PAGE: 2444/877

Storage Facility as described in Subsection 3.2;

(2) transmitting Treated Wastewater that meets the State Environmental Agency both as to the quality of such wastewater and as to the volume of Treated Wastewater that can be discharged onto the Property upon completion of construction of any necessary Irrigation Facilities, Wastewater Lines and Storage Facility;

(3) maintaining the irrigation system and other facilities ("Irrigation Facilities") that are used for irrigating the Property should Grantor fail to perform such maintenance;

(4) detaining, retaining and storing Treated Wastewater in the Storage Facility; and

(5) operating the Irrigation Facilities as appropriate to allow the discharge of Treated Wastewater into the Storage Facility. Grantor shall operate the Irrigation System in such a manner and with sufficient frequency to distribute the required volume of Treated Wastewater onto the Property which shall be a specifically enforceable obligation. The actual volume of Treated Wastewater that can be lawfully disposed of shall be determined by an engineering analysis performed by Grantee which is subject to and must be reviewed and approved by the Department of Environmental Protection ("DEP"). The minimum volume of Treated Wastewater that Grantor shall accept on the Property shall be no less than 330,000 GPD, and the volume of Treated Wastewater that the Grantor shall accept on the Property shall be no more than the volume approved by the DER from time to time. Subject to and consistent with existing commitments to other parties under previous contracts with Grantee for delivery of Treated Wastewater, the Grantee shall use its best efforts to maximize the volume of Treated Wastewater delivered to Grantor. Nothing in this Agreement shall be construed to authorize Grantee to take any action that would unreasonably and adversely

FILE: 97103547
OR BOOK/PAGE: 2444/878

interfere with the use of the Grantor's Property as a golf course, so long as Grantee's capacity to discharge Treated Wastewater in the volume specified in this Subsection, on all or an adequate portion of Grantor's lands, is neither reduced, diminished nor impaired by Grantor's use. Grantee shall upon request execute such joinders, assurances or subordinations to Grantor, its mortgagees or purchasers, as are reasonably necessary to any change of use permitted under this Subsection.

Composite Exhibit "C," attached hereto and incorporated herein by reference, illustrates the effluent discharge and reclaimed water delivery system for the project which is contemplated by this Agreement.

3.2. Obligations of Grantee. In the exercise of its rights under this agreement, the Grantee:

(1) shall not interfere unreasonably with Grantor's use of the Property;

(2) shall use its best efforts to conduct its activities on the Property owned by Grantor so as to avoid any unreasonable and adverse interference with the normal use of the Property; and

(3) shall obtain, at its expense, all governmental permits, consents and approvals as it considers necessary for the operation of the Irrigation Facilities.

3.3. Obligations of Grantor. The Grantor shall:

(1) at its sole expense, construct and maintain the Irrigation Facilities, the on-site irrigation pump, certain improvements to the now existing Irrigation Facilities, including a backflow preventer or air gap, level control, and sprinkler appurtenances as necessary in good, operable condition and repair and any necessary off-site Wastewater Lines and facilities necessary to transmit Treated Wastewater from the Wastewater Treatment Plant into a Storage Facility and thence to the Property for ultimate disposal with the point

of connection between the Wastewater Lines and the Storage Facility to be mutually determined by the parties at a later date;

(2) at its sole expense, operate all the said Irrigation Facilities and the on-site irrigation pump and appurtenances in such a way so as to permit the Grantee to discharge into the Storage Facility all the Treated Wastewater it is authorized to discharge pursuant to Subsection 3.1 of this agreement;

(3) fully cooperate with and assist the Grantee in obtaining and complying with all necessary permits, consents and approvals as are required by the State Environmental Agency and other governmental agencies having jurisdiction over the Property, as well as the discharge and storage of Treated Wastewater provided, however, Grantor shall have no obligation to operate the said Irrigation Facilities in a manner that would interfere unreasonably and adversely with the use of the Property, so long as the Grantee's capacity to discharge wastewater is neither reduced nor diminished by Grantor's use; and

(4) otherwise cooperate with the Grantee to enable the Grantee to exercise all its rights under this Agreement.

3.4. Defaults; Remedies. If Grantor fails to perform any of its obligations under this easement, the Grantee itself may perform these obligations and shall be entitled to reimbursement from Grantor for any costs and expenses reasonably incurred in connection with the performance of these obligations.

3.5. Permits and Approvals. The parties agree that the implementation of this Agreement will be subject to the exercise of the police power by various state and local agencies. The Grantee agrees that it will at its expense obtain and maintain all necessary governmental permits and approvals for the provision of irrigation of the Property with Treated Wastewater. The Grantor shall use its best efforts to assist Grantee in obtaining any such permits or approvals such that the maximum volume of properly Treated Wastewater can be disposed of on the Property consistent with Subsection 3.1 hereof; and toward that end, shall execute and consent to the filing of any necessary documents and applications

FILE: 97103547
OR BOOK/PAGE: 2444/880

with governmental agencies to accomplish the purposes set forth in this Subsection.

3.6. Reporting and Monitoring. The Grantor shall keep a daily log of the total gallons per week of Treated Wastewater that is applied to the Property. This information shall be transmitted monthly to the Grantee on forms provided by the Grantee. The Grantee shall be responsible for the background groundwater quality and compliance groundwater quality, sampling and reporting.

3.8. Exclusive Easement for Use. Grantor and the Grantee agree that the Grantee has the exclusive right for the discharge of Treated Wastewater through the Irrigation Facilities and onto the Property or into the Holding Pond. If Grantee is unable to supply enough Treated Wastewater to provide for Grantor's irrigation needs, then, subject to any required permits or governmental approvals, Grantor may supplement the supply of Treated Wastewater by pumping from its existing irrigation wells or other permitted source, into the Holding Pond or directly into the Irrigation Facilities, so long as such supplementation does not impair the ability of Grantee to transmit and dispose of its maximum available volume of Treated Wastewater onto the Property.

3.9. Indemnification. The Grantee shall indemnify and hold Grantor harmless from any injury or damage to Grantor, its officers, agents and employees and from any and all liability for injury to third persons, including death or damage to the Property of third persons while lawfully upon the Property occurring by reason of any overt or negligent act or omission of the Grantee, its agents or employees. The Grantor shall indemnify and hold Grantee harmless from any injury or damage to Grantee, its officers, agents and employees and from any and all liability for injury to third persons, including death or damage to the Property of third persons while lawfully upon the Property occurring by reason of any overt or negligent act or omission of the Grantor, its agents or employees. Grantee shall also be solely responsible for enforcing its rights under this Agreement against any third party interfering therewith. Nothing contained in this Agreement shall limit Grantee's right to protect its rights from interference by a third party not a party hereto, which rights are hereby determined to be equal to the replacement value of alternative effluent disposal facilities.

3.10. Enforcement. A default by either party under this Agreement shall entitle the other party to all remedies available at law or in equity, including, but not limited to the right of damages, injunctive relief and specific performance.

FILE: 97103547
OR BOOK/PAGE: 2444/881

3.11. Attorney's Fees. If, on account of any breach or default by either party of its obligations under the terms and conditions of this Agreement, it shall become necessary for the other party to utilize any attorney to enforce or defend its rights or remedies hereunder, the prevailing party shall be entitled to recover reasonable attorney's fees and suit costs incurred by said prevailing party.

SECTION 4. RIGHT-OF-ENTRY. During the term of this Agreement, the Grantee shall have the irrevocable right of entry, access, ingress, and egress into, over, across, upon and through the Overall Property described in Composite Exhibit "A" hereof for purposes of this Agreement, inspection, sample taking, borings, soils tests, testing, and monitoring of the Property. The Grantee shall have the right at any time to enter upon the Property and inspect and review the operation and maintenance of any of the Irrigation Facilities constructed or installed thereon and operate and maintain said Facilities in the event of an emergency threatening the public health or welfare. If, in the reasonable opinion of the Grantee, the Grantor is not operating or maintaining said Facilities properly, then the Grantee shall give the Grantor written notice to make such repairs or improve such operation and maintenance procedures and, if the Grantor fails or refuses to do so within thirty days after notice of receipt, then at the option of the Grantee, the Grantee shall have the right to enter upon the Property and undertake said responsibilities and charge the Grantor as reasonable and necessary costs incurred thereby; provided, however, nothing herein shall relieve the Grantor from the continuing obligation of operation and maintenance of said Facilities. Should the Grantee assume the responsibility to operate and maintain said Facilities located upon the Property, it shall have no obligation thereby to maintain said lands for any purpose other than the disposal of Treated Wastewater. Any damage caused to the Property by the actions of Grantee under this Section 4 shall be repaired or fixed by Grantee at its expense.

SECTION 5. NOTICE. Any notice or document required or permitted to be delivered under this Agreement or the easement to be granted hereunder shall be in writing and shall be deemed delivered at the earlier of (1) the date received, or (2) three (3) business days after the date deposited in an United States Postal Service depository, postage pre-paid, registered or certified mail, return receipt requested, addressed to the Grantor or Grantee, as the case may be, at the addresses set forth opposite their names below:

FILE: 97103547
OR BOOK/PAGE: 2444/882

Grantee: Marion County
601 S.E. 25th Avenue
Ocala, Florida 34471-2690
Attention: County Administrator

With a Copy to: Thomas A. Cloud
Gray, Harris & Robinson, P.A.
210 East Pine Street
Orlando, Florida 32801

Grantor: Siemens Ocala Corp.
4800 North Federal Highway, Suite 202-E
Boca Raton, Florida 33431
Attention: Richard Siemens

SECTION 6. NONWAIVER. A failure by either party to demand compliance with a provision of this Agreement will not constitute a waiver of that party's right to demand compliance with the provision thereafter.

SECTION 7. SUCCESSORS, HEIRS AND ASSIGNS. This Agreement is binding upon and inures to the benefit of the parties and their respective successors, heirs and assigns.

SECTION 8. GOVERNING LAW. This Agreement shall be governed, construed, and controlled in accordance with the laws and rules of the State of Florida.

SECTION 9. RECORDATION. Upon the effective date of this Agreement, the Grantee shall have the right to record this Agreement in the Public Records of Marion County, Florida, at its expense.

SECTION 10. ENTIRE AGREEMENT. This is the entire Agreement between the parties, covering everything agreed upon or understood in the transaction, and supersedes all previous letters, correspondence, drafts, and other agreements or documents on the same subject. There are no oral promises, conditions, representations, understandings, interpretations, or terms of any kind as conditions or inducements to the execution hereof in effect between the parties. No change or addition is to be made to this Agreement, except by written agreement executed by the parties.

SECTION 11. TIME OF THE ESSENCE. Time is hereby declared to be of the essence to this contract.

FILE: 97103547
OR BOOK/PAGE: 2444/883

SECTION 12. EFFECTIVE DATE OF THIS AGREEMENT. This Agreement will become effective upon execution.

IN WITNESS WHEREOF, the parties have executed this Agreement the day and year first above written.

Signed, sealed and delivered in the presence of

GRANTOR:

x: Deane C. Wilson
x: Janet D. Cronenberg

[Signature]
PLATO KIRBY, JR., individually

STATE OF FLORIDA
COUNTY OF Indian River

The foregoing instrument was acknowledged before me this 24th day of Sept, 1996, by PLATO KIRBY, JR. He is personally known to me or has produced as identification and did (did not) take an oath.

[Signature]
Signature of Person Taking Acknowledgment
SUSANNE PETRUZZELLO
Name of Acknowledger Typed, Printed or Stamped
Adv
Title or Rank

Serial Number, if any.



"OFFICIAL SEAL"
Susanne Petruzzello
My Commission Expires 11/12/96
Commission #CC 241576

FILE: 97103547
OR BOOK/PAGE: 2444/884

Signed, sealed and delivered
in the presence of

GRANTOR:

x: Diane C. Wilson
x: James D. Cronenberg

Beneta Kirby
BENETA KIRBY, individually

STATE OF FLORIDA
COUNTY OF Indian River

The foregoing instrument was acknowledged before me this 24th
day of Sept, 1996, by BENETA KIRBY. She is personally known
to me or has produced _____ as
identification and did (did not) take an oath.

Susanne Petruzzello
Signature of Person Taking Acknowledgment
SUSANNE PETRUZZELLO
Name of Acknowledger Typed, Printed or Stamped
HVP

Title or Rank

Serial Number, if any.



"OFFICIAL SEAL"
Susanne Petruzzello
My Commission Expires 11/12/96
Commission #CC 241576

FILE: 97103547
OR BOOK/PAGE: 2444/885

Signed, sealed and delivered
in the presence of

GRANTOR:

x: M. Dean Perry Jr.
M. Dean Perry, Jr.
x: Hilda P. Surrency
Hilda P. Surrency

M.D. Perry
M.D. PERRY, individually

STATE OF FLORIDA
COUNTY OF MARION

The foregoing instrument was acknowledged before me this 23rd
day of September, 1996, by M.D. PERRY. He is personally known to
me or has produced _____ as identification
and ~~did~~ (did not) take an oath.

Hilda P. Surrency
Signature of Person Taking Acknowledgment

Name of Acknowledger Typed, Printed or Stamped

Title or Rank

Serial Number, if any.

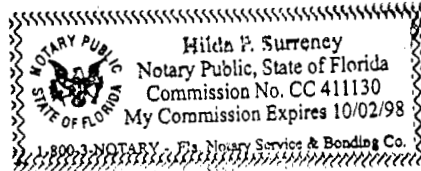

FILE: 97103547
OR BOOK/PAGE: 2444/886

44 OF 47

Signed, sealed and delivered
in the presence of

GRANTOR:

x: M. Dean Perry, Jr.
M. Dean Perry, Jr.
x: Hilda P. Surrency
Hilda P. Surrency

Frances O. Perry
FRANCES O. PERRY, individually

STATE OF FLORIDA
COUNTY OF WABICK

The foregoing instrument was acknowledged before me this 23rd
day of September, 1996, by FRANCES O. PERRY. She is personally
known to me or has produced _____ as
identification and ~~did~~ (did not) take an oath.

Hilda P. Surrency
Signature of Person Taking Acknowledgment

Name of Acknowledger Typed, Printed or Stamped

Title or Rank

Serial Number, if any.

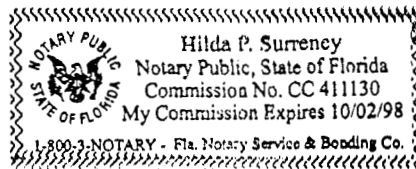

FILE: 97103547
OR BOOK/PAGE: 2444/887

Signed, sealed and delivered in the presence of:

GRANTOR:

SIEMENS OCALA CORP., a Florida corporation

(x) Roy Christie

Name: Roy CHRISTIE

(x) R. Siemens

Name: Rob Siemens

By: Richard Siemens
Richard Siemens
President

(CORPORATE SEAL)

STATE OF Florida

COUNTY OF Palm Beach

The foregoing instrument was acknowledged before me this 25 day of September, 1996 by Richard Siemens, President of SIEMENS OCALA CORP., a Florida corporation. He is personally known to me or has produced _____ as identification and did (did not) take an oath.



Diane Bucci
Signature of Person Taking Acknowledgement

DIANE BUCCI
Name of Acknowledger Typed, Printed or Stamped

Title or Rank

Serial Number, if any.

FILE: 97103547
OR BOOK/PAGE: 2444/888

Signed, sealed and delivered
in the presence of:

GRANTEE:

MARION COUNTY, FLORIDA

(x) Madeline Williamson

Name: Madeline Williamson

By: Steve F. Henning
Steve F. Henning, Chairman
Board of COUNTY Commissioners

(x) Miriam Pauley

Name: Miriam Pauley

Attest: Thomas P. Klinker
Thomas P. Klinker, Clerk

STATE OF FLORIDA
COUNTY OF MARION

The foregoing instrument was acknowledged before me this
1st day of OCTOBER, 1996, by Steve F. Henning, Chairman
of The Board of County Commissioners of Marion County, Florida, on
behalf of MARION COUNTY. He is personally known to me or has
produced n/a as identification and ~~did~~
(did not) take an oath.

Miriam Pauley
Signature of Person Taking Acknowledgement
Miriam Pauley
Name of Acknowledger Typed, Printed or Stamped
Notary Public
Title or Rank
Commission #CC319909
Serial Number, if any
Expires: October 29, 1997

FOR THE USE AND RELIANCE
OF MARION COUNTY ONLY.
APPROVED AS TO FORM.

October 4, 1996
Thomas A. Cloud
Thomas A. Cloud, Utility Counsel

F:\USR\AYURKO\MARION\OCALMEAD.EAS

FILE: 97103547
OR BOOK/PAGE: 2444/889