

129



RECEIVED-FPSC

00 MAY -4 PM 4:41

RECORDS AND REPORTING

Susan S. Masterton  
Attorney

Law/External Affairs  
Post Office Box 2214  
Tallahassee, FL 32318-2214  
Voice 850 599 1560  
Fax 850 878 0777  
susan.masterton@mail.sprint.com

May 4, 2000

Ms. Blanca S. Bayo, Director  
Division of Records and Reporting  
Florida Public Service Commission  
2540 Shumard Oak Boulevard  
Tallahassee, Florida 32399-0850

000549-TP

Re: Petition of Sprint-Florida, Incorporated  
for Approval of a Interconnection and Resale  
Agreement with USA Digital, Inc.

Dear Ms. Bayo:

Enclosed for filing is the original and five (5) copies of  
Sprint-Florida, Inc.'s Petition for approval of a  
Interconnection and Resale Agreement with USA Digital, Inc.

Please acknowledge receipt and filing of the above by  
stamping the duplicate copy of this letter and returning the  
same to this writer.

Thank you for your assistance in this matter.

Sincerely,

  
Susan S. Masterton FOR

SSM/th

Enclosures

DOCUMENT NUMBER-DATE

05623 MAY-48

FPSC-RECORDS/REPORTING

BEFORE THE FLORIDA PUBLIC SERVICE COMMISSION

In re: Petition for Approval )  
of Interconnection and Resale )  
Agreement Between )  
Sprint- Florida, Incorporated )  
And USA Digital, Inc. )

Docket No. 000549-TP

Filed: May 4, 2000

PETITION OF SPRINT-FLORIDA, INCORPORATED  
FOR APPROVAL OF INTERCONNECTION AND RESALE AGREEMENT  
WITH USA DIGITAL, INC.

Sprint-Florida, Incorporated (Sprint-Florida) files this Petition with the Florida Public Service Commission seeking approval of an Interconnection and Resale Agreement, which Sprint-Florida has entered with USA Digital, Inc. In support of this Petition, Sprint-Florida states:

Florida Telecommunications law, Chapter 364, Florida Statutes as amended, requires local exchange carriers such as Sprint-Florida to negotiate "mutually acceptable prices, terms and conditions of interconnection and for the resale of services and facilities" with alternative local exchange carriers. Section 364.162, Florida Statutes (1996).

2. The Telecommunications Act of 1996, requires that any such "agreement adopted by negotiation or arbitration shall be submitted for approval to the State Commission" 47 U.S.C. §252(e).

DOCUMENT NUMBER-DATE

05623 MAY-48

FPSC-RECORDS/REPORTING

3. In accordance with the above provisions, Sprint-Florida has entered an Agreement with USA Digital, Inc., which is or will be a carrier certificated as an alternative local exchange carrier as that term is defined in Section 364.02(1), Florida Statutes (1996). This Agreement was executed on April 14, 2000, and is attached hereto as Attachment A.

4. Under the Federal Act, an agreement can be rejected by the State Commission only if the commission finds that the agreement or any portion thereof discriminates against a telecommunications carrier not a party to the agreement or if the implementation of that agreement is not consistent with the public interest, convenience and necessity. 47 U.S.C. §252(e)(2).

5. The Agreement with USA Digital, Inc. does not discriminate against other similarly situated carriers, which may order services and facilities from Sprint-Florida under similar terms and conditions. The Agreement is also consistent with the public interest, convenience and necessity. As such, Sprint-Florida seeks approval of the Agreement from the Florida Public Service Commission as required by the Federal statutory provisions noted above.

Wherefore, Sprint-Florida respectfully requests that the Florida Public Service Commission approve the Interconnection and Resale agreement between Sprint-Florida and USA Digital, Inc.

Respectfully submitted this 4th day of May, 2000.

Sprint-Florida, Incorporated

---

Susan S. Masterton  
Attorney  
Sprint-Florida, Incorporated  
Post Office Box 2214  
MS: FLTLHO0107  
Tallahassee, Florida 32316  
850/599-1560



**MASTER INTERCONNECTION AND RESALE AGREEMENT  
FOR THE STATE OF FLORIDA**

*April 11, 2000*

*USA DIGITAL, INC.*

*and*

*SPRINT-FLORIDA, INCORPORATED*

## TABLE OF CONTENTS

	<u>Page No.</u>
<b>PART A -- DEFINITIONS .....</b>	<b>2</b>
<b>1. DEFINED TERMS .....</b>	<b>2</b>
<b>PART B – GENERAL TERMS AND CONDITIONS.....</b>	<b>11</b>
<b>2. SCOPE OF THIS AGREEMENT .....</b>	<b>11</b>
<b>3. REGULATORY APPROVALS.....</b>	<b>11</b>
<b>4. TERM AND TERMINATION.....</b>	<b>12</b>
<b>5. POST EXPIRATION INTERIM SERVICE ARRANGEMENTS .....</b>	<b>13</b>
<b>6. CHARGES AND PAYMENT .....</b>	<b>13</b>
<b>7. AUDITS AND EXAMINATIONS .....</b>	<b>14</b>
<b>8. INTELLECTUAL PROPERTY RIGHTS.....</b>	<b>15</b>
<b>9. LIMITATION OF LIABILITY .....</b>	<b>16</b>
<b>10. INDEMNIFICATION .....</b>	<b>17</b>
<b>11. BRANDING.....</b>	<b>18</b>
<b>12. REMEDIES .....</b>	<b>18</b>
<b>13. CONFIDENTIALITY AND PUBLICITY .....</b>	<b>18</b>
<b>14. DISCLAIMER OF WARRANTIES.....</b>	<b>20</b>
<b>15. ASSIGNMENT AND SUBCONTRACT.....</b>	<b>20</b>
<b>16. GOVERNING LAW .....</b>	<b>20</b>
<b>17. RELATIONSHIP OF PARTIES .....</b>	<b>21</b>
<b>18. NO THIRD PARTY BENEFICIARIES.....</b>	<b>21</b>
<b>19. NOTICES.....</b>	<b>21</b>
<b>20. WAIVERS .....</b>	<b>22</b>
<b>21. SURVIVAL.....</b>	<b>22</b>
<b>22. FORCE MAJEURE.....</b>	<b>22</b>
<b>23. DISPUTE RESOLUTION.....</b>	<b>23</b>

24. COOPERATION ON FRAUD.....	23
25. TAXES .....	23
26. AMENDMENTS AND MODIFICATIONS .....	24
27. SEVERABILITY .....	24
28. HEADINGS NOT CONTROLLING.....	24
29. ENTIRE AGREEMENT .....	24
30. COUNTERPARTS.....	24
31. SUCCESSORS AND ASSIGNS .....	25
32. IMPLEMENTATION PLAN.....	25
33. FEDERAL JURISDICTIONAL AREAS.....	26
<b>PART C GENERAL PRINCIPLES.....</b>	<b>27</b>
34. USE OF FACILITIES. ....	27
35. PRICE SCHEDULE .....	27
36. LOCAL SERVICE RESALE.....	27
37. INTERCONNECTION AND RECIPROCAL COMPENSATION.....	27
38. UNBUNDLED NETWORK ELEMENTS .....	28
TABLE ONE.....	55
<b>PART D LOCAL RESALE .....</b>	<b>56</b>
39. TELECOMMUNICATIONS SERVICES PROVIDED FOR RESALE .....	56
40. GENERAL TERMS AND CONDITIONS.....	56
<b>PART E NETWORK ELEMENTS .....</b>	<b>59</b>
41. GENERAL.....	59
42. UNBUNDLED NETWORK ELEMENTS .....	59
43. BONA FIDE REQUEST PROCESS FOR FURTHER UNBUNDLING.....	60
44. NETWORK INTERFACE DEVICE.....	61
45. LOOP .....	61
46. SUBLOOPS.....	66

47. LOCAL SWITCHING.....	66
48. TANDEM SWITCHING.....	67
49. TRANSPORT.....	69
50. SIGNALING SYSTEMS AND DATABASES.....	70
51. OPERATIONS SUPPORT SYSTEMS (OSS).....	74
<b>PART F INTERCONNECTION.....</b>	<b>75</b>
52. LOCAL INTERCONNECTION TRUNK ARRANGEMENT.....	75
53. INTERCONNECTION COMPENSATION MECHANISMS.....	76
54. SIGNALING.....	78
55. NETWORK SERVICING.....	78
56. NETWORK MANAGEMENT.....	80
57. USAGE MEASUREMENT.....	80
58. TRANSIT TRAFFIC.....	81
59. RESPONSIBILITIES OF THE PARTIES.....	82
<b>PART G INTERIM NUMBER PORTABILITY.....</b>	<b>84</b>
60. SPRINT PROVISION OF INTERIM NUMBER PORTABILITY.....	84
61. INTERIM NUMBER PORTABILITY.....	84
62. REQUIREMENTS FOR INP.....	85
<b>PART H LOCAL NUMBER PORTABILITY.....</b>	<b>88</b>
63. INTRODUCTION.....	88
64. TRANSITION FROM INP TO LNP.....	88
65. TESTING.....	89
66. ENGINEERING AND MAINTENANCE.....	89
67. E911/911.....	90
68. BILLING.....	90
<b>PART I GENERAL BUSINESS REQUIREMENTS.....</b>	<b>91</b>
69. PROCEDURES.....	91



70. ORDERING AND PROVISIONING .....92

71. BILLING ..... 99

72. PROVISION OF SUBSCRIBER USAGE DATA .....100

73. GENERAL NETWORK REQUIREMENTS .....105

74. MISCELLANEOUS SERVICES AND FUNCTIONS .....107

PART J REPORTING STANDARDS .....119

75. GENERAL.....119

76. PARITY AND QUALITY MEASUREMENTS .....119

## **INTERCONNECTION AND RESALE AGREEMENT**

This Interconnection and Resale Agreement (the "Agreement"), entered into this 11<sup>TH</sup> day of April, 2000, is entered into by and between USA DIGITAL, INC. ("CLEC"), and SPRINT-FLORIDA, INCORPORATED ("Sprint"), a FLORIDA corporation, to establish the rates, terms and conditions for local interconnection, local resale, and purchase of unbundled network elements (individually referred to as the "service" or collectively as the "services").

WHEREAS, the Parties wish to interconnect their local exchange networks for the purposes of transmission and termination of calls, so that customers of each can receive calls that originate on the other's network and place calls that terminate on the other's network, and for CLEC's use in the provision of exchange access ("Local Interconnection"); and

WHEREAS, CLEC wishes to purchase Telecommunications Services for resale to others, and Sprint is willing to provide such service; and

WHEREAS, CLEC wishes to purchase unbundled network elements, ancillary services and functions and additional features ("Network Elements"), and to use such services for itself or for the provision of its Telecommunications Services to others, and Sprint is willing to provide such services; and

WHEREAS, the Parties intend the rates, terms and conditions of this Agreement, and their performance of obligations thereunder, to comply with the Communications Act of 1934, as amended (the "Act"), the Rules and Regulations of the Federal Communications Commission ("FCC"), and the orders, rules and regulations of the FLORIDA PUBLIC SERVICE COMMISSION (the "Commission"); and

WHEREAS, the parties wish to replace any and all other prior agreements, written and oral, applicable to the state of FLORIDA.

Now, therefore, in consideration of the terms and conditions contained herein, CLEC and Sprint hereby mutually agree as follows:

## PART A -- DEFINITIONS

### 1. DEFINED TERMS

- 1.1. Capitalized terms defined in this Article shall have the meanings as set forth herein. Other terms used but not defined herein will have the meanings ascribed to them in the Act or in the Rules and Regulations of the FCC or the Commission. The Parties acknowledge that other terms appear in this Agreement, which are not defined or ascribed as stated above. The parties agree that any such terms shall be construed in accordance with their customary usage in the telecommunications industry as of the Effective Date of this Agreement.
- 1.2. "911 Service" means a universal telephone number which gives the public direct access to the Public Safety Answering Point (PSAP). Basic 911 service collects 911 calls from one or more local exchange switches that serve a geographic area. The calls are then sent to the correct authority designated to receive such calls.
- 1.3. "Access Services" refers to interstate and intrastate switched access and private line transport services.
- 1.4. "Act" means the Communications Act of 1934, as amended.
- 1.5. "Affiliate" is as defined in the Act.
- 1.6. "Automated Message Accounting (AMA)" is the structure inherent in switch technology that initially records telecommunication message information. AMA format is contained in the Automated Message Accounting document, published by Telcordia as GR-1100-CORE which defines the industry standard for message recording.
- 1.7. "Automatic Location Identification (ALI)" is a feature developed for E911 systems that provides for a visual display of the caller's telephone number, address and the names of the Emergency Response agencies that are responsible for that address.
- 1.8. "Automatic Location Identification/Data Management System (ALI/DMS)" means the emergency service (E911/911) database containing subscriber location information (including name, address, telephone number, and sometimes special information from the local service provider) used to determine to which Public Safety Answering Point (PSAP) to route the call.
- 1.9. "Automatic Number Identification (ANI)" is a feature that identifies and displays the number of a telephone line that originates a call.
- 1.10. "Automatic Route Selection (ARS)" is a service feature associated with a specific grouping of lines that provides for automatic selection of the least expensive or most appropriate transmission facility for each call based on criteria programmed into the system.

- 1.11. "ATU – C" refers to an ADSL Transmission Unit – Central Office.
- 1.12. "Busy Line Verify/Busy Line Verify Interrupt (BLV/BLVI)" means an operator call in which the caller inquires as to the busy status of, or requests an interruption of a call on another subscriber's telephone line.
- 1.13. "Business Day(s)" means the days of the week excluding Saturdays, Sundays, and all Sprint holidays.
- 1.14. "Carrier Access Billing System (CABS)" is the system which is defined in a document prepared under the direction of the Billing Committee of the OBF. The CABS document is published by Telcordia in Volumes 1, 1A, 2, 3, 3A, 4 and 5 as Special Reports SR-OPT-001868, SR-OPT-001869, SR-OPT-001871, SR-OPT-001872, SR-OPT-001873, SR-OPT-001874, and SR-OPT-001875, respectively, and contains the recommended guidelines for the billing of access and other connectivity services. Sprint's carrier access billing system is its Carrier Access Support System (CASS). CASS mirrors the requirements of CABS.
- 1.15. "Common Channel Signaling (CCS)" is a method of digitally transmitting call set-up and network control data over a digital signaling network fully separate from the public switched telephone network that carries the actual call.
- 1.16. "Central Office Switches" ("COs") - are switching facilities within the public switched telecommunications network, including, but not limited to:
  - 1.16.1. "End Office Switches" ("EOs") are switches from which end user Telephone Exchange Services are directly connected and offered.
  - 1.16.2. "Tandem Switches" are switches that are used to connect and switch trunk circuits between and among Central Office Switches.
  - 1.16.3. "Remote Switches" are switches that are away from their host or control office. All or most of the central control equipment for the remote switch is located at the host or control office.
- 1.17. "Centrex" means a Telecommunications Service associated with a specific grouping of lines that uses central office switching equipment for call routing to handle direct dialing of calls, and to provide numerous private branch exchange-like features.
- 1.18. "CLASS/LASS" (Telcordia Service Mark) refers to service features that utilize the capability to forward a calling party's number between end offices as part of call setup. Features include Automatic Callback, Automatic Recall, Caller ID, Call Trace, and Distinctive Ringing.
- 1.19. "Commission" means the FLORIDA PUBLIC SERVICE COMMISSION.
- 1.20. "Common Transport" provides a local interoffice transmission path between the Sprint Tandem Switch and a Sprint or CLEC end office switch. Common Transport is shared between multiple customers and is required to be switched at

the Tandem.

- 1.21. "Confidential and/or Proprietary Information" has the meaning set forth in Article 11 of Part A -- General Terms and Conditions.
- 1.22. "Control Office" is an exchange carrier center or office designated as the Party's single point of contact for the provisioning and maintenance of its portion of local interconnection arrangements.
- 1.23. "Custom Calling Features" means a set of Telecommunications Service features available to residential and single-line business customers including call-waiting, call-forwarding and three-party calling.
- 1.24. "Customer Proprietary Network Information (CPNI)" is as defined in the Act.
- 1.25. "Database Management System (DBMS)" is a computer process used to store, sort, manipulate and update the data required to provide selective routing and ALI.
- 1.26. "Dedicated Transport" provides a local interoffice transmission path between Sprint and/or CLEC central offices. Dedicated Transport is limited to the use of a single customer and does not require switching at a Tandem.
- 1.27. "Directory Assistance Database" refers to any subscriber record used by Sprint in its provision of live or automated operator-assisted directory assistance including but not limited to 411, 555-1212, NPA-555-1212.
- 1.28. "Directory Assistance Services" provides listings to callers. Directory Assistance Services may include the option to complete the call at the caller's direction.
- 1.29. "DSLAM" refers to a Digital Subscriber Line Access Multiplexer.
- 1.30. "Duct" is a single enclosed path to house facilities to provide telecommunications services.
- 1.31. "Enhanced 911 Service (E911)" means a telephone communication service which will automatically route a call dialed "9-1-1" to a designated public safety answering point (PSAP) attendant and will provide to the attendant the calling party's telephone number and, when possible, the address from which the call is being placed and the Emergency Response agencies responsible for the location from which the call was dialed.
- 1.32. "Effective Date" is the date referenced in the opening paragraph on page 1 of the Agreement, unless otherwise required by the Commission.
- 1.33. "Electronic Interface" means access to operations support systems consisting of preordering, ordering, provisioning, maintenance and repair and billing functions.
- 1.34. "Emergency Response Agency" is a governmental entity authorized to respond to requests from the public to meet emergencies.
- 1.35. "Emergency Service Number (ESN)" is a number assigned to the ALI and

selective routing databases for all subscriber telephone numbers. The ESN designates a unique combination of fire, police and emergency medical service response agencies that serve the address location of each in-service telephone number.

- 1.36. "EMI" (Exchange Message Interface System) is the Industry standard for exchanging telecommunications message information for billable, non-billable, sample settlement and study records. The EMI is published by ATIS (Alliance for Telecommunications Industry Solutions)."
- 1.37. "End Date" is the date this Agreement terminates as referenced in the opening paragraph.
- 1.38. "FCC" means the Federal Communications Commission.
- 1.39. "Grandfathered Service" means service which is no longer available for new customers and is limited to the current customer at their current locations with certain provisioning limitations, including but not limited to upgrade denials, feature adds/changes and responsible/billing party.
- 1.40. "Incumbent Local Exchange Carrier (ILEC)" is as defined in the Act.
- 1.41. "Interexchange Carrier (IXC)" means a provider of interexchange telecommunications services.
- 1.42. "Interim Number Portability (INP)" is a service arrangement whereby subscribers who change local service providers may retain existing telephone numbers without impairment of quality, reliability, or convenience when remaining at their current location or changing their location within the geographic area served by the initial carrier's serving central office. Upon implementation of Local Number Portability, defined herein, INP services will be discontinued.
- 1.43. "Line Information Data Base (LIDB)" means a Service Control Point (SCP) database that provides for such functions as calling card validation for telephone line number cards issued by Sprint and other entities and validation for collect and billed-to-third services.
- 1.44. "Local Loop" refers to a transmission path between the main distribution frame [cross-connect], or its equivalent, in a Sprint Central Office or wire center, and up to the Network Interface Device at a customer's premises, to which CLEC is granted exclusive use. This includes, but is not limited to, two-wire and four-wire copper analog voice-grade loops, two-wire and four-wire loops that are conditioned to transmit the digital signals needed to provide services such as ISDN and DS1-level signals.
- 1.45. "Local Number Portability (LNP)" means the ability of users of Telecommunications Services to retain, at the same Sprint served rate center, existing telecommunications numbers without impairment of quality, reliability, or convenience when switching from one telecommunications carrier to another.

- 1.46. "Local Service Request (LSR)" means an industry standard form or a mutually agreed upon change thereof, used by the Parties to add, establish, change or disconnect local services.
- 1.47. "Local Traffic," for the purposes of this Agreement the Parties shall agree that "Local Traffic" means traffic (excluding CMRS traffic) that is originated and terminated within Sprint's local calling area, or mandatory expanded area service (EAS) area, as defined by State commissions or, if not defined by State commissions, then as defined in existing Sprint tariffs. For this purpose, Local Traffic does not include any traffic that is transmitted to or returned from the Internet at any point during the duration of the transmission between the Parties. Neither Party waives its' rights to participate and fully present its' respective positions in any proceeding dealing with the compensation for Internet traffic.
- 1.48. "Multiple Exchange Carrier Access Billing (MECAB)" refers to the document prepared by the Billing Committee of the ATIS Ordering and Billing Forum (OBF). The MECAB document contains the recommended guidelines for the billing of an access service provided to a customer by two or more providers or by one provider in two or more states within a single LATA.
- 1.49. "Multiple Exchange Carrier Ordering And Design" ("MECOD") refers to the guidelines for Access Services - Industry Support Interface, a document developed by the Ordering/Provisioning Committee under the auspices of the Ordering and Billing Forum (OBF), which functions under the auspices of the Carrier Liaison Committee (CLC) of the Alliance for Telecommunications Industry Solutions (ATIS). The MECOD document, published by Telcordia as Special Report SR STS-002643, establishes recommended guidelines for processing orders for access service which is to be provided by two or more telecommunications carriers.
- 1.50. "North American Numbering Plan" ("NANP") means the plan for the allocation of unique 10-digit directory numbers consisting of a three-digit area code, a three-digit office code, and a four-digit line number. The plan also extends to format variations, prefixes, and special code applications.
- 1.51. "National Emergency Number Association (NENA)" is an association with a mission to foster the technological advancement, availability and implementation of 911 nationwide.
- 1.52. "Network Element" as defined in the Act.
- 1.53. "Numbering Plan Area (NPA)" (sometimes referred to as an area code) is the three-digit indicator which is designated by the first three digits of each 10-digit telephone number within the NANP. Each NPA contains 800 possible NXX Codes. There are two general categories of NPA, "Geographic NPAs" and "Non-Geographic NPAs." A "Geographic NPA" is associated with a defined geographic area, and all telephone numbers bearing such NPA are associated with services provided within that geographic area. A "Non-Geographic NPA," also known as a "Service Access Code (SAC Code)" is typically associated with a

specialized telecommunications service which may be provided across multiple geographic NPA areas; 500, 800, 900, 700, and 888 are examples of Non-Geographic NPAs.

- 1.54. "NXX," "NXX Code," "NNX," "COC," "Central Office Code," or "CO Code" is the three-digit switch entity indicator which is defined by the fourth, fifth and sixth digits of a 10-digit telephone number within NANP.
- 1.55. "OBF" means the Ordering and Billing Forum, which functions under the auspices of the Carrier Liaison Committee (CLC) of the Alliance for Telecommunications Industry Solutions (ATIS)
- 1.56. "Operator Systems" is the Network Element that provides operator and automated call handling with billing, special services, subscriber telephone listings, and optional call completion services.
- 1.57. "Operator Services" provides for:
  - 1.57.1. operator handling for call completion (e.g., collect calls);
  - 1.57.2. operator or automated assistance for billing after the subscriber has dialed the called number (e.g., credit card calls); and
  - 1.57.3. special services (e.g., BLV/BLI, Emergency Agency Call).
- 1.58. "Parity" means, subject to the availability, development and implementation of necessary industry standard Electronic Interfaces, the provision by Sprint of services, Network Elements, functionality or telephone numbering resources under this Agreement to CLEC, including provisioning and repair, at least equal in quality to those offered to Sprint, its Affiliates or any other entity that obtains such services, Network Elements, functionality or telephone numbering resources. Until the implementation of necessary Electronic Interfaces, Sprint shall provide such services, Network Elements, functionality or telephone numbering resources on a non-discriminatory basis to CLEC as it provides to its Affiliates or any other entity that obtains such services, Network Elements, functionality or telephone numbering resources.
- 1.59. "P.01 Transmission Grade Of Service (GOS)" means a trunk facility provisioning standard with the statistical probability of no more than one call in 100 blocked on initial attempt during the average busy hour.
- 1.60. "Parties" means, jointly, SPRINT-FLORIDA, INCORPORATED and USA DIGITAL, INC., and no other entity, affiliate, subsidiary or assign.
- 1.61. "Party" means either SPRINT-FLORIDA, INCORPORATED or USA DIGITAL, INC., and no other entity, affiliate, subsidiary or assign.
- 1.62. "Percent Local Usage (PLU)" is a calculation which represents the ratio of the local minutes to the sum of local and intraLATA toll minutes between exchange carriers sent over Local Interconnection Trunks. Directory assistance, BLV/BLVI,



900, and 976 transiting calls from other exchange carriers and switched access calls are not included in the calculation of PLU.

- 1.63. "Point Of Interconnection (POI)" is a mutually agreed upon point of demarcation where the networks of Sprint and CLEC interconnect for the exchange of traffic.
- 1.64. "Proprietary Information" shall have the same meaning as Confidential Information.
- 1.65. "Rate Center" means the geographic point and corresponding geographic area which are associated with one or more particular NPA-NXX codes which have been assigned to Sprint or CLEC for its provision of Basic Exchange Telecommunications Services. The "rate center point" is the finite geographic point identified by a specific V&H coordinate, which is used to measure distance-sensitive end user traffic to/from the particular NPA-NXX designations associated with the specific Rate Center. The "rate center area" is the exclusive geographic area identified as the area within which Sprint or CLEC will provide Basic Exchange Telecommunications Services bearing the particular NPA-NXX designations associated with the specific Rate Center. The Rate Center point must be located within the Rate Center area.
- 1.66. "Routing Point" means a location which Sprint or CLEC has designated on its own network as the homing (routing) point for traffic inbound to Basic Exchange Services provided by Sprint or CLEC which bear a certain NPA-NXX designation. The Routing Point is employed to calculate mileage measurements for the distance-sensitive transport element charges of Switched Access Services. Pursuant to Telcordia Practice BR 795-100-100, the Routing Point may be an "End Office" location, or a "LEC Consortium Point of Interconnection." Pursuant to that same Telcordia Practice, examples of the latter shall be designated by a common language location identifier (CLLI) code with (x)MD or X(x) in positions 9, 10, 11, where (x) may be any alphanumeric A-Z or 0-9. The above referenced Telcordia document refers to the Routing Point as the Rating Point. The Rating Point/Routing Point need not be the same as the Rate Center Point, nor must it be located within the Rate Center Area, but must be in the same LATA as the NPA-NXX.
- 1.67. "Small Exchange Carrier Access Billing (SECAB)" means the document prepared by the Billing Committee of the OBF. The SECAB document, published by ATIS as Special Report SR OPT-001856, contains the recommended guidelines for the billing of access and other connectivity services.
- 1.68. "Selective Routing" is a service which automatically routes an E911 call to the PSAP that has jurisdictional responsibility for the service address of the telephone that dialed 911, irrespective of telephone company exchange or wire center boundaries.
- 1.69. "Signaling Transfer Point (STP)" means a signaling point that performs message routing functions and provides information for the routing of messages between

signaling points within or between CCIS networks. A STP transmits, receives and processes CCIS messages.

- 1.70. "Street Index Guide (SIG)" is a database defining the geographic area of an E911 service. It includes an alphabetical list of the street names, high-low house number ranges, community names, and Emergency Service Numbers provided by the counties or their agents to Sprint.
- 1.71. "Switch" means a Central Office Switch as defined in this Part A.
- 1.72. "Synchronous Optical Network (SONET)" is an optical interface standard that allows interworking of transmission products from multiple vendors (i.e., mid-span meets). The base rate is 51.84 MHps (OC-1/STS-1 and higher rates are direct multiples of the base rate up to 1.22 GHps).
- 1.73. "Tandem Office Switches", "Tandem", and "Tandem Switching" describe Class 4 switches which are used to connect and switch trunk circuits between and among end office switches and other tandems.
- 1.74. "Tariff" means a filing made at the state or federal level for the provision of a telecommunications service by a telecommunications carrier that provides for the terms, conditions and pricing of that service. Such filing may be required or voluntary and may or may not be specifically approved by the Commission or FCC.
- 1.75. "Technically Feasible" refers solely to technical or operational concerns, rather than economic, space, or site considerations.
- 1.76. "Telecommunications" is as defined in the Act.
- 1.77. "Telecommunications Carrier" is as defined in the Act.
- 1.78. "Telecommunication Services" is as defined in the Act.
- 1.79. "Transit Service" means the delivery of Local or non-Local Traffic by Sprint or CLEC, that originated on one Party's network, transited through the other Party's network, and terminated to a third party Telecommunications Carrier's network.
- 1.80. "Transit Traffic" means Local or non-Local traffic that originated on one Party's network, transited through the other Party's network, and terminated to a third party Telecommunications Carrier's network.
- 1.81. "Wholesale Service" means Telecommunication Services that Sprint provides at retail to subscribers who are not telecommunications carriers as set forth in 47 USC § 251(c)(4) which Sprint provides to resellers at a wholesale rate..
- 1.82. "Wire Center" denotes a building or space within a building which serves as an aggregation point on a given carrier's network, where transmission facilities and circuits are connected or switched. Wire center can also denote a building in which one or more central offices, used for the provision of Basic Exchange

Services and access services, are located. However, for purposes of EIC service, Wire Center shall mean those points eligible for such connections as specified in the FCC Docket No. 91-141, and rules adopted pursuant thereto.

- 1.83. "xDSL" refers to a generic term for a new series of high speed transmission protocols, equipment, and services designed to operate over copper wire. This series includes but is not limited to ADSL, VDSL, SDSL, and others.

## **PART B – GENERAL TERMS AND CONDITIONS**

### **2. SCOPE OF THIS AGREEMENT**

- 2.1. This Agreement, including Parts A through J, specifies the rights and obligations of each party with respect to the establishment, purchase, and sale of Local Interconnection, resale of Telecommunications Services and Unbundled Network Elements. Certain terms used in this Agreement shall have the meanings defined in PART A -- DEFINITIONS, or as otherwise elsewhere defined throughout this Agreement. Other terms used but not defined herein will have the meanings ascribed to them in the Act, in the FCC's, and in the Commission's Rules and Regulations. PART B sets forth the general terms and conditions governing this Agreement. The remaining Parts set forth, among other things, descriptions of the services, pricing, technical and business requirements, and physical and network security requirements.
- 2.2. Sprint may discontinue any interconnection arrangement, Telecommunications Service, or Network Element provided or required hereunder after providing CLEC reasonable notice as required by law. Sprint agrees to cooperate with CLEC and/or the appropriate regulatory body in any transition resulting from such discontinuation of service and to minimize the impact to customers which may result from such discontinuance of service.
- 2.3. Sprint shall provide notice of network changes and upgrades in accordance with §§ 51.325 through 51.335 of Title 47 of the Code of Federal Regulations.

### **3. REGULATORY APPROVALS**

- 3.1. This Agreement, and any amendment or modification hereof, will be submitted to the Commission for approval in accordance with § 252 of the Act within thirty (30) days after obtaining the last required Agreement signature. Sprint and CLEC shall use their best efforts to obtain approval of this Agreement by any regulatory body having jurisdiction over this Agreement. In the event any governmental authority or agency rejects any provision hereof, the Parties shall negotiate promptly and in good faith such revisions as may reasonably be required to achieve approval.
- 3.2. The Parties acknowledge that the respective rights and obligations of each Party as set forth in this Agreement are based on the texts of the Act and the rules and regulations promulgated thereunder by the FCC and the Commission as of the Effective Date ("Applicable Rules"). In the event of any amendment of the Act, any effective legislative action or any effective regulatory or judicial order, rule, regulation, arbitration award, dispute resolution procedures under this Agreement or other legal action purporting to apply the provisions of the Act to the Parties or in which the court, FCC or the Commission makes a generic determination that is generally applicable which revises, modifies or reverses the Applicable Rules (individually and collectively, "Amended Rules"), either Party may, by providing

written notice to the other Party, require that the affected provisions of this Agreement be renegotiated in good faith and this Agreement shall be amended accordingly to reflect the pricing, terms and conditions of each such Amended Rules relating to any of the provisions in this Agreement.

- 3.3. Notwithstanding any other provision of this Agreement to the contrary § 2.2 hereof shall control. Any rates, terms or conditions thus developed or modified shall be substituted in place of those previously in effect and shall be deemed to have been effective under this Agreement as of the effective date established by the Amended Rules, whether such action was commenced before or after the Effective Date of this Agreement. Should the Parties be unable to reach agreement with respect to the applicability of such order or the resulting appropriate modifications to this Agreement, either party may invoke the Dispute Resolution provisions of this Agreement, it being the intent of the parties that this Agreement shall be brought into conformity with the then current obligations under the Act as determined by the amended rules.

#### **4. TERM AND TERMINATION**

- 4.1. This Agreement shall be deemed effective upon the Effective Date, provided however that if CLEC has any outstanding past due obligations to Sprint, this Agreement will not be effective until such time as any past due obligations with Sprint are paid in full. No order or request for services under this Agreement shall be processed before the Effective Date, except as may otherwise be agreed in writing between the Parties, provided CLEC has established a customer account with Sprint and has completed the Implementation Plan described in Article 32 hereof.
- 4.2. Except as provided herein, Sprint and CLEC agree to provide service to each other on the terms of this Agreement for a period from the Effective Date through and including April 11, 2002 (the "End Date").
- 4.3. In the event of either Party's material breach of any of the terms or conditions hereof, including the failure to make any undisputed payment when due, the non-defaulting Party may immediately terminate this Agreement in whole or in part provided that the non-defaulting Party so advises the defaulting Party in writing of the event of the alleged default and the defaulting Party does not remedy the alleged default within sixty (60) days after written notice thereof.
- 4.4. Termination of this Agreement for any cause shall not release either Party from any liability which at the time of termination has already accrued to the other Party or which thereafter may accrue in respect to any act or omission prior to termination or from any obligation which is expressly stated herein to survive termination.
- 4.5. Notwithstanding the above, should Sprint sell or trade substantially all the assets in an exchange or group of exchanges that Sprint uses to provide

Telecommunications Services, then Sprint may terminate this Agreement in whole or in part as to that particular exchange or group of exchanges upon sixty (60) days prior written notice.

## **5. POST EXPIRATION INTERIM SERVICE ARRANGEMENTS**

5.1. In the event that this Agreement expires under §4.2, it is the intent of the Parties to provide in this Section for post-expiration interim service arrangements between the Parties so that service to their respective end users will not be interrupted should a new agreement not be consummated prior to the End Date. Therefore, except in the case of termination as a result of either Party's default under §4.3, or for termination upon sale under §4.5, Interconnection services that had been available under this Agreement and exist as of the End Date may continue uninterrupted after the End Date at the written request of either Party only under the terms of:

5.1.1. a new agreement voluntarily entered into by the Parties, pending approval by the Commission; or

5.1.2. such standard terms and conditions or tariffs approved by and made generally available by the Commission, if they exist at the time of expiration; or

5.1.3. an existing agreement between Sprint and another carrier, adopted by CLEC for the remaining term of that agreement. If neither §5.1.1 nor 5.1.2 are in effect, and CLEC fails to designate an agreement under this subsection, then Sprint may designate such agreement.

5.2. In the event that this Agreement expires under §4.2, and at the time of expiration, the Parties are actually in arbitration or mediation before the appropriate Commission or FCC under §252 of the Act, then at the request of either Party, the Parties shall provide each other Interconnection services after the End Date under the same terms as the expired Agreement. Service under these terms will continue in effect only until the earlier to occur of (i) one year from the End Date, or (ii) the issuance of an order, whether a final non-appealable order or not, by the Commission or FCC, approving an agreement resulting from the resolution of the issues set forth in such arbitration request.

## **6. CHARGES AND PAYMENT**

6.1. In consideration of the services provided by Sprint under this Agreement, CLEC shall pay the charges set forth in Part C subject to the provisions of §§ 3.2 and 3.3 hereof. The billing and payment procedures for charges incurred by CLEC hereunder are set forth in Part J.

6.2. In addition to any other applicable charges under this Article 6 and Part C, if CLEC purchases unbundled Local Switching elements, CLEC shall pay Sprint for intrastate toll minutes of use traversing such unbundled Local Switching elements,

intrastate carrier common line and interconnection charges as outlined on Part C hereto and any explicit intrastate universal service mechanism based on access charges.

- 6.3. Subject to the terms of this Agreement, the Parties shall pay invoices by the due date shown on the invoice. For invoices not paid when due, late payment charges will be assessed under § 6.5. If the payment due date is a Saturday, Sunday or a designated bank holiday, payment shall be made the next business day.
- 6.4. Billed amounts for which written, itemized disputes or claims have been filed are not due for payment until such disputes or claims have been resolved in accordance with the provisions governing dispute resolution of this Agreement. Itemized, written disputes must be filed with Sprint's National Exchange Access Center ("NEAC") no later than the due date of the related invoice. A copy of the dispute must be sent with the remittance of the remainder of the invoice.
- 6.5. Sprint will assess late payment charges to CLEC equal to the lesser of one and one-half percent (1.5%) per month or the maximum rate allowed by law for commercial transactions, of the balance due, until the amount due is paid in full.

## **7. AUDITS AND EXAMINATIONS**

- 7.1. As used herein "Audit" shall mean a comprehensive review of services performed under this Agreement; "Examination" shall mean an inquiry into a specific element of or process related to services performed under this Agreement billed amounts. Either party (the "Requesting Party") may perform one (1) Audit per twelve (12) month period commencing with the Effective Date. The Audit period will include no more than the preceding twelve (12) month period as of the date of the Audit request. The Requesting Party may perform Examinations as it deems necessary, with the assistance of the other Party, which will not be unreasonably withheld.
- 7.2. Upon thirty (30) days written notice by the Requesting Party to Audited Party, Requesting Party shall have the right through its authorized representative to make an Audit or Examination, during normal business hours, of any records, accounts and processes which contain information bearing upon the provision of the services provided and performance standards agreed to under this Agreement. Within the above-described thirty (30) day period, the Parties shall reasonably agree upon the scope of the Audit or Examination, the documents and processes to be reviewed, and the time, place and manner in which the Audit or Examination shall be performed. Audited Party agrees to provide Audit or Examination support, including appropriate access to and use of Audited Party's facilities (e.g.: conference rooms, telephones, copying machines).
- 7.3. Each party shall bear its own expenses in connection with the conduct of the Audit or Examination. The reasonable cost of special data extraction required by the Requesting Party to conduct the Audit or Examination will be paid for by the

Requesting Party. For purposes of this § 7.3, a "Special Data Extraction" shall mean the creation of an output record or informational report (from existing data files) that is not created in the normal course of business. If any program is developed to Requesting Party's specifications and at Requesting Party's expense, Requesting Party shall specify at the time of request whether the program is to be retained by Audited party for reuse for any subsequent Audit or Examination.

- 7.4. Adjustments based on the audit findings may be applied to the twelve (12) month period included in the audit. Adjustments, credits or payments shall be made and any corrective action shall commence within thirty (30) days from receipt of requesting Party's receipt of the final audit report to compensate for any errors or omissions which are disclosed by such Audit or Examination and are agreed to by the Parties. Interest shall be calculated in accordance with § 6.5 above.
- 7.5. Neither such right to examine and audit nor the right to receive an adjustment shall be affected by any statement to the contrary appearing on checks or otherwise, unless such statement expressly waiving such right appears in writing, is signed by the authorized representative of the party having such right and is delivered to the other party in a manner sanctioned by this Agreement.
- 7.6. This Article 7 shall survive expiration or termination of this Agreement for a period of one (1) year after expiration or termination of this Agreement.

## **8. INTELLECTUAL PROPERTY RIGHTS**

- 8.1. Any intellectual property which originates from or is developed by a Party shall remain in the exclusive ownership of that Party. Except for a limited license to use patents or copyrights to the extent necessary for the Parties to use any facilities or equipment (including software) or to receive any service solely as provided under this Agreement, no license in patent, copyright, trademark or trade secret, or other proprietary or intellectual property right now or hereafter owned, controlled or licensable by a Party, is granted to the other Party or shall be implied or arise by estoppel.
- 8.2. Neither Party shall have any obligation to defend, indemnify or hold harmless, or acquire any license or right for the benefit of, or owe any other obligation or any liability to, the other Party based on or arising from any claim, demand, or proceeding by any third party alleging or asserting that the use of any circuit, apparatus or system, or the use of any software, or the performance of any service or method, or the provision or use of any facilities by either party under this Agreement, constitutes direct or contributory infringement, or misuse or misappropriation of any patent, copyright, trademark, trade secret, or any other proprietary or intellectual property right of any third party.
- 8.3. Following notice of an infringement claim against Sprint based on the use by CLEC of a service or facility, CLEC shall at CLEC's expense, procure from the appropriate third parties the right to continue to use the alleged infringing



intellectual property or if CLEC fails to do so, Sprint may charge CLEC for such costs as permitted under a Commission order.

**9. LIMITATION OF LIABILITY**

- 9.1. Except as otherwise set forth in this Agreement, neither Party shall be responsible to the other for any indirect, special, consequential or punitive damages, including (without limitation) damages for loss of anticipated profits or revenue or other economic loss in connection with or arising from anything said, omitted, or done hereunder (collectively "Consequential Damages"), whether arising in contract or tort, provided that the foregoing shall not limit a Party's obligation under Article 10 to indemnify, defend, and hold the other party harmless against amounts payable to third parties. Notwithstanding the foregoing, in no event shall Sprint's liability to CLEC for a service outage exceed an amount equal to the proportionate charge for the service(s) or unbundled element(s) provided for the period during which the service was affected.

## 10. INDEMNIFICATION

- 10.1. Each Party agrees to indemnify and hold harmless the other Party from and against claims by third parties for damage to tangible personal or real property and/or personal injuries to the extent caused by the negligence or willful misconduct or omission of the indemnifying Party.
- 10.2. CLEC shall indemnify and hold harmless Sprint from all claims by CLEC's subscribers.
- 10.3. Sprint shall indemnify and hold harmless CLEC from all claims by Sprint's subscribers.
- 10.4. The indemnifying Party under this Article agrees to defend any suit brought against the other Party either individually or jointly with the indemnified Party for any such loss, injury, liability, claim or demand.
- 10.5. The indemnified Party agrees to notify the other Party promptly, in writing, of any written claims, lawsuits, or demands for which it is claimed that the indemnifying Party is responsible under this Article and to cooperate in every reasonable way to facilitate defense or settlement of claims.
- 10.6. The indemnifying Party shall have complete control over defense of the case and over the terms of any proposed settlement or compromise thereof. The indemnifying Party shall not be liable under this Article for settlement by the indemnified Party of any claim, lawsuit, or demand, if the indemnifying Party has not approved the settlement in advance, unless the indemnifying Party has had the defense of the claim, lawsuit, or demand tendered to it in writing and has failed to promptly assume such defense. In the event of such failure to assume defense, the indemnifying Party shall be liable for any reasonable settlement made by the indemnified Party without approval of the indemnifying Party.
- 10.7. When the lines or services of other companies and CLECs are used in establishing connections to and/or from points not reached by a Party's lines, neither Party shall be liable for any act or omission of the other companies or carriers.
- 10.8. In addition to its indemnity obligations hereunder, each Party shall, to the extent allowed by law or Commission Order, provide, in its tariffs and contracts with its subscribers that relate to any Telecommunications Services provided or contemplated under this Agreement, that in no case shall such Party or any of its agents, contractors or others retained by such Party be liable to any subscriber or third party for
  - 10.8.1. any loss relating to or arising out of this Agreement, whether in contract or tort, that exceeds the amount such Party would have charged the applicable subscriber for the service(s) or function(s) that gave rise to such loss, and
  - 10.8.2. Consequential Damages (as defined in Article 9 above).

## **11. BRANDING**

- 11.1. CLEC shall provide the exclusive interface to CLEC subscribers, except as CLEC shall otherwise specify for the reporting of trouble or other matters identified by CLEC for which Sprint may directly communicate with CLEC subscribers. In those instances where CLEC requests that Sprint personnel interface with CLEC subscribers, such Sprint personnel shall inform the CLEC subscribers that they are representing CLEC, or such brand as CLEC may specify.
- 11.2. Other business materials furnished by Sprint to CLEC subscribers shall bear no corporate name, logo, trademark or tradename.
- 11.3. Except as specifically permitted by a Party, in no event shall either Party provide information to the other Party's subscribers about the other Party or the other Party's products or services.
- 11.4. Sprint shall share pertinent details of Sprint's training approaches related to branding with CLEC to be used by Sprint to assure that Sprint meets the branding requirements agreed to by the Parties.
- 11.5. This Article 11 shall not confer on either Party any rights to the service marks, trademarks and/or trade names owned by or used in connection with services by the other Party, except as expressly permitted in writing by the other Party.

## **12. REMEDIES**

- 12.1. Except as otherwise provided herein, all rights of termination, cancellation or other remedies prescribed in this Agreement, or otherwise available, are cumulative and are not intended to be exclusive of other remedies to which the injured Party may be entitled in case of any breach or threatened breach by the other Party of any provision of this Agreement, and use of one or more remedies shall not bar use of any other remedy for the purpose of enforcing the provisions of this Agreement.

## **13. CONFIDENTIALITY AND PUBLICITY**

- 13.1. All information which is disclosed by one party ("Disclosing Party") to the other ("Recipient") in connection with this Agreement, or acquired in the course of performance of this Agreement, shall be deemed confidential and proprietary to the Disclosing Party and subject to this Agreement, such information including but not limited to, orders for services, usage information in any form, and CPNI as that term is defined by the Act and the rules and regulations of the FCC ("Confidential and/or Proprietary Information").
- 13.2. During the term of this Agreement, and for a period of one (1) year thereafter, Recipient shall

- 13.2.1. use it only for the purpose of performing under this Agreement,
  - 13.2.2. hold it in confidence and disclose it only to employees or agents who have a need to know it in order to perform under this Agreement, and
  - 13.2.3. safeguard it from unauthorized use or Disclosure using no less than the degree of care with which Recipient safeguards its own Confidential Information.
- 13.3. Recipient shall have no obligation to safeguard Confidential Information
- 13.3.1. which was in the Recipient's possession free of restriction prior to its receipt from Disclosing Party,
  - 13.3.2. which becomes publicly known or available through no breach of this Agreement by Recipient,
  - 13.3.3. which is rightfully acquired by Recipient free of restrictions on its Disclosure, or
  - 13.3.4. which is independently developed by personnel of Recipient to whom the Disclosing Party's Confidential Information had not been previously disclosed.
- 13.4. Recipient may disclose Confidential Information if required by law, a court, or governmental agency, provided that Disclosing Party has been notified of the requirement promptly after Recipient becomes aware of the requirement, and provided that Recipient undertakes all lawful measures to avoid disclosing such information until Disclosing Party has had reasonable time to obtain a protective order. Recipient agrees to comply with any protective order that covers the Confidential Information to be disclosed.
- 13.5. Each Party agrees that in the event of a breach of this Article 13 by Recipient or its representatives, Disclosing Party shall be entitled to equitable relief, including injunctive relief and specific performance. Such remedies shall not be exclusive, but shall be in addition to all other remedies available at law or in equity.
- 13.6. Unless otherwise agreed, neither Party shall publish or use the other Party's logo, trademark, service mark, name, language, pictures, symbols or words from which the other Party's name may reasonably be inferred or implied in any product, service, advertisement, promotion, or any other publicity matter, except that nothing in this paragraph shall prohibit a Party from engaging in valid comparative advertising. This § 13.5 shall confer no rights on a Party to the service marks, trademarks and trade names owned or used in connection with services by the other Party or its Affiliates, except as expressly permitted by the other Party.
- 13.7. Neither Party shall produce, publish, or distribute any press release nor other publicity referring to the other Party or its Affiliates, or referring to this

Agreement, without the prior written approval of the other Party. Each party shall obtain the other Party's prior approval before discussing this Agreement in any press or media interviews. In no event shall either Party mischaracterize the contents of this Agreement in any public statement or in any representation to a governmental entity or member thereof.

- 13.8. Except as otherwise expressly provided in this Article 13, nothing herein shall be construed as limiting the rights of either Party with respect to its customer information under any applicable law, including without limitation § 222 of the Act.

#### **14. DISCLAIMER OF WARRANTIES**

- 14.1. EXCEPT AS SPECIFICALLY PROVIDED ELSEWHERE IN THIS AGREEMENT TO THE CONTRARY, NEITHER PARTY MAKES ANY REPRESENTATIONS OR WARRANTIES, EXPRESS OR IMPLIED, WITH RESPECT TO QUALITY, FUNCTIONALITY OR CHARACTERISTICS OF THE SERVICES PROVIDED PURSUANT TO THIS AGREEMENT, INCLUDING, BUT NOT LIMITED TO, IMPLIED WARRANTIES OF MERCHANTABILITY AND/OR FITNESS FOR A PARTICULAR PURPOSE. NO REPRESENTATION OR STATEMENT MADE BY EITHER PARTY OR ANY OF ITS AGENTS OR EMPLOYEES, ORAL OR WRITTEN, INCLUDING, BUT NOT LIMITED TO, ANY SPECIFICATIONS, DESCRIPTIONS OR STATEMENTS PROVIDED OR MADE SHALL BE BINDING UPON EITHER PARTY AS A WARRANTY.

#### **15. ASSIGNMENT AND SUBCONTRACT**

- 15.1. If any Affiliate of either Party succeeds to that portion of the business of such Party that is responsible for, or entitled to, any rights, obligations, duties, or other interests under this Agreement, such Affiliate may succeed to those rights, obligations, duties, and interest of such Party under this Agreement. In the event of any such succession hereunder, the successor shall expressly undertake in writing to the other Party the performance and liability for those obligations and duties as to which it is succeeding a Party to this Agreement. Thereafter, the successor Party shall be deemed Carrier or Sprint and the original Party shall be relieved of such obligations and duties, except for matters arising out of events occurring prior to the date of such undertaking.
- 15.2. Except as provided in § 15.1, any assignment of this Agreement or of the work to be performed, in whole or in part, or of any other interest of a Party hereunder, without the other Party's written consent, which consent shall not be unreasonably withheld or delayed, shall be void.

#### **16. GOVERNING LAW**

- 16.1. This Agreement shall be governed by and construed in accordance with the Act,

the FCC's Rules and Regulations and orders of the Commission, except insofar as state law may control any aspect of this Agreement, in which case the domestic laws of the Commission's state, without regard to its conflicts of laws principles, shall govern.

**17. RELATIONSHIP OF PARTIES**

17.1. It is the intention of the Parties that each Party shall be an independent contractor and nothing contained herein shall constitute the Parties as joint venturers, partners, employees or agents of one another, and neither Party shall have the right or power to bind or obligate the other.

**18. NO THIRD PARTY BENEFICIARIES**

18.1. The provisions of this Agreement are for the benefit of the Parties hereto and not for any other person, and this Agreement shall not provide any person not a party hereto with any remedy, claim, liability, reimbursement, right of action, or other right in excess of those existing without reference hereto. This shall not be construed to prevent Carrier from providing its Telecommunications Services to other carriers.

**19. NOTICES**

19.1. Except as otherwise provided herein, all notices or other communication hereunder shall be deemed to have been duly given when made in writing and delivered in person or deposited in the United States mail, certified mail, postage prepaid, return receipt requested and addressed as follows:

If to Sprint:

Director  
Local Carrier Markets  
Sprint  
6480 Sprint Parkway  
Mailstop KSOPHM0310-  
3A453  
Overland Park, KS 66251

If to

CLEC:

Kenneth D. Allen  
100 W. Lucerne Circle, Ste. 600  
Orlando, FL 32801

19.2. If delivery, other than certified mail, return receipt requested, is used to give notice, a receipt of such delivery shall be obtained and the notice shall be effective when received. If delivery via certified mail, return receipt requested, is used,

notice shall be effective when sent. The address to which notices or communications may be given to either Party may be changed by written notice given by such Party to the other pursuant to this Article 19.

## **20. WAIVERS**

- 20.1. No waiver of any provisions of this Agreement and no consent to any default under this Agreement shall be effective unless the same shall be in writing and properly executed by or on behalf of the Party against whom such waiver or consent is claimed.
- 20.2. No course of dealing or failure of any Party to strictly enforce any term, right, or condition of this Agreement in any instance shall be construed as a general waiver or relinquishment of such term, right or condition.
- 20.3. Waiver by either party of any default by the other Party shall not be deemed a waiver of any other default.

## **21. SURVIVAL**

- 21.1. Termination of this Agreement, or any part hereof, for any cause shall not release either Party from any liability which at the time of termination had already accrued to the other Party or which thereafter accrues in any respect to any act or omission occurring prior to the termination or from an obligation which is expressly stated in this Agreement to survive termination including but not limited to §§ 6, 7, 8, 9, 10, 13, 18, 20, and 23.

## **22. FORCE MAJEURE**

- 22.1. Neither Party shall be held liable for any delay or failure in performance of any part of this Agreement from any cause beyond its control and without its fault or negligence, such as acts of God, acts of civil or military authority, embargoes, epidemics, war, terrorist acts, riots, insurrections, fires, explosions, earthquakes, nuclear accidents, floods, power blackouts, strikes, work stoppage affecting a supplier or unusually severe weather. No delay or other failure to perform shall be excused pursuant to this Article 22 unless delay or failure and consequences thereof are beyond the control and without the fault or negligence of the Party claiming excusable delay or other failure to perform. Subject to Article 4 hereof, in the event of any such excused delay in the performance of a Party's obligation(s) under this Agreement, the due date for the performance of the original obligation(s) shall be extended by a term equal to the time lost by reason of the delay. In the event of such delay, the delayed Party shall perform its obligations at a performance level no less than that which it uses for its own operations. In the event of such performance delay or failure by Sprint, Sprint agrees to resume performance in a nondiscriminatory manner and not favor its own provision of Telecommunications Services above that of CLEC.

## **23. DISPUTE RESOLUTION**

- 23.1. The Parties recognize and agree that the Commission has continuing jurisdiction to implement and enforce all terms and conditions of this Agreement. Accordingly, the Parties agree that any dispute arising out of or relating to this Agreement that the Parties themselves cannot resolve may be submitted to the Commission for resolution. The Parties agree to seek expedited resolution by the Commission, and shall request that resolution occur in no event later than sixty (60) days from the date of submission of such dispute. If the Commission appoints an expert(s) or other facilitator(s) to assist in its decision making, each party shall pay half of the fees and expenses so incurred. During the Commission proceeding each Party shall continue to perform its obligations under this Agreement provided, however, that neither Party shall be required to act in any unlawful fashion. This provision shall not preclude the Parties from seeking relief available in any other forum.
- 23.2. If any matter is subject to a bona fide dispute between the Parties, the disputing Party shall within thirty (30) days of the event giving rise to the dispute, give written notice to the other Party of the dispute and include in such notice the specific details and reasons for disputing each item.
- 23.3. If the Parties are unable to resolve the issues related to the dispute in the normal course of business within thirty (30) days after delivery of notice of the Dispute, to the other Party, the dispute shall be escalated to a designated representative who has authority to settle the dispute and who is at a higher level of management than the persons with direct responsibility for administration of this Agreement. The designated representatives shall meet as often as they reasonably deem necessary in order to discuss the dispute and negotiate in good faith in an effort to resolve such dispute, but in no event shall such resolution exceed 60 days from the initial notice. The specific format for such discussions will be left to the discretion of the designated representatives, provided, however, that all reasonable requests for relevant information made by one Party to the other Party shall be honored.
- 23.4. After such period either Party may file a complaint with the FCC or the Commission.

## **24. COOPERATION ON FRAUD**

- 24.1. The Parties agree that they shall cooperate with one another to investigate, minimize and take corrective action in cases of fraud. The Parties' fraud minimization procedures are to be cost effective and implemented so as not to unduly burden or harm one party as compared to the other.

## **25. TAXES**

- 25.1. Any Federal, state or local excise, license, sales, use, or other taxes or tax-like



charges (excluding any taxes levied on income) resulting from the performance of this Agreement shall be borne by the Party upon which the obligation for payment is imposed under applicable law, even if the obligation to collect and remit such taxes is placed upon the other Party. Any such taxes shall be shown as separate items on applicable billing documents between the Parties. The Party obligated to collect and remit taxes shall do so unless the other Party provides such Party with the required evidence of exemption. The Party so obligated to pay any such taxes may contest the same in good faith, at its own expense, and shall be entitled to the benefit of any refund or recovery, provided that such party shall not permit any lien to exist on any asset of the other party by reason of the contest. The Party obligated to collect and remit taxes shall cooperate fully in any such contest by the other Party by providing records, testimony and such additional information or assistance as may reasonably be necessary to pursue the contest.

**26. AMENDMENTS AND MODIFICATIONS**

26.1. No provision of this Agreement shall be deemed waived, amended or modified by either party unless such a waiver, amendment or modification is in writing, dated, and signed by both Parties.

**27. SEVERABILITY**

27.1. Subject to § 3.2, if any part of this Agreement is held to be invalid for any reason, such invalidity will affect only the portion of this Agreement which is invalid. In all other respects this Agreement will stand as if such invalid provision had not been a part thereof, and the remainder of the Agreement shall remain in full force and effect.

**28. HEADINGS NOT CONTROLLING**

28.1. The headings and numbering of Articles, Sections, Parts and Parts in this Agreement are for convenience only and shall not be construed to define or limit any of the terms herein or affect the meaning or interpretation of this Agreement.

**29. ENTIRE AGREEMENT**

29.1. This Agreement, including all Parts and Parts and subordinate documents attached hereto or referenced herein, all of which are hereby incorporated by reference herein, constitute the entire matter thereof, and supersede all prior oral or written agreements, representations, statements, negotiations, understandings, proposals, and undertakings with respect to the subject matter thereof.

**30. COUNTERPARTS**

30.1. This Agreement may be executed in counterparts. Each counterpart shall be considered an original and such counterparts shall together constitute one and the same instrument.

## **31. SUCCESSORS AND ASSIGNS**

- 31.1. This Agreement shall be binding upon, and inure to the benefit of, the Parties hereto and their respective successors and permitted assigns.

## **32. IMPLEMENTATION PLAN**

- 32.1. This Agreement sets forth the overall standards of performance for services, processes, and systems capabilities that the Parties will provide to each other, and the intervals at which those services, processes and capabilities will be provided. The Parties understand that the arrangements and provision of services described in this Agreement shall require technical and operational coordination between the Parties. Accordingly, the Parties agree to form a team (the "Implementation Team") that shall develop and identify those processes, guidelines, specifications, standards and additional terms and conditions necessary to support the terms of this Agreement. Each Party shall designate, in writing, no more than four (4) persons to be permanent members of the Implementation Team; provided that either Party may include in meetings or activities such technical specialists or other individuals as may be reasonably required to address a specific task, matter or subject. Each Party may replace its representatives by delivering written notice thereof to the other Party.
- 32.2. The agreements reached by the Implementation Team shall be documented in an operations manual (the "Implementation Plan") within one hundred-twenty (120) days of both Parties having designated members of the Implementation Team. The Implementation Plan shall address the following matters, and may include any other matters agreed upon by the Implementation Team:
- 32.2.1. the respective duties and responsibilities of the Parties with respect to the administration and maintenance of the interconnections (including signaling) specified in Part 3 and the trunk groups specified in Part 4 and, including standards and procedures for notification and discoveries of trunk disconnects;
  - 32.2.2. disaster recovery and escalation provisions;
  - 32.2.3. access to Operations Support Systems functions provided hereunder, including gateways and interfaces;
  - 32.2.4. escalation procedures for ordering, provisioning, billing, and maintenance;
  - 32.2.5. single points of contact for ordering, provisioning, billing, and maintenance;
  - 32.2.6. service ordering and provisioning procedures, including provision of the trunks and facilities;
  - 32.2.7. provisioning and maintenance support;

- 32.2.8. conditioning and provisioning of collocation space and maintenance of Virtually Collocated equipment;
  - 32.2.9. procedures and processes for Directories and Directory Listings;
  - 32.2.10. billing processes and procedures;
  - 32.2.11. network planning components including time intervals;
  - 32.2.12. joint systems readiness and operational readiness plans;
  - 32.2.13. appropriate testing of services, equipment, facilities and Network Elements;
  - 32.2.14. monitoring of inter-company operational processes;
  - 32.2.15. procedures for coordination of local PIC changes and processing;
  - 32.2.16. physical and network security concerns;
  - 32.2.17. Completion of CLEC Checklist and supporting documentation to establish a billing account; and
  - 32.2.18. such other matters specifically referenced in this Agreement that are to be agreed upon by the Implementation Team and/or contained in the Implementation Plan.
- 32.3. The Implementation Plan may be amended from time to time by the Implementation Team, as the team deems appropriate. Unanimous written consent of the permanent members of the Implementation Team shall be required for any action of the Implementation Team. If the Implementation Team is unable to act, the existing provisions of the Implementation Plan shall remain in full force and effect.

### **33. FEDERAL JURISDICTIONAL AREAS**

- 33.1. CLEC understands and agrees that this agreement serves as actual notice that Sprint and its Affiliates have entered into a binding contract to provide exclusive telecommunications services for the Army and Air Force Exchange Service ("AAFES") during the term of this agreement. The AAFES contract specifies, among other things, that Sprint shall provide all telecommunications services to officer and enlisted temporary living facilities (commonly named Bachelor Officer Quarters and Bachelor Enlisted Quarters) on United States Army bases. Sprint will be entitled to refuse to resell telecommunications services where such sale would be contrary to the AAFES agreement. CLEC is entitled to communicate to any potential CLEC customer that CLEC is unable to provide the customer telecommunications services because of the AAFES agreement.

## **PART C GENERAL PRINCIPLES**

### **34. USE OF FACILITIES.**

34.1. In situations where the CLEC has the use of the facilities (i.e., local loop) to a specific customer premise, either through resale of local service or the lease of the local loop as an Unbundled Network Element, and Sprint receives a good faith request for service from a customer at the same premise, the following will apply:

34.1.1. Sprint shall notify the CLEC by phone through the designated CLEC contact and via fax that it has had a request for service at the premise location that is currently being served by the CLEC;

34.1.2. If available to Sprint, Sprint shall include the name and address of the party receiving service at such locations, but at a minimum shall provide local service address location information;

34.1.3. So long as Sprint follows the methods prescribed by the FCC for carrier change verification with the customer at the premises involved, Sprint shall be free to use the facilities in question upon the expiration of 24 hours following the initial phone notification from Sprint to CLEC and Sprint shall issue a disconnect order with respect to the CLEC service at that location.

### **35. PRICE SCHEDULE**

35.1. All prices under this agreement are set forth in Table One of this Part C.

35.2. Subject to the provisions of Part B, Article 3 of this Agreement, all rates provided under this Agreement shall remain in effect for the term of this Agreement.

### **36. LOCAL SERVICE RESALE**

36.1. The rates that CLEC shall pay to Sprint for Local Resale are as set forth in Table 1 of this Part and shall be applied consistent with the provisions of Part D of this Agreement.

### **37. INTERCONNECTION AND RECIPROCAL COMPENSATION**

37.1. The rates to be charged for the exchange of Local Traffic are set forth in Table 1 of this Part and shall be applied consistent with the provisions of Part F of this Agreement. Under this agreement, Sprint is only required to compensate CLEC for terminating Local Traffic.

37.2. Compensation for the termination of toll traffic and the origination of 800 traffic between the interconnecting parties shall be based on the applicable access charges in accordance with FCC and Commission Rules and Regulations and consistent with the provisions of Part F of this Agreement.

37.3. INP is available in all Sprint service areas where LNP is not available. Once LNP is available, all INP arrangements will be converted to LNP. Where INP is available and a toll call is completed through Sprint's INP arrangement (e.g., remote call forwarding) to CLEC's subscriber, CLEC shall be entitled to applicable access charges in accordance with the FCC and Commission Rules and Regulations. If a national standard billing method has not been developed for a CLEC to directly bill a carrier access for a toll call that has been completed using interim number portability, then the INP Rate specific to Access Settlements in this Part C will be used.

37.3.1. The ported party shall charge the porting party on a per line basis using the INP Rate specific to Access Settlements in lieu of any other compensation charges for terminating such traffic. The traffic that is not identified as subject to INP will be compensated as local interconnection as set forth in § 37.1.

37.3.2. CLEC shall pay a transit rate, comprised of the transport and tandem rate elements, as set forth in Table 1 of this Part when CLEC uses a Sprint access tandem to terminate a local call to a third party LEC or another CLEC. Sprint shall pay CLEC a transit rate equal to the Sprint rate referenced above when Sprint uses a CLEC switch to terminate a local call to a third party LEC or another CLEC.

37.4. CLEC will identify the Percent Local Usage (PLU) factor on each interconnection order to identify its "Local Traffic," as defined herein, for reciprocal compensation purposes. Sprint may request CLEC's traffic study documentation of the PLU at any time to verify the factor, and may compare the documentation to studies developed by Sprint. Should the documentation indicate that the factor should be changed by Sprint, the Parties agree that any changes will only be retroactive to traffic for the previous 90 days. For non-local traffic, the Parties agree to exchange traffic and compensate one another based on the rates and elements included in each party's access tariffs.

## **38. UNBUNDLED NETWORK ELEMENTS**

38.1. The charges that CLEC shall pay to Sprint for Unbundled Network Elements are set forth in Table 1 of this Part C.

**TABLE 1 - RATES**

PRICE SHEETS

38.2.

**RESALE DISCOUNTS**

Other than Operator/DA	19.40%
Op Assist/DA	12.10%

**USAGE FILE CHARGES:**

Message Provisioning, per message	\$0.005
Data Transmission, per message	\$0.002
Tape Charge, per tape	\$50.00

RATE ELEMENT	SOURCE	RECURRING RATE	NRC
Service Order NRC			\$25.15
Service Order Listing Only			\$20.82
Central Office Interconnection Charge			\$10.27
Trip Charge			\$18.41
Outside Plant Interconnection (2-W)			\$59.75
Outside Plant Interconnection (4-W)			\$74.72
NID Installation Charge			\$37.36
NID Connection Charge			\$18.68
Testing			\$1.42
Loop Rework Charge (2-W)			\$37.38
Loop Rework Charge (4-W)			\$62.41
Trouble Isolation and Testing			\$66.58
OSS Service Charge		\$1.77	
<b>Bona Fide Requests</b>			
Cancellation Charges			ICB
New Unbundled Network Element (s)		ICB	ICB
New Point(s) of Interconnection		ICB	ICB
<b>Authorization/Agency</b>			
<b>Presubscription, per telephone service line or trunk</b>			
To change intralata toll carrier or interlata carrier			\$4.80
<b>To change both intralata toll carrier and interlata carrier</b>			
if same carrier			\$4.80
- if different carriers			\$6.24
<b>Disputed Transfer</b>			
Per residence line or trunk			\$50.00
Per Business line or trunk			\$60.00
<b>NID</b>			
1 Line		\$0.79	See NRC Section
2 Line		\$0.95	See NRC Section

SmartJack		\$12.37	See NRC Section
LOOP			
Analog 2-wire	Band 1	\$10.78	See NRC Section
	Band 2	\$15.41	See NRC Section
	Band 3	\$20.54	See NRC Section
	Band 4	\$27.09	See NRC Section
	Band 5	\$39.66	See NRC Section
	Band 6	\$74.05	See NRC Section
Analog 4-wire	Band 1	\$18.80	See NRC Section
	Band 2	\$26.88	See NRC Section
	Band 3	\$35.85	See NRC Section
	Band 4	\$47.24	See NRC Section
	Band 5	\$69.17	See NRC Section
	Band 6	\$129.13	See NRC Section
DS0 2 Wire Digital Data Loop or Interconnection ADSL/ISDN-BRI			
	Band 1	\$11.65	\$89.14
	Band 2	\$16.65	\$89.14
	Band 3	\$22.20	\$89.14
	Band 4	\$29.26	\$89.14
	Band 5	\$42.84	\$89.14
	Band 6	\$79.98	\$89.14
DS0 4 Wire Digital Data Loop 56 or 64 kbps			
	Band 1	\$20.30	\$89.14
	Band 2	\$29.03	\$89.14
	Band 3	\$38.72	\$89.14
	Band 4	\$51.02	\$89.14
	Band 5	\$74.70	\$89.14
	Band 6	\$139.46	\$89.14
DS1 4 Wire Digital Data Loop DS1/T1/ISDN-PRI			
	Band 1	\$64.49	\$112.75
	Band 2	\$74.96	\$112.75
	Band 3	\$84.83	\$112.75
	Band 4	\$97.36	\$112.75
	Band 5	\$124.02	\$112.75
	Band 6	\$194.40	\$112.75
	DS3	ICB	
Local Switching			

Band 1		\$4.44	See NRC Section
Band 2		\$4.99	See NRC Section
Band 3		\$5.77	See NRC Section
Band 4		\$6.59	See NRC Section
Band 5		\$7.40	See NRC Section
Band 6		\$8.43	See NRC Section
ISDN		ICB	
CENTREX		ICB	
PBS		ICB	
DS1		ICB	
<b>FEATURES</b>			
CCF Package *		\$0.23	\$3.21
CLASS Package *		\$4.74	\$5.76
CENTREX Package *		\$10.47	\$36.66
- 3 Way Conf/Consult/Hold Transfer		\$1.80	\$21.12
- Conf Calling - 6 Way Station Control		\$2.35	\$31.00
- Dial Transfer to Tandem Tie Line		\$0.12	\$141.86
- Direct Connect		\$0.03	\$24.28
- Meet Me Conference		\$17.03	\$44.86
- Multi-Hunt Service		\$0.08	\$27.05
<b>INTERIM NUMBER PORTABILITY</b>			
RCF Residential	Commission Order	\$0.00	\$0.00
RCF Business	Commission Order	\$0.00	\$0.00
Call Path Residential	Commission Order	\$0.00	\$0.00
Call Path Business	Commission Order	\$0.00	\$0.00
	Should be tracking for potential recovery through permanent number portability.	Will be determined in Florida docket 950737-TP	
<b>INP RATES SPECIFIC TO ACCESS SETTLEMENTS</b>			
Per INP Line		\$5.89	
<b>TANDEM SWITCHING</b>			
		\$0.002085	
<b>TRANSPORT</b>			
DS1		See attached transport worksheet	\$222.95
DS3		See attached transport worksheet	\$249.16
Common		\$0.000711	N/A
<b>RECIPROCAL COMPENSATION</b>			
End Office		\$0.003671	NA
Tandem Switching		\$0.002085	NA



Transport			
DS1		Rate Varies	\$222.95
DS3		Rate Varies	\$249.16
Common		\$0.000711	N/A
<b>INTERCONNECTION</b>			
These rates apply when collocation is not involved. For collocation rates, see the appropriate tariff.			
DS0 Elec X-Conn (DS0 UNECC)		\$0.94	N/A
DS1 Elec X-Conn (DS1 UNECC)		\$2.93	N/A
DS3 Elec X-Conn (DS3 UNECC)		\$25.85	N/A
DS1 Facility Cross Connect: 1/2 of a DS1 UNECC consisting of one DSX panel and high frequency cable.		\$1.47	N/A
<b>COMMON CHANNEL SIGNALING</b>			
<b>INTERCONNECTION SERVICE</b>			
STP Port		\$422.40	\$308.00
STP Switching		\$0.76	N/A
STP Transport Link 56.0 Kpbs SS7 Link per month	IES Tariff	\$82.00	N/A
STP Transport Link 56.0 Kpbs SS7 Link per mile	IES Tariff	\$4.80	N/A
STP Transport Link 1.544 Mbps SS7 Link per month	IES Tariff	\$97.50	N/A
STP Transport Link 1.544 Mbps SS7 Link per mile	IES Tariff	\$20.00	N/A
Multiplexing DS1 to DS0	IES Tariff	\$300.00	\$142.00
Originating Point Code (OPC)	IES Tariff		\$22.30
GlobalTitle Address Translation (GTT)	IES Tariff		\$11.15
<b>LINE INFORMATION DATABASE</b>			
LIDB Database Transport per query	IES Tariff	\$0.0016	
LIDB Database per query	IES Tariff	\$0.0366	
Toll Free Code Access Service query	IES Tariff	\$0.008822	
Toll Free Code Optional Service query	IES Tariff	\$0.001405	
<b>DIRECTORY ASSISTANCE SERVICES</b>			
DA Database Listing & Update per listing or update		\$0.05	
DA Data Base Query Service per query		\$0.0100	
<b>TOLL &amp; LOCAL OPERATOR SERVICES</b>			
Toll and Local Assistance Service (Live)		\$0.414	
<b>DA OPERATOR SERVICE</b>			
DA Operator Service (Live)		\$0.353	
<b>911 TANDEM PORT</b>			
Per DSO Equivalent Port		\$15.81	\$187.50
<b>STREET INDEX GUIDE</b>			
Monthly Charge		\$41.00	
Tape Charge		\$50.00	
<b>OPERATIONAL SUPPORT SYSTEMS</b>			
OSS Interfaces		ICB	

--	--	--	--

**LOOPS**

Exchange	CLLI	Band	2 Wire Voice Grade Rate	4 Wire Voice Grade Rate	DS0 2 Wire Digital Data Loop or Interconnection ADSL/SDN-BRI	DS0 4 Wire Digital Data 56 or 64 kbps	DS1 4 Wire Digital Data DS1/T1/SDN-PRI Loop or Interconnection	DS3 Digital Data Loop or Interconnection
----------	------	------	----------------------------------	----------------------------------	---	--	---	---

Maitland XA	MTLDFLXA	1	\$10.78	\$ 18.80	\$ 11.65	\$ 20.30	\$ 64.49	ICB
Maitland TC	MTLDFLTC	1	\$10.78	\$ 18.80	\$ 11.65	\$ 20.30	\$ 64.49	ICB
Tallahassee - Calhoun	TLHSFLXA	1	\$10.78	\$ 18.80	\$ 11.65	\$ 20.30	\$ 64.49	ICB
Tallahassee - FSU	TLHSFLXE	1	\$10.78	\$ 18.80	\$ 11.65	\$ 20.30	\$ 64.49	ICB
Destin	DESTFLXA	1	\$10.78	\$ 18.80	\$ 11.65	\$ 20.30	\$ 64.49	ICB
South Fort Meyers	FTMYFLXC	1	\$10.78	\$ 18.80	\$ 11.65	\$ 20.30	\$ 64.49	ICB
Boca Grande	BCGRFLXA	1	\$10.78	\$ 18.80	\$ 11.65	\$ 20.30	\$ 64.49	ICB
Murdock	MRDCFLEXA	1	\$10.78	\$ 18.80	\$ 11.65	\$ 20.30	\$ 64.49	ICB
Fort Myers	FTMYFLXA	1	\$10.78	\$ 18.80	\$ 11.65	\$ 20.30	\$ 64.49	ICB
Winter Park	WNPFLXA	1	\$10.78	\$ 18.80	\$ 11.65	\$ 20.30	\$ 64.49	ICB
Fort Myers Beach	FTMBFLXA	1	\$10.78	\$ 18.80	\$ 11.65	\$ 20.30	\$ 64.49	ICB
Lake Brantley	LKBRFLXA	1	\$10.78	\$ 18.80	\$ 11.65	\$ 20.30	\$ 64.49	ICB
North Naples	NNPLFLXA	1	\$10.78	\$ 18.80	\$ 11.65	\$ 20.30	\$ 64.49	ICB
Naples Moorings	NPLSFLXD	1	\$10.78	\$ 18.80	\$ 11.65	\$ 20.30	\$ 64.49	ICB

Marco Island	MOISFLXA	2	\$15.41	\$ 26.88	\$ 16.65	\$ 29.03	\$ 74.96	ICB
Altamonte Springs	ALSPFLXA	2	\$15.41	\$ 26.88	\$ 16.65	\$ 29.03	\$ 74.96	ICB
Iona	IONAFLXA	2	\$15.41	\$ 26.88	\$ 16.65	\$ 29.03	\$ 74.96	ICB
Goldenrod	GLRDFLXA	2	\$15.41	\$ 26.88	\$ 16.65	\$ 29.03	\$ 74.96	ICB
Fort Walton Beach XB	FTWBFLXB	2	\$15.41	\$ 26.88	\$ 16.65	\$ 29.03	\$ 74.96	ICB
Fort Walton Beach XA	FTWBFLXA	2	\$15.41	\$ 26.88	\$ 16.65	\$ 29.03	\$ 74.96	ICB
Buenaventura Lakes	KSSMFLXD	2	\$15.41	\$ 26.88	\$ 16.65	\$ 29.03	\$ 74.96	ICB
Tallahassee - Willis	TLHSFLXB	2	\$15.41	\$ 26.88	\$ 16.65	\$ 29.03	\$ 74.96	ICB
Shalimar	SHLMFLXA	2	\$15.41	\$ 26.88	\$ 16.65	\$ 29.03	\$ 74.96	ICB
Cypress Lake XA	CYLKFLXA	2	\$15.41	\$ 26.88	\$ 16.65	\$ 29.03	\$ 74.96	ICB
Casselberry	CSLBFLXA	2	\$15.41	\$ 26.88	\$ 16.65	\$ 29.03	\$ 74.96	ICB
Fort Walton Beach XC	FTWBFLXC	2	\$15.41	\$ 26.88	\$ 16.65	\$ 29.03	\$ 74.96	ICB
Cypress Lake XB	CYLKFLXB	2	\$15.41	\$ 26.88	\$ 16.65	\$ 29.03	\$ 74.96	ICB
Orange City	ORCYFLXA	2	\$15.41	\$ 26.88	\$ 16.65	\$ 29.03	\$ 74.96	ICB
Ocala XJ	OCALFLXJ	2	\$15.41	\$ 26.88	\$ 16.65	\$ 29.03	\$ 74.96	ICB
North Fort Myers XA	NFMYFLXA	2	\$15.41	\$ 26.88	\$ 16.65	\$ 29.03	\$ 74.96	ICB
Cape Coral	CPCRFLXA	2	\$15.41	\$ 26.88	\$ 16.65	\$ 29.03	\$ 74.96	ICB
Bonita Springs	BNSPFLXA	2	\$15.41	\$ 26.88	\$ 16.65	\$ 29.03	\$ 74.96	ICB

Sanibel-Captiva Islands	SNISFLXA	2	\$15.41	\$ 26.88	\$ 16.65	\$ 29.03	\$ 74.96	ICB
West Kissimmee	KSSMFLXB	2	\$15.41	\$ 26.88	\$ 16.65	\$ 29.03	\$ 74.96	ICB
Kissimmee	KSSMFLXA	2	\$15.41	\$ 26.88	\$ 16.65	\$ 29.03	\$ 74.96	ICB

Windermere	WNDNFLXA	3	\$20.54	\$ 35.85	\$ 22.20	\$ 38.72	\$ 84.83	ICB
Highlands	OCALFLXC	3	\$20.54	\$ 35.85	\$ 22.20	\$ 38.72	\$ 84.83	ICB
Tallahassee - Parkins	TLHSFLXH	3	\$20.54	\$ 35.85	\$ 22.20	\$ 38.72	\$ 84.83	ICB
Eustis	ESTSFLXA	3	\$20.54	\$ 35.85	\$ 22.20	\$ 38.72	\$ 84.83	ICB
San Carlos Park	SCPKFLXA	3	\$20.54	\$ 35.85	\$ 22.20	\$ 38.72	\$ 84.83	ICB
North Cape Coral	CPCRFLXB	3	\$20.54	\$ 35.85	\$ 22.20	\$ 38.72	\$ 84.83	ICB
Tallahassee Blairstone	TLHSFLXD	3	\$20.54	\$ 35.85	\$ 22.20	\$ 38.72	\$ 84.83	ICB
Port Charlotte	PTCTFLXA	3	\$20.54	\$ 35.85	\$ 22.20	\$ 38.72	\$ 84.83	ICB
Golden Gate	GLGCFLXA	3	\$20.54	\$ 35.85	\$ 22.20	\$ 38.72	\$ 84.83	ICB
Tavares	TVRSFLXA	3	\$20.54	\$ 35.85	\$ 22.20	\$ 38.72	\$ 84.83	ICB
Apopka	APPKFLXA	3	\$20.54	\$ 35.85	\$ 22.20	\$ 38.72	\$ 84.83	ICB
Westville	WSTVFLXA	3	\$20.54	\$ 35.85	\$ 22.20	\$ 38.72	\$ 84.83	ICB
Ocala XA	OCALFLXA	3	\$20.54	\$ 35.85	\$ 22.20	\$ 38.72	\$ 84.83	ICB
Tallahassee - Mabry	TLHSFLXC	3	\$20.54	\$ 35.85	\$ 22.20	\$ 38.72	\$ 84.83	ICB
North Fort Myers XB	NFMYFLXB	3	\$20.54	\$ 35.85	\$ 22.20	\$ 38.72	\$ 84.83	ICB
Naples South East	NPLSFLXC	3	\$20.54	\$ 35.85	\$ 22.20	\$ 38.72	\$ 84.83	ICB
Winter Garden	WNGRFLXA	3	\$20.54	\$ 35.85	\$ 22.20	\$ 38.72	\$ 84.83	ICB
Leesburg	LSBGFLXA	3	\$20.54	\$ 35.85	\$ 22.20	\$ 38.72	\$ 84.83	ICB
Lady Lake (753)	LDLKFLXA	3	\$20.54	\$ 35.85	\$ 22.20	\$ 38.72	\$ 84.83	ICB
Deltona Lakes	ORCYFLXC	3	\$20.54	\$ 35.85	\$ 22.20	\$ 38.72	\$ 84.83	ICB
Sebring	SBNGFLXA	3	\$20.54	\$ 35.85	\$ 22.20	\$ 38.72	\$ 84.83	ICB

Shady Road	OCALFLXB	4	\$27.09	\$ 47.24	\$ 29.26	\$ 51.02	\$ 97.36	ICB
Silver Springs Shores	SVSSFLXA	4	\$27.09	\$ 47.24	\$ 29.26	\$ 51.02	\$ 97.36	ICB
Clermont	CLMTFLXA	4	\$27.09	\$ 47.24	\$ 29.26	\$ 51.02	\$ 97.36	ICB
Tallahassee Thomasville	TLHSFLXF	4	\$27.09	\$ 47.24	\$ 29.26	\$ 51.02	\$ 97.36	ICB
Lehigh Acres	LHACFLXA	4	\$27.09	\$ 47.24	\$ 29.26	\$ 51.02	\$ 97.36	ICB
East Fort Meyers	FTMYFLXB	4	\$27.09	\$ 47.24	\$ 29.26	\$ 51.02	\$ 97.36	ICB
Montverde	MTVRFLXA	4	\$27.09	\$ 47.24	\$ 29.26	\$ 51.02	\$ 97.36	ICB
Valparaiso/678	VLPRFLXA	4	\$27.09	\$ 47.24	\$ 29.26	\$ 51.02	\$ 97.36	ICB
Beverly Hills	BVHLFLXA	4	\$27.09	\$ 47.24	\$ 29.26	\$ 51.02	\$ 97.36	ICB
Cape Haze	CPHZFLXA	4	\$27.09	\$ 47.24	\$ 29.26	\$ 51.02	\$ 97.36	ICB
Dade City	DDCYFLXA	4	\$27.09	\$ 47.24	\$ 29.26	\$ 51.02	\$ 97.36	ICB
Punta Gorda	PNGRFLXA	4	\$27.09	\$ 47.24	\$ 29.26	\$ 51.02	\$ 97.36	ICB
Mount Dora	MTDRFLXA	4	\$27.09	\$ 47.24	\$ 29.26	\$ 51.02	\$ 97.36	ICB
Crestview	CRVWFLXA	4	\$27.09	\$ 47.24	\$ 29.26	\$ 51.02	\$ 97.36	ICB
Crystal River	CRRVFLXA	4	\$27.09	\$ 47.24	\$ 29.26	\$ 51.02	\$ 97.36	ICB
Lake Helen	LKHLFLXA	4	\$27.09	\$ 47.24	\$ 29.26	\$ 51.02	\$ 97.36	ICB
Clewiston	CLTNFLXA	4	\$27.09	\$ 47.24	\$ 29.26	\$ 51.02	\$ 97.36	ICB
Sea Grove Beach	SGBHFLXA	4	\$27.09	\$ 47.24	\$ 29.26	\$ 51.02	\$ 97.36	ICB
St. Cloud	STCDFLXA	4	\$27.09	\$ 47.24	\$ 29.26	\$ 51.02	\$ 97.36	ICB
Homosassa Spgs	HMSPFLLXA	4	\$27.09	\$ 47.24	\$ 29.26	\$ 51.02	\$ 97.36	ICB
Inverness	INVRFLXA	4	\$27.09	\$ 47.24	\$ 29.26	\$ 51.02	\$ 97.36	ICB
Oklawaha	OKLWFLXA	4	\$27.09	\$ 47.24	\$ 29.26	\$ 51.02	\$ 97.36	ICB

Madison	MDSNFLXA	4	\$27.09	\$ 47.24	\$ 29.26	\$ 51.02	\$ 97.36	ICB
Pine Island	PNISFLXA	4	\$27.09	\$ 47.24	\$ 29.26	\$ 51.02	\$ 97.36	ICB
Avon Park	AVPKFLXA	4	\$27.09	\$ 47.24	\$ 29.26	\$ 51.02	\$ 97.36	ICB
Silver Springs	SVSPFLXA	4	\$27.09	\$ 47.24	\$ 29.26	\$ 51.02	\$ 97.36	ICB
Belleview	BLVWFLXA	5	\$39.66	\$ 69.17	\$ 42.84	\$ 74.70	\$ 124.02	ICB
Chassohowitza	CHSWFLXA	5	\$39.66	\$ 69.17	\$ 42.84	\$ 74.70	\$ 124.02	ICB
Immokalee	IMKFLXA	5	\$39.66	\$ 69.17	\$ 42.84	\$ 74.70	\$ 124.02	ICB
Wildwood	WLWDFLXA	5	\$39.66	\$ 69.17	\$ 42.84	\$ 74.70	\$ 124.02	ICB
Moore Heaven	MRHNFLXA	5	\$39.66	\$ 69.17	\$ 42.84	\$ 74.70	\$ 124.02	ICB
Arcadia	ARCDLXA	5	\$39.66	\$ 69.17	\$ 42.84	\$ 74.70	\$ 124.02	ICB
Marianna	MRNNFLXA	5	\$39.66	\$ 69.17	\$ 42.84	\$ 74.70	\$ 124.02	ICB
Lake Placid	LKPCFLXA	5	\$39.66	\$ 69.17	\$ 42.84	\$ 74.70	\$ 124.02	ICB
Okeechobee	OKCBFLXA	5	\$39.66	\$ 69.17	\$ 42.84	\$ 74.70	\$ 124.02	ICB
Bushnell	BSHNFLXA	5	\$39.66	\$ 69.17	\$ 42.84	\$ 74.70	\$ 124.02	ICB
Santa Rosa Beach	SNRSFLXA	5	\$39.66	\$ 69.17	\$ 42.84	\$ 74.70	\$ 124.02	ICB
Alva	ALVAFLXA	5	\$39.66	\$ 69.17	\$ 42.84	\$ 74.70	\$ 124.02	ICB
Tallahassee XG	TLHSFLXG	5	\$39.66	\$ 69.17	\$ 42.84	\$ 74.70	\$ 124.02	ICB
Astor	ASTRFLXA	5	\$39.66	\$ 69.17	\$ 42.84	\$ 74.70	\$ 124.02	ICB
Spring Lake	SLHLFLXA	5	\$39.66	\$ 69.17	\$ 42.84	\$ 74.70	\$ 124.02	ICB
Wauchula	WCHLFLXA	5	\$39.66	\$ 69.17	\$ 42.84	\$ 74.70	\$ 124.02	ICB
Starke	STRKFLXA	5	\$39.66	\$ 69.17	\$ 42.84	\$ 74.70	\$ 124.02	ICB
San Antonio	SNANFLXA	5	\$39.66	\$ 69.17	\$ 42.84	\$ 74.70	\$ 124.02	ICB
Labelle	LBLFLXA	5	\$39.66	\$ 69.17	\$ 42.84	\$ 74.70	\$ 124.02	ICB
Groveland	GVLDFLXA	5	\$39.66	\$ 69.17	\$ 42.84	\$ 74.70	\$ 124.02	ICB
Bowling Green	BWLGFLXA	5	\$39.66	\$ 69.17	\$ 42.84	\$ 74.70	\$ 124.02	ICB
Fort Meade	FTMDFLXA	5	\$39.66	\$ 69.17	\$ 42.84	\$ 74.70	\$ 124.02	ICB
Howey-In-The-Hills	HOWYFLXA	5	\$39.66	\$ 69.17	\$ 42.84	\$ 74.70	\$ 124.02	ICB
Forest	OCNFFLXA	5	\$39.66	\$ 69.17	\$ 42.84	\$ 74.70	\$ 124.02	ICB
Trilacoochee	TLCHFLXA	5	\$39.66	\$ 69.17	\$ 42.84	\$ 74.70	\$ 124.02	ICB
Crawfordville	CFVLFLXA	5	\$39.66	\$ 69.17	\$ 42.84	\$ 74.70	\$ 124.02	ICB
Everglades	EVRGFLXA	5	\$39.66	\$ 69.17	\$ 42.84	\$ 74.70	\$ 124.02	ICB
Salt Springs	SSPRFLXA	6	\$74.05	\$ 129.13	\$ 79.98	\$ 139.46	\$ 194.40	ICB
DeFuniak Springs	DFSPFLXA	6	\$74.05	\$ 129.13	\$ 79.98	\$ 139.46	\$ 194.40	ICB
Umatilla	UMTLFLXA	6	\$74.05	\$ 129.13	\$ 79.98	\$ 139.46	\$ 194.40	ICB
Sneads	SNDSFLXA	6	\$74.05	\$ 129.13	\$ 79.98	\$ 139.46	\$ 194.40	ICB
Williston	WLSTFLXA	6	\$74.05	\$ 129.13	\$ 79.98	\$ 139.46	\$ 194.40	ICB
Grand Ridge	GDRGFLXA	6	\$74.05	\$ 129.13	\$ 79.98	\$ 139.46	\$ 194.40	ICB
Zolfo Springs	ZLSPFLXA	6	\$74.05	\$ 129.13	\$ 79.98	\$ 139.46	\$ 194.40	ICB
Monticello	MNTIFLXA	6	\$74.05	\$ 129.13	\$ 79.98	\$ 139.46	\$ 194.40	ICB
St. Marks	STMKFLXA	6	\$74.05	\$ 129.13	\$ 79.98	\$ 139.46	\$ 194.40	ICB
Freeport	FRPTFLXA	6	\$74.05	\$ 129.13	\$ 79.98	\$ 139.46	\$ 194.40	ICB
Bonifay	BNFYFLXA	6	\$74.05	\$ 129.13	\$ 79.98	\$ 139.46	\$ 194.40	ICB
Cottondale	CTDLFLXA	6	\$74.05	\$ 129.13	\$ 79.98	\$ 139.46	\$ 194.40	ICB
Lawtey	LWTFYFLXA	6	\$74.05	\$ 129.13	\$ 79.98	\$ 139.46	\$ 194.40	ICB
Panacea	PANCFLXA	6	\$74.05	\$ 129.13	\$ 79.98	\$ 139.46	\$ 194.40	ICB
Reynolds Hill	RYHLFLXA	6	\$74.05	\$ 129.13	\$ 79.98	\$ 139.46	\$ 194.40	ICB

Sopchoppy	SPCPFLXA	6	\$74.05	\$ 129.13	\$	79.98	\$ 139.46	\$	194.40	ICB
Malone	MALNFLXA	6	\$74.05	\$ 129.13	\$	79.98	\$ 139.46	\$	194.40	ICB
Baker	BAKRFLXA	6	\$74.05	\$ 129.13	\$	79.98	\$ 139.46	\$	194.40	ICB
Alford	ALFRFLXA	6	\$74.05	\$ 129.13	\$	79.98	\$ 139.46	\$	194.40	ICB
Kingsley Lake	KGLKFLXA	6	\$74.05	\$ 129.13	\$	79.98	\$ 139.46	\$	194.40	ICB
Greenville	GNVFLXA	6	\$74.05	\$ 129.13	\$	79.98	\$ 139.46	\$	194.40	ICB
Ponce de Leon	PNLNFLXA	6	\$74.05	\$ 129.13	\$	79.98	\$ 139.46	\$	194.40	ICB
Kenansville	KNVFLXA	6	\$74.05	\$ 129.13	\$	79.98	\$ 139.46	\$	194.40	ICB
Lee	LEE FLXA	6	\$74.05	\$ 129.13	\$	79.98	\$ 139.46	\$	194.40	ICB
Glendale	GLDLFLXA	6	\$74.05	\$ 129.13	\$	79.98	\$ 139.46	\$	194.40	ICB
Cherry Lake	CHLKFLXA	6	\$74.05	\$ 129.13	\$	79.98	\$ 139.46	\$	194.40	ICB
Greenwood	GNWDFLXA	6	\$74.05	\$ 129.13	\$	79.98	\$ 139.46	\$	194.40	ICB

### LOCAL SWITCHING

EXCHANGE	BAND	RATE
ALTAMONTE SPRINGS, FL	1	\$7.00
BONITA SPRINGS, FL	1	\$7.00
CYPRESS LAKE, FL	1	\$7.00
FT MYERS BEACH, FL	1	\$7.00
FT. MYERS, FL	1	\$7.00
FT. WALTON BEACH, FL	1	\$7.00
GOLDENROD, FL	1	\$7.00
LAKE BRANTLEY, FL	1	\$7.00
TALLAHASSEE, FL	1	\$7.00
WINTER PARK, FL	1	\$7.00
APOPKA, FL	2	\$7.00
CASSELBERRY, FL	2	\$7.00
CHERRY LAKE, FL	2	\$7.00
EUSTIS, FL	2	\$7.00
FREEPORT, FL	2	\$7.00
KISSIMMEE, FL	2	\$7.00
LEESBURG, FL	2	\$7.00
NAPLES MOORINGS, FL	2	\$7.00
NAPLES, FL	2	\$7.00
OCALA, FL	2	\$7.00
ORANGE CITY, FL	2	\$7.00
PORT CHARLOTTE, FL	2	\$7.00
TAVARES, FL	2	\$7.00
VALPRAISO, FL	2	\$7.00
WILDWOOD, FL	2	\$7.00
ALFORD, FL	3	\$7.00
ARCADIA, FL	3	\$7.00

ASTOR, FL	3	\$7.00
AVON PARK, FL	3	\$7.00
BAKER, FL	3	\$7.00
BELLEVIEW, FL	3	\$7.00
BEVERLY HILLS, FL	3	\$7.00
BONIFAY, FL	3	\$7.00
BOWLING GREEN, FL	3	\$7.00
COTTONDALE, FL	3	\$7.00
CRESTVIEW, FL	3	\$7.00
CRYSTAL RIVER, FL	3	\$7.00
DADE CITY, FL	3	\$7.00
DESTIN, FL	3	\$7.00
EVERGLADES, FL	3	\$7.00
FOREST, FL	3	\$7.00
GLENDALE, FL	3	\$7.00
GREENVILLE, FL	3	\$7.00
GREENWOOD, FL	3	\$7.00
HOMOSASSA SPRINGS, FL	3	\$7.00
HOWEY-IN-THE-HILLS, FL	3	\$7.00
IMMOKALEE, FL	3	\$7.00
INVERNESS, FL	3	\$7.00
KENANSVILLE, FL	3	\$7.00
KINGSLEY LAKE, FL	3	\$7.00
LABELLE, FL	3	\$7.00
LADY LAKE, FL	3	\$7.00
LAWTEY, FL	3	\$7.00
LEE, FL	3	\$7.00
LEHIGH ACRES, FL	3	\$7.00
MADISON, FL	3	\$7.00
MAITLAND, FL	3	\$7.00
MALONE, FL	3	\$7.00
MARCO ISLAND, FL	3	\$7.00
MONTICELLO, FL	3	\$7.00
MONTVERDE, FL	3	\$7.00
MT. DORA, FL	3	\$7.00
NORTH NAPLES, FL	3	\$7.00
OKEECHOBEE, FL	3	\$7.00
OKLAWAHA, FL	3	\$7.00
PANACEA, FL	3	\$7.00
PONCE DE LEON, FL	3	\$7.00
REYNOLDS HILL, FL	3	\$7.00
SALT SPRINGS, FL	3	\$7.00
SANTA ROSA, FL	3	\$7.00
SEA GROVE BEACH, FL	3	\$7.00
SHADY ROAD, FL	3	\$7.00
SILVER SPRINGS SHORES, FL	3	\$7.00
SNEADS, FL	3	\$7.00
SOPCHOPPY, FL	3	\$7.00
ST. CLOUD, FL	3	\$7.00

ST. MARKS, FL	3	\$7.00
STARKE, FL	3	\$7.00
UMATILLA, FL	3	\$7.00
WEST KISSIMMEE, FL	3	\$7.00
WESTVILLE, FL	3	\$7.00
WILLISTON, FL	3	\$7.00
WINTER GARDEN, FL	3	\$7.00
BOCA GRANDE, FL	4	\$7.00
CAPE CORAL, FL	4	\$7.00
CLERMONT, FL	4	\$7.00
CLEWISTON, FL	4	\$7.00
CRAWFORDVILLE, FL	4	\$7.00
DEFUNIAK SPRINGS, FL	4	\$7.00
FORT MEADE, FL	4	\$7.00
MOORE HAVEN, FL	4	\$7.00
NORTH CAPE CORAL, FL	4	\$7.00
NORTH FT. MYERS, FL	4	\$7.00
PINE ISLAND, FL	4	\$7.00
REEDY CREEK, FL	4	\$7.00
WAUCHULA, FL	4	\$7.00
WINDERMERE, FL	4	\$7.00
ZOLFO SPRINGS, FL	4	\$7.00
BUSHNELL, FL	5	\$7.00
CAPE HAZE, FL	5	\$7.00
GROVELAND, FL	5	\$7.00
LAKE PLACID, FL	5	\$7.00
MARIANNA, FL	5	\$7.00
PUNTA GORDA, FL	5	\$7.00
SAN ANTONIO, FL	5	\$7.00
SANIBEL ISLAND, FL	5	\$7.00
SEBRING, FL	5	\$7.00
SHALIMAR, FL	5	\$7.00
SPRING LAKE, FL	5	\$7.00
TRILLACOOCHEE, FL	5	\$7.00

**END OFFICE**

<u>EXCHANGE</u>	<u>RATE</u>
ALFORD, FL	\$0.003671
APOPKA, FL	\$0.003671
ARCADIA, FL	\$0.003671
ASTOR, FL	\$0.003671
AVON PARK, FL	\$0.003671

BAKER, FL	\$0.003671
BELLEVIEW, FL	\$0.003671
BEVERLY HILLS, FL	\$0.003671
BOCA GRANDE, FL	\$0.003671
BONIFAY, FL	\$0.003671
BONITA SPRINGS, FL	\$0.003671
BOWLING GREEN, FL	\$0.003671
BUSHNELL, FL	\$0.003671
CAPE CORAL, FL	\$0.003671
CAPE HAZE, FL	\$0.003671
CASSELBERRY, FL	\$0.003671
CHERRY LAKE, FL	\$0.003671
CLERMONT, FL	\$0.003671
CLEWISTON, FL	\$0.003671
COTTONDALE, FL	\$0.003671
CRAWFORDVILLE, FL	\$0.003671
CRESTVIEW, FL	\$0.003671
CRYSTAL RIVER, FL	\$0.003671
CYPRESS LAKE, FL	\$0.003671
DADE CITY, FL	\$0.003671
DEFUNIAK SPRINGS, FL	\$0.003671
DESTIN, FL	\$0.003671
EUSTIS, FL	\$0.003671
EVERGLADES, FL	\$0.003671
FOREST, FL	\$0.003671
FORT MEADE, FL	\$0.003671
FREEPORT, FL	\$0.003671
FT MYERS BEACH, FL	\$0.003671
FT. MYERS, FL	\$0.003671
FT. WALTON BEACH, FL	\$0.003671
GLENDALE, FL	\$0.003671
GOLDENROD, FL	\$0.003671
GREENVILLE, FL	\$0.003671
GREENWOOD, FL	\$0.003671
GROVELAND, FL	\$0.003671
HOMOSASSA SPRINGS, FL	\$0.003671
HOWEY-IN-THE-HILLS, FL	\$0.003671
IMMOKALEE, FL	\$0.003671
INVERNESS, FL	\$0.003671
KENANSVILLE, FL	\$0.003671
KINGSLEY LAKE, FL	\$0.003671
KISSIMEE, FL	\$0.003671
LABELLE, FL	\$0.003671
LADY LAKE, FL	\$0.003671
LAKE BRANTLEY, FL	\$0.003671
LAKE PLACID, FL	\$0.003671
LAWTEY, FL	\$0.003671
LEE, FL	\$0.003671
LEESBURG, FL	\$0.003671



LEHIGH ACRES, FL	\$0.003671
MADISON, FL	\$0.003671
MAITLAND, FL	\$0.003671
MALONE, FL	\$0.003671
MARCO ISLAND, FL	\$0.003671
MARIANNA, FL	\$0.003671
MONTICELLO , FL	\$0.003671
MONTVERDE, FL	\$0.003671
MOORE HAVEN, FL	\$0.003671
MT. DORA, FL	\$0.003671
NAPLES MOORINGS, FL	\$0.003671
NAPLES, FL	\$0.003671
NORTH CAPE CORAL, FL	\$0.003671
NORTH FT. MYERS, FL	\$0.003671
NORTH NAPLES, FL	\$0.003671
OCALA, FL	\$0.003671
OKEECHOBEE, FL	\$0.003671
OKLAWAHA, FL	\$0.003671
ORANGE CITY, FL	\$0.003671
PANACEA, FL	\$0.003671
PINE ISLAND, FL	\$0.003671
PONCE DE LEON, FL	\$0.003671
PORT CHARLOTTE, FL	\$0.003671
PUNTA GORDA, FL	\$0.003671
REEDY CREEK, FL	\$0.003671
REYNOLDS HILL, FL	\$0.003671
SALT SPRINGS, FL	\$0.003671
SAN ANTONIO, FL	\$0.003671
SANIBEL ISLAND, FL	\$0.003671
SANTA ROSA, FL	\$0.003671
SEA GROVE BEACH, FL	\$0.003671
SEBRING, FL	\$0.003671
SHADY ROAD, FL	\$0.003671
SHALIMAR, FL	\$0.003671
SILVER SPRINGS SHORES, FL	\$0.003671
SNEADS, FL	\$0.003671
SOPCHOPPY, FL	\$0.003671
SPRING LAKE, FL	\$0.003671
ST. CLOUD, FL	\$0.003671
ST. MARKS, FL	\$0.003671
STARKE, FL	\$0.003671
TALLAHASSEE, FL	\$0.003671
TAVARES, FL	\$0.003671
TRILLACOOCHEE, FL	\$0.003671
UMATILLA, FL	\$0.003671
VALPRAISO, FL	\$0.003671
WAUCHULA, FL	\$0.003671
WEST KISSIMMEE, FL	\$0.003671
WESTVILLE, FL	\$0.003671

WILDWOOD, FL	\$0.003671
WILLISTON, FL	\$0.003671
WINDERMERE, FL	\$0.003671
WINTER GARDEN, FL	\$0.003671
WINTER PARK, FL	\$0.003671
ZOLFO SPRINGS, FL	\$0.003671

## TRANSPORT BANDS

Florida Bands                      9/8/98 filing

Bands	DS1	DS3
1	\$ 71.95	\$ 1,178.36
2	\$ 86.39	\$ 1,771.38
3	\$ 114.14	\$ 2,356.73
4	\$ 124.39	\$ 2,654.34
5	\$ 131.95	\$ 2,771.35
6	\$ 136.41	\$ 2,949.75
7	\$ 138.82	\$ 3,247.36
8	\$ 149.76	\$ 3,535.09
9	\$ 156.33	\$ 3,832.70
10	\$ 158.34	\$ 3,949.71
11	\$ 174.14	\$ 4,425.72
12	\$ 174.82	\$ 5,011.07
13	\$ 184.39	\$ 5,018.74
14	\$ 188.84	\$ 5,308.68
15	\$ 191.95	\$ 5,512.99
16	\$ 196.34	\$ 5,604.09
17	\$ 202.19	\$ 5,901.70
18	\$ 206.77	\$ 6,197.11
19	\$ 210.77	\$ 6,487.04
20	\$ 227.25	\$ 6,494.72
21	\$ 229.95	\$ 6,512.95
22	\$ 238.53	\$ 6,691.36
23	\$ 247.76	\$ 7,080.05
24	\$ 248.78	\$ 7,284.33
25	\$ 256.34	\$ 7,375.47
26	\$ 260.80	\$ 7,665.40
27	\$ 263.21	\$ 7,673.08
28	\$ 265.56	\$ 8,258.42
29	\$ 271.23	\$ 8,760.35
30	\$ 274.14	\$ 9,760.31
31	\$ 278.72	\$ 9,938.72
32	\$ 307.76	\$ 11,117.08
33	\$ 318.00	\$ 11,821.63
34	\$ 326.58	\$ 12,593.05

35	\$	331.16	\$	12,888.46
36	\$	335.16	\$	13,771.42
37	\$	345.60	\$	15,066.99
38	\$	363.56		
39	\$	389.95		
40	\$	395.62		
41	\$	408.97		
42	\$	454.53		
43	\$	504.27		
44	\$	514.53		
45	\$	533.35		
46	\$	570.34		
47	\$	628.66		
48		\$458.07		
49		\$474.31		
50		\$477.27		
51		\$519.78		
52		\$524.05		
53		\$526.54		
54		\$578.30		
55		\$665.28		
56		\$696.81		
57		\$729.33		
58		\$732.29		
59		\$835.55		
60		\$1,364.32		
61		\$1,773.11		
62		\$2,075.02		
63		\$2,181.90		
64		\$2,430.37		

**TRANSPORT**

Sprint Florida

Updated 6/24/99

Updated  
6/24/99  
09/98 E19  
Price List

09/98 E19 Price List

Originating	Originating	Terminating	Dedicated DS1	Dedicated DS3	
ALFRFLXA	ALFRFLXA	CTDLFLXA	\$ 86.39	\$ 1,178.36	0.000711
ALFRFLXA	ALFRFLXA	MRNNFLXA	\$ 149.76	\$ 2,356.73	0.000711
ALSPFLXA	ALSPFLXA	APPKFLXA	\$ 71.95	\$ 1,178.36	0.000711
ALSPFLXA	ALSPFLXA	CSLBFLXA	\$ 86.39	\$ 1,178.36	0.000711

ALSPFLXA	ALSPFLXA	CLBRFLAD	\$	156.33	\$	3,535.09	0.000711
ALSPFLXA	ALSPFLXA	EORNFLXA	\$	114.14	\$	2,356.73	0.000711
ALSPFLXA	ALSPFLXA	GENVFLXA	\$	114.14	\$	2,356.73	0.000711
ALSPFLXA	ALSPFLXA	GLRDFLXA	\$	86.39	\$	1,178.36	0.000711
ALSPFLXA	ALSPFLXA	LKBRFLXA	\$	71.95	\$	1,178.36	0.000711
ALSPFLXA	ALSPFLXA	LKBNFLXA	\$	156.33	\$	3,535.09	0.000711
ALSPFLXA	ALSPFLXA	MTLDFLXA	\$	71.95	\$	1,178.36	0.000711
ALSPFLXA	ALSPFLXA	MTVRFLXA	\$	238.53	\$	5,604.09	0.000711
ALSPFLXA	ALSPFLXA	OFLDFLXA	\$	114.14	\$	2,356.73	0.000711
ALSPFLXA	ALSPFLXA	OVIDFLCA	\$	114.14	\$	2,356.73	0.000711
ALSPFLXA	ALSPFLXA	KSSMFLXC	\$	174.14	\$	3,535.09	0.000711
ALSPFLXA	ALSPFLXA	SNFRFLMA	\$	114.14	\$	2,356.73	0.000711
ALSPFLXA	ALSPFLXA	WNDRFLXA	\$	174.14	\$	3,535.09	0.000711
ALSPFLXA	ALSPFLXA	WNGRFLXA	\$	114.14	\$	2,356.73	0.000711
ALSPFLXA	ALSPFLXA	WNPKFLXA	\$	86.39	\$	1,178.36	0.000711
ALVAFLXA	ALVAFLXA	BNSPFLXA	\$	86.39	\$	1,178.36	0.000711
ALVAFLXA	ALVAFLXA	CPCRFLXA	\$	136.41	\$	2,771.35	0.000711
ALVAFLXA	ALVAFLXA	FTMYFLXB	\$	86.39	\$	1,178.36	0.000711
ALVAFLXA	ALVAFLXA	RGAPFLXA	\$	158.34	\$	2,949.75	0.000711
ALVAFLXA	ALVAFLXA	FTMYFLXA	\$	86.39	\$	1,178.36	0.000711
ALVAFLXA	ALVAFLXA	FTMBFLXA	\$	71.95	\$	1,178.36	0.000711
ALVAFLXA	ALVAFLXA	LHACFLXA	\$	86.39	\$	1,178.36	0.000711
ALVAFLXA	ALVAFLXA	CPCRFLXB	\$	136.41	\$	2,771.35	0.000711
ALVAFLXA	ALVAFLXA	NFMYFLXA	\$	136.41	\$	2,771.35	0.000711
ALVAFLXA	ALVAFLXA	PNISFLXA	\$	71.95	\$	1,178.36	0.000711
ALVAFLXA	ALVAFLXA	SNISFLXA	\$	71.95	\$	1,178.36	0.000711
ALVAFLXA	ALVAFLXA	FTMYFLXC	\$	86.39	\$	1,178.36	0.000711
APPKFLXA	APPKFLXA	CSLBFLXA	\$	131.95	\$	2,356.73	0.000711
APPKFLXA	APPKFLXA	CLBRFLAD	\$	114.14	\$	2,356.73	0.000711
APPKFLXA	APPKFLXA	EOFINFLXA	\$	114.14	\$	2,356.73	0.000711
APPKFLXA	APPKFLXA	GLRDFLXA	\$	131.95	\$	2,356.73	0.000711
APPKFLXA	APPKFLXA	LKBRFLXA	\$	71.95	\$	1,178.36	0.000711
APPKFLXA	APPKFLXA	LKBNFLXA	\$	114.14	\$	2,356.73	0.000711
APPKFLXA	APPKFLXA	MTLDFLXA	\$	71.95	\$	1,178.36	0.000711
APPKFLXA	APPKFLXA	MTVRFLXA	\$	210.77	\$	4,425.72	0.000711
APPKFLXA	APPKFLXA	ORLDFLXA	\$	114.14	\$	2,356.73	0.000711
APPKFLXA	APPKFLXA	KSSMFLXC	\$	131.95	\$	2,356.73	0.000711
APPKFLXA	APPKFLXA	WNDRFLXA	\$	131.95	\$	2,356.73	0.000711
APPKFLXA	APPKFLXA	WNGRFLXA	\$	71.95	\$	1,178.36	0.000711
APPKFLXA	APPKFLXA	WNPKFLXA	\$	71.95	\$	1,178.36	0.000711
ASTRFLXA	ASTRFLXA	CLMTFLXA	\$	202.19	\$	4,425.72	0.000711
ASTRFLXA	ASTRFLXA	ESTSFLXA	\$	202.19	\$	4,425.72	0.000711
ASTRFLXA	ASTRFLXA	GVLDFLXA	\$	318.00	\$	7,080.06	0.000711
ASTRFLXA	ASTRFLXA	HOWYFLXA	\$	326.58	\$	7,673.08	0.000711

ASTRFLXA	ASTRFLXA	LDLKFLXA	\$	265.56	\$	6,197.11	0.000711
ASTRFLXA	ASTRFLXA	LSBGFLXA	\$	202.19	\$	4,425.72	0.000711
ASTRFLXA	ASTRFLXA	MTRVFLXA	\$	326.58	\$	7,673.08	0.000711
ASTRFLXA	ASTRFLXA	MTRDFLXA	\$	202.19	\$	4,425.72	0.000711
ASTRFLXA	ASTRFLXA	TVRSFLXA	\$	202.19	\$	4,425.72	0.000711
ASTRFLXA	ASTRFLXA	UMTLFLXA	\$	138.82	\$	3,247.36	0.000711
BAKRFLXA	BAKRFLXA	CFVWFLXA	\$	124.39	\$	3,247.36	0.000711
BLVWFLXA	BLVWFLXA	CITRFLXA	\$	263.21	\$	5,308.68	0.000711
BLVWFLXA	BLVWFLXA	DNLNFLXA	\$	184.39	\$	3,832.70	0.000711
BLVWFLXA	BLVWFLXA	OCNFFLXA	\$	247.75	\$	5,604.09	0.000711
BLVWFLXA	BLVWFLXA	OCALFLXC	\$	131.95	\$	2,356.73	0.000711
BLVWFLXA	BLVWFLXA	LDLKFLXB	\$	86.39	\$	1,771.38	0.000711
BLVWFLXA	BLVWFLXA	MCINFLXA	\$	263.21	\$	5,308.68	0.000711
BLVWFLXA	BLVWFLXA	OCALFLXA	\$	138.82	\$	2,654.34	0.000711
BLVWFLXA	BLVWFLXA	OKLWFLXA	\$	71.95	\$	1,178.36	0.000711
BLVWFLXA	BLVWFLXA	ORSPFLXA	\$	263.21	\$	5,308.68	0.000711
BLVWFLXA	BLVWFLXA	SSPRFLXA	\$	454.53	\$	11,117.08	0.000711
BLVWFLXA	BLVWFLXA	SVSSFLXA	\$	71.95	\$	1,178.36	0.000711
BVHLFLXA	BVHLFLXA	CHSWFLXA	\$	260.80	\$	5,018.74	0.000711
BVHLFLXA	BVHLFLXA	CRRVFLXA	\$	188.84	\$	3,247.36	0.000711
BVHLFLXA	BVHLFLXA	HMSPLXA	\$	188.84	\$	3,247.36	0.000711
BVHLFLXA	BVHLFLXA	INVRFLXA	\$	188.84	\$	3,247.36	0.000711
BNFYFLXA	BNFYFLXA	RYHLFLXA	\$	71.95	\$	1,771.38	0.000711
BNFYFLXA	BNFYFLXA	WSTVFLXA	\$	124.39	\$	3,247.36	0.000711
BNSPFLXA	BNSPFLXA	CYLKFLXA	\$	86.39	\$	1,178.36	0.000711
BNSPFLXA	BNSPFLXA	FTMYFLXB	\$	86.39	\$	1,178.36	0.000711
BNSPFLXA	BNSPFLXA	FTMYFLXA	\$	86.39	\$	1,178.36	0.000711
BNSPFLXA	BNSPFLXA	FTMBFLXA	\$	131.95	\$	2,356.73	0.000711
BNSPFLXA	BNSPFLXA	GLGCFLXA	\$	86.39	\$	1,178.36	0.000711
BNSPFLXA	BNSPFLXA	NPLSFLXA	\$	86.39	\$	1,178.36	0.000711
BNSPFLXA	BNSPFLXA	NPLSFLXD	\$	86.39	\$	1,178.36	0.000711
BNSPFLXA	BNSPFLXA	NPLSFLXC	\$	86.39	\$	1,178.36	0.000711
BNSPFLXA	BNSPFLXA	NNFLFLXA	\$	86.39	\$	1,178.36	0.000711
BWLGFLXA	BWLGFLXA	WCHLFLXA	\$	86.39	\$	1,178.36	0.000711
BWLGFLXA	BWLGFLXA	ZLSPFLXA	\$	124.39	\$	2,654.34	0.000711
KSSMFLXD	KSSMFLXD	KSSMFLXA	\$	71.95	\$	1,771.38	0.000711
BSHNFLXA	BSHNFLXA	WLWDFLXA	\$	202.19	\$	4,425.72	0.000711
CPCRFLXA	CPCRFLXA	CYLKFLXA	\$	136.41	\$	2,771.35	0.000711
CPCRFLXA	CPCRFLXA	FTMYFLXB	\$	136.41	\$	2,771.35	0.000711
CPCRFLXA	CPCRFLXA	FTMYFLXA	\$	136.41	\$	2,771.35	0.000711
CPCRFLXA	CPCRFLXA	FTMBFLXA	\$	174.82	\$	3,949.71	0.000711
CPCRFLXA	CPCRFLXA	CPCRFLXB	\$	136.41	\$	2,771.35	0.000711
CPCRFLXA	CPCRFLXA	NFMYFLXA	\$	136.41	\$	2,771.35	0.000711
CPCRFLXA	CPCRFLXA	PNISFLXA	\$	174.82	\$	3,949.71	0.000711

CPCRFLXA	CPCRFLXA	SMSFLXA	\$	174.82	\$	3,949.71	0.000711
CSLBFLXA	CSLBFLXA	CLBRFLAD	\$	174.14	\$	3,535.09	0.000711
CSLBFLXA	CSLBFLXA	EORNFLXA	\$	131.95	\$	2,356.73	0.000711
CSLBFLXA	CSLBFLXA	GENVFLXA	\$	131.95	\$	2,356.73	0.000711
CSLBFLXA	CSLBFLXA	GLRDFLXA	\$	86.39	\$	1,178.36	0.000711
CSLBFLXA	CSLBFLXA	LKBRFLXA	\$	131.95	\$	2,356.73	0.000711
CSLBFLXA	CSLBFLXA	LKBNFLXA	\$	174.14	\$	3,535.09	0.000711
CSLBFLXA	CSLBFLXA	MTLDFLXA	\$	131.95	\$	2,356.73	0.000711
CSLBFLXA	CSLBFLXA	MTVRFLXA	\$	256.34	\$	5,604.09	0.000711
CSLBFLXA	CSLBFLXA	ORLDFLXA	\$	131.95	\$	2,356.73	0.000711
CSLBFLXA	CSLBFLXA	OVIDFLCA	\$	131.95	\$	2,356.73	0.000711
CSLBFLXA	CSLBFLXA	KSSMFLXC	\$	191.95	\$	3,535.09	0.000711
CSLBFLXA	CSLBFLXA	SNFRFLMA	\$	131.95	\$	2,356.73	0.000711
CSLBFLXA	CSLBFLXA	WNRDFLXA	\$	191.95	\$	3,535.09	0.000711
CSLBFLXA	CSLBFLXA	WNGRFLXA	\$	131.95	\$	2,356.73	0.000711
CSLBFLXA	CSLBFLXA	WNPKFLXA	\$	86.39	\$	1,178.36	0.000711
CHSWFLXA	CHSWFLXA	CRHVFLXA	\$	260.80	\$	5,018.74	0.000711
CHSWFLXA	CHSWFLXA	HMSFPLXA	\$	71.95	\$	1,771.38	0.000711
CHSWFLXA	CHSWFLXA	INVRFLXA	\$	260.80	\$	5,018.74	0.000711
CHLKFLXA	CHLKFLXA	GNVFLXA	\$	331.16	\$	8,760.35	0.000711
CHLKFLXA	CHLKFLXA	LEE_FLXA	\$	278.72	\$	7,284.38	0.000711
CHLKFLXA	CHLKFLXA	MDSNFLXA	\$	206.77	\$	5,512.99	0.000711
CLMTFLXA	CLMTFLXA	CLBRFLAD	\$	131.95	\$	2,356.73	0.000711
CLMTFLXA	CLMTFLXA	ESTSFLXA	\$	86.39	\$	1,178.36	0.000711
CLMTFLXA	CLMTFLXA	GVLDFLXA	\$	138.82	\$	2,654.34	0.000711
CLMTFLXA	CLMTFLXA	HOWYFLXA	\$	210.77	\$	4,425.72	0.000711
CLMTFLXA	CLMTFLXA	LDLKFLXA	\$	202.19	\$	4,425.72	0.000711
CLMTFLXA	CLMTFLXA	LSBGFLXA	\$	86.39	\$	1,178.36	0.000711
CLMTFLXA	CLMTFLXA	LKBNFLXA	\$	131.95	\$	2,356.73	0.000711
CLMTFLXA	CLMTFLXA	MTVRFLXA	\$	210.77	\$	4,425.72	0.000711
CLMTFLXA	CLMTFLXA	MTDRFLXA	\$	86.39	\$	1,178.36	0.000711
CLMTFLXA	CLMTFLXA	ORLDFLXA	\$	174.14	\$	3,535.09	0.000711
CLMTFLXA	CLMTFLXA	KSSMFLXC	\$	86.39	\$	1,178.36	0.000711
CLMTFLXA	CLMTFLXA	TVRSFLXA	\$	86.39	\$	1,178.36	0.000711
CLMTFLXA	CLMTFLXA	UMTLFLXA	\$	202.19	\$	4,425.72	0.000711
CLMTFLXA	CLMTFLXA	WNRDFLXA	\$	191.95	\$	3,535.09	0.000711
CLMTFLXA	CLMTFLXA	WNGRFLXA	\$	86.39	\$	1,178.36	0.000711
CTDLFLXA	CTDLFLXA	MRNNFLXA	\$	86.39	\$	1,178.36	0.000711
CFVLFLXA	CFVLFLXA	ARPNFLXA *	\$	504.27	\$	11,821.63	0.000711
CFVLFLXA	CFVLFLXA	CRBLFLXA	\$	504.27	\$	11,821.63	0.000711
CFVLFLXA	CFVLFLXA	PNACFLXA	\$	124.39	\$	3,247.36	0.000711
CFVLFLXA	CFVLFLXA	SPCPFLXA	\$	271.23	\$	6,512.95	0.000711
CFVLFLXA	CFVLFLXA	STMKFLXA	\$	124.39	\$	3,247.36	0.000711
CFVLFLXA	CFVLFLXA	TLHSFLXD	\$	271.23	\$	6,512.95	0.000711

CRVWFLXA	CRVWFLXA	LRHLFLXA *	\$	71.95	\$	1,178.36	0.000711
CRRVFLXA	CRRVFLXA	HMSPLXA	\$	188.84	\$	3,247.36	0.000711
CRRVFLXA	CRRVFLXA	INVRFLXA	\$	188.84	\$	3,247.36	0.000711
CRRVFLXA	CRRVFLXA	YNTWFLMA	\$	227.25	\$	4,425.72	0.000711
CYLKFLXA	CYLKFLXA	FTMYFLXB	\$	86.39	\$	1,178.36	0.000711
CYLKFLXA	CYLKFLXA	RGAPFLXA	\$	71.95	\$	1,771.38	0.000711
CYLKFLXA	CYLKFLXA	FTMYFLXA	\$	86.39	\$	1,178.36	0.000711
CYLKFLXA	CYLKFLXA	FTMBFLXA	\$	71.95	\$	1,178.36	0.000711
CYLKFLXA	CYLKFLXA	LHACFLXA	\$	86.39	\$	1,178.36	0.000711
CYLKFLXA	CYLKFLXA	CPCRFLXB	\$	136.41	\$	2,771.35	0.000711
CYLKFLXA	CYLKFLXA	NFMYFLXA	\$	71.95	\$	1,178.36	0.000711
CYLKFLXA	CYLKFLXA	PNISFLXA	\$	71.95	\$	1,178.36	0.000711
CYLKFLXA	CYLKFLXA	SNISFLXA	\$	71.95	\$	1,178.36	0.000711
CYLKFLXA	CYLKFLXA	FTMYFLXC	\$	86.39	\$	1,178.36	0.000711
DDCYFLXA	DDCYFLXA	SNANFLXA	\$	86.39	\$	1,178.36	0.000711
DDCYFLXA	DDCYFLXA	TLCHFLXA	\$	86.39	\$	1,178.36	0.000711
DDCYFLXA	DDCYFLXA	ZPHYFLXA	\$	71.95	\$	1,178.36	0.000711
DFSPFLXA	DFSPFLXA	FRPTFLXA	\$	86.39	\$	1,178.36	0.000711
DFSPFLXA	DFSPFLXA	GLDLFLXA	\$	124.39	\$	3,247.36	0.000711
DFSPFLXA	DFSPFLXA	PXTNFLXA *	\$	131.95	\$	2,356.73	0.000711
DFSPFLXA	DFSPFLXA	PNLNFLXA	\$	124.39	\$	3,247.36	0.000711
ORCYFLXC	ORCYFLXC	LKHNFLXA	\$	71.95	\$	1,771.38	0.000711
ORCYFLXC	ORCYFLXC	ORCYFLXA	\$	71.95	\$	1,771.38	0.000711
DESTFLXA	DESTFLXA	FTWBFLXA	\$	86.39	\$	1,178.36	0.000711
DESTFLXA	DESTFLXA	VLPRFLXA	\$	86.39	\$	1,178.36	0.000711
DESTFLXA	DESTFLXA	SNRSFLXA	\$	86.39	\$	1,178.36	0.000711
DESTFLXA	DESTFLXA	SHLMFLXA	\$	86.39	\$	1,178.36	0.000711
DESTFLXA	DESTFLXA	VLPRFLXA	\$	86.39	\$	1,178.36	0.000711
FTMYFLXB	FTMYFLXB	RGAPFLXA	\$	158.34	\$	2,949.75	0.000711
FTMYFLXB	FTMYFLXB	FTMYFLXA	\$	86.39	\$	1,178.36	0.000711
FTMYFLXB	FTMYFLXB	FTMBFLXA	\$	71.95	\$	1,178.36	0.000711
FTMYFLXB	FTMYFLXB	LHACFLXA	\$	86.39	\$	1,178.36	0.000711
FTMYFLXB	FTMYFLXB	CPCRFLXB	\$	136.41	\$	2,771.35	0.000711
FTMYFLXB	FTMYFLXB	NFMYFLXA	\$	136.41	\$	2,771.35	0.000711
FTMYFLXB	FTMYFLXB	PNISFLXA	\$	71.95	\$	1,178.36	0.000711
FTMYFLXB	FTMYFLXB	SNISFLXA	\$	71.95	\$	1,178.36	0.000711
FTMYFLXB	FTMYFLXB	FTMYFLXC	\$	86.39	\$	1,178.36	0.000711
ESTSFLXA	ESTSFLXA	GVLDFLXA	\$	202.19	\$	3,832.70	0.000711
ESTSFLXA	ESTSFLXA	HOWYFLXA	\$	210.77	\$	4,425.72	0.000711
ESTSFLXA	ESTSFLXA	LDLKFLXA	\$	149.76	\$	2,949.75	0.000711
ESTSFLXA	ESTSFLXA	LSBGFLXA	\$	86.39	\$	1,178.36	0.000711
ESTSFLXA	ESTSFLXA	MTVRFLXA	\$	210.77	\$	4,425.72	0.000711
ESTSFLXA	ESTSFLXA	MTDRFLXA	\$	86.39	\$	1,178.36	0.000711
ESTSFLXA	ESTSFLXA	TVRSFLXA	\$	86.39	\$	1,178.36	0.000711

ESTSFLXA	ESTSFLXA	UMTLFLXA	\$	86.39	\$	1,178.36	0.000711
OCNFFLXA	OCNFFLXA	CITRFLXA	\$	326.58	\$	7,080.06	0.000711
OCNFFLXA	OCNFFLXA	DNLNFLXA	\$	363.56	\$	8,258.42	0.000711
OCNFFLXA	OCNFFLXA	OCALFLXC	\$	138.82	\$	3,247.36	0.000711
OCNFFLXA	OCNFFLXA	LDLKFLXB	\$	307.76	\$	7,375.47	0.000711
OCNFFLXA	OCNFFLXA	MCINFLXA	\$	326.58	\$	7,080.06	0.000711
OCNFFLXA	OCNFFLXA	OCALFLXA	\$	202.19	\$	4,425.72	0.000711
OCNFFLXA	OCNFFLXA	OKLWFLXA	\$	247.76	\$	5,604.09	0.000711
OCNFFLXA	OCNFFLXA	ORSPFLXA	\$	326.58	\$	7,080.06	0.000711
OCNFFLXA	OCNFFLXA	SSPRFLXA	\$	345.60	\$	8,760.35	0.000711
OCNFFLXA	OCNFFLXA	SVSSFLXA	\$	247.76	\$	5,604.09	0.000711
FTMDFLXA	FTMDFLXA	BARTFLXA	\$	71.95	\$	1,178.36	0.000711
FTMDFLXA	FTMDFLXA	LKLDLFLXA	\$	71.95	\$	1,178.36	0.000711
RGAPFLXA	RGAPFLXA	FTMYFLXC	\$	158.34	\$	2,949.75	0.000711
FTMYFLXA	FTMYFLXA	FTMBFLXA	\$	71.95	\$	1,178.36	0.000711
FTMYFLXA	FTMYFLXA	LHACFLXA	\$	86.39	\$	1,178.36	0.000711
FTMYFLXA	FTMYFLXA	CPCRFLXB	\$	136.41	\$	2,771.35	0.000711
FTMYFLXA	FTMYFLXA	NFMYFLXA	\$	136.41	\$	2,771.35	0.000711
FTMYFLXA	FTMYFLXA	PNISFLXA	\$	71.95	\$	1,178.36	0.000711
FTMYFLXA	FTMYFLXA	SNISFLXA	\$	71.95	\$	1,178.36	0.000711
FTMBFLXA	FTMBFLXA	LHACFLXA	\$	131.95	\$	2,356.73	0.000711
FTMBFLXA	FTMBFLXA	CPCRFLXB	\$	174.82	\$	3,949.71	0.000711
FTMBFLXA	FTMBFLXA	NFMYFLXA	\$	71.95	\$	1,178.36	0.000711
FTMBFLXA	FTMBFLXA	PNISFLXA	\$	71.95	\$	1,178.36	0.000711
FTMBFLXA	FTMBFLXA	SNISFLXA	\$	71.95	\$	1,178.36	0.000711
FTWBFLXA	FTWBFLXA	HLNVFLMA *	\$	71.95	\$	1,178.36	0.000711
FTWBFLXA	FTWBFLXA	VLPFLXA	\$	86.39	\$	1,178.36	0.000711
FTWBFLXA	FTWBFLXA	SNRSFLXA	\$	149.76	\$	2,356.73	0.000711
FTWBFLXA	FTWBFLXA	SHLMFLXA	\$	86.39	\$	1,178.36	0.000711
FTWBFLXA	FTWBFLXA	VLPFLXA	\$	86.39	\$	1,178.36	0.000711
GLGCFLXA	GLGCFLXA	MOISFLXA	\$	86.39	\$	1,178.36	0.000711
GLGCFLXA	GLGCFLXA	NPLSFLXA	\$	86.39	\$	1,178.36	0.000711
GLGCFLXA	GLGCFLXA	NPLSFLXD	\$	86.39	\$	1,178.36	0.000711
GLGCFLXA	GLGCFLXA	NPLSFLXC	\$	86.39	\$	1,178.36	0.000711
GLGCFLXA	GLGCFLXA	NNPLFLXA	\$	86.39	\$	1,178.36	0.000711
GLRDFLXA	GLRDFLXA	CLBRFLAD	\$	174.14	\$	3,535.09	0.000711
GLRDFLXA	GLRDFLXA	EORNFLXA	\$	131.95	\$	2,356.73	0.000711
GLRDFLXA	GLRDFLXA	GENVFLXA	\$	131.95	\$	2,356.73	0.000711
GLRDFLXA	GLRDFLXA	LKBRFLXA	\$	131.95	\$	2,356.73	0.000711
GLRDFLXA	GLRDFLXA	LKBNFLXA	\$	174.14	\$	3,535.09	0.000711
GLRDFLXA	GLRDFLXA	MTLDLFLXA	\$	131.95	\$	2,356.73	0.000711
GLRDFLXA	GLRDFLXA	MTVRFLXA	\$	256.34	\$	5,604.09	0.000711
GLRDFLXA	GLRDFLXA	ORLDFLXA	\$	131.95	\$	2,356.73	0.000711
GLRDFLXA	GLRDFLXA	OVIDFLCA	\$	131.95	\$	2,356.73	0.000711



GLRDFLXA	GLRDFLXA	KSSMFLXC	\$	191.95	\$	3,535.09	0.000711
GLRDFLXA	GLRDFLXA	SNFRFLMA	\$	131.95	\$	2,356.73	0.000711
GLRDFLXA	GLRDFLXA	WNDRFLXA	\$	191.95	\$	3,535.09	0.000711
GLRDFLXA	GLRDFLXA	WNGRFLXA	\$	131.95	\$	2,356.73	0.000711
GLRDFLXA	GLRDFLXA	WNPKFLXA	\$	86.39	\$	1,178.36	0.000711
GDRGFLXA	GDRGFLXA	MRNNFLXA	\$	86.39	\$	1,178.36	0.000711
GDRGFLXA	GDRGFLXA	SNDSFLXA	\$	86.39	\$	1,178.36	0.000711
GNVFLXA	GNVFLXA	LEE_FLXA	\$	196.34	\$	5,018.74	0.000711
GNVFLXA	GNVFLXA	MDSNFLXA	\$	124.39	\$	3,247.36	0.000711
GNVFLXA	GNVFLXA	MNTIFLXA	\$	138.82	\$	2,654.34	0.000711
GNVFLXA	GNVFLXA	TLHSFLXA	\$	138.82	\$	2,654.34	0.000711
GNWDFLXA	GNWDFLXA	MALNFLXA	\$	86.39	\$	1,178.36	0.000711
GNWDFLXA	GNWDFLXA	MRNNFLXA	\$	86.39	\$	1,178.36	0.000711
GVLDLXA	GVLDLXA	HOWYFLXA	\$	263.21	\$	5,901.70	0.000711
GVLDLXA	GVLDLXA	LDLKFLXA	\$	202.19	\$	4,425.72	0.000711
GVLDLXA	GVLDLXA	LSBGFLXA	\$	138.82	\$	2,654.34	0.000711
GVLDLXA	GVLDLXA	MTVRFLXA	\$	326.58	\$	7,080.06	0.000711
GVLDLXA	GVLDLXA	MTDRFLXA	\$	202.19	\$	3,832.70	0.000711
GVLDLXA	GVLDLXA	TVRSFLXA	\$	202.19	\$	3,832.70	0.000711
GVLDLXA	GVLDLXA	UMTLFLXA	\$	318.00	\$	7,080.06	0.000711
OCALFLXC	OCALFLXC	CITRFLXA	\$	210.77	\$	3,832.70	0.000711
OCALFLXC	OCALFLXC	DNLNFLXA	\$	247.76	\$	5,011.07	0.000711
OCALFLXC	OCALFLXC	LDLKFLXB	\$	149.76	\$	2,949.75	0.000711
OCALFLXC	OCALFLXC	MCINFLXA	\$	210.77	\$	3,832.70	0.000711
OCALFLXC	OCALFLXC	OCALFLXA	\$	86.39	\$	1,178.36	0.000711
OCALFLXC	OCALFLXC	OKLWFLXA	\$	131.95	\$	2,356.73	0.000711
OCALFLXC	OCALFLXC	ORSPFLXA	\$	210.77	\$	3,832.70	0.000711
OCALFLXC	OCALFLXC	SSPRFLXA	\$	408.97	\$	9,938.72	0.000711
OCALFLXC	OCALFLXC	OCALFLXB	\$	138.82	\$	2,654.34	0.000711
OCALFLXC	OCALFLXC	SVSPFLXA	\$	71.95	\$	1,771.38	0.000711
OCALFLXC	OCALFLXC	SVSSFLXA	\$	131.95	\$	2,356.73	0.000711
HMSPFLLXA	HMSPFLLXA	INVRFLXA	\$	188.84	\$	3,247.36	0.000711
HOWYFLXA	HOWYFLXA	LDLKFLXA	\$	210.77	\$	5,018.74	0.000711
HOWYFLXA	HOWYFLXA	LSBGFLXA	\$	210.77	\$	4,425.72	0.000711
HOWYFLXA	HOWYFLXA	MTVRFLXA	\$	335.16	\$	7,673.08	0.000711
HOWYFLXA	HOWYFLXA	MTDRFLXA	\$	210.77	\$	4,425.72	0.000711
HOWYFLXA	HOWYFLXA	TVRSFLXA	\$	210.77	\$	4,425.72	0.000711
HOWYFLXA	HOWYFLXA	UMTLFLXA	\$	326.58	\$	7,673.08	0.000711
KNVFLXA	KNVFLXA	KSSMFLXA	\$	138.82	\$	2,654.34	0.000711
KNVFLXA	KNVFLXA	STCDFLXA	\$	138.82	\$	2,654.34	0.000711
KNVFLXA	KNVFLXA	KSSMFLXB	\$	184.39	\$	3,832.70	0.000711
KGLKFLXA	KGLKFLXA	LWTYFLXA	\$	206.77	\$	5,512.99	0.000711
KGLKFLXA	KGLKFLXA	RAFRLAB	\$	278.72	\$	6,691.36	0.000711
KGLKFLXA	KGLKFLXA	STRKFLXA	\$	206.77	\$	5,512.99	0.000711

KSSMFLXA	KSSMFLXA	CLBRFLAD	\$	114.14	\$	2,356.73	0.000711
KSSMFLXA	KSSMFLXA	HNCYFLXA	\$	138.82	\$	2,654.34	0.000711
KSSMFLXA	KSSMFLXA	STCDFLXA	\$	138.82	\$	2,654.34	0.000711
KSSMFLXA	KSSMFLXA	KSSMFLXB	\$	71.95	\$	1,178.36	0.000711
LDLKFLXA	LDLKFLXA	LSBGFLXA	\$	86.39	\$	1,771.38	0.000711
LDLKFLXA	LDLKFLXA	MTVRFLXA	\$	274.14	\$	6,197.11	0.000711
LDLKFLXA	LDLKFLXA	MTDRFLXA	\$	149.76	\$	2,949.75	0.000711
LDLKFLXA	LDLKFLXA	TVRSFLXA	\$	149.76	\$	2,949.75	0.000711
LDLKFLXA	LDLKFLXA	UMTLFLXA	\$	265.56	\$	6,197.11	0.000711
LDLKFLXB	LDLKFLXB	LSBGFLXA	\$	86.39	\$	1,771.38	0.000711
LDLKFLXB	LDLKFLXB	MTVRFLXA	\$	274.14	\$	6,197.11	0.000711
LDLKFLXB	LDLKFLXB	MTDRFLXA	\$	149.76	\$	2,949.75	0.000711
LDLKFLXB	LDLKFLXB	OCALFLXA	\$	202.19	\$	4,425.72	0.000711
LDLKFLXB	LDLKFLXB	OKLWFLXA	\$	131.95	\$	2,949.75	0.000711
LDLKFLXB	LDLKFLXB	SSPRFLXA	\$	514.53	\$	12,888.46	0.000711
LDLKFLXB	LDLKFLXB	SVSSFLXA	\$	131.95	\$	2,949.75	0.000711
LDLKFLXB	LDLKFLXB	TVRSFLXA	\$	149.76	\$	2,949.75	0.000711
LDLKFLXB	LDLKFLXB	UMTLFLXA	\$	265.56	\$	6,197.11	0.000711
LKBRFLXA	LKBRFLXA	CLBRFLAD	\$	156.33	\$	3,535.09	0.000711
LKBRFLXA	LKBRFLXA	EORNFLXA	\$	114.14	\$	2,356.73	0.000711
LKBRFLXA	LKBRFLXA	GENVFLXA	\$	114.14	\$	2,356.73	0.000711
LKBRFLXA	LKBRFLXA	LKBNFLXA	\$	156.33	\$	3,535.09	0.000711
LKBRFLXA	LKBRFLXA	MTLDFLXA	\$	71.95	\$	1,178.36	0.000711
LKBRFLXA	LKBRFLXA	MTVRFLXA	\$	238.53	\$	5,604.09	0.000711
LKBRFLXA	LKBRFLXA	ORLDFLXA	\$	114.14	\$	2,356.73	0.000711
LKBRFLXA	LKBRFLXA	OVIDFLCA	\$	114.14	\$	2,356.73	0.000711
LKBRFLXA	LKBRFLXA	KSSMFLXC	\$	174.14	\$	3,535.09	0.000711
LKBRFLXA	LKBRFLXA	SNFRFLMA	\$	114.14	\$	2,356.73	0.000711
LKBRFLXA	LKBRFLXA	WNRDFLXA	\$	174.14	\$	3,535.09	0.000711
LKBRFLXA	LKBRFLXA	WNGRFLXA	\$	114.14	\$	2,356.73	0.000711
LKBRFLXA	LKBRFLXA	WNPKFLXA	\$	71.95	\$	1,178.36	0.000711
LKHNFLXA	LKHNFLXA	ORCYFLXA	\$	71.95	\$	1,771.38	0.000711
LWTYFLXA	LWTYFLXA	RAFRFLAB	\$	278.72	\$	6,691.36	0.000711
LWTYFLXA	LWTYFLXA	STRKFLXA	\$	206.77	\$	5,512.99	0.000711
LEE_FLXA	LEE_FLXA	MDSNFLXA	\$	71.95	\$	1,771.38	0.000711
LSBGFLXA	LSBGFLXA	MTVRFLXA	\$	210.77	\$	4,425.72	0.000711
LSBGFLXA	LSBGFLXA	MTDRFLXA	\$	86.39	\$	1,178.36	0.000711
LSBGFLXA	LSBGFLXA	TVRSFLXA	\$	86.39	\$	1,178.36	0.000711
LSBGFLXA	LSBGFLXA	UMTLFLXA	\$	202.19	\$	4,425.72	0.000711
MTLDFLXA	MTLDFLXA	CLBRFLAD	\$	156.33	\$	3,535.09	0.000711
MTLDFLXA	MTLDFLXA	EORNFLXA	\$	114.14	\$	2,356.73	0.000711
MTLDFLXA	MTLDFLXA	GENVFLXA	\$	114.14	\$	2,356.73	0.000711
MTLDFLXA	MTLDFLXA	LKBNFLXA	\$	156.33	\$	3,535.09	0.000711
MTLDFLXA	MTLDFLXA	MTVRFLXA	\$	238.53	\$	5,604.09	0.000711

MTLDFLXA	MTLDFLXA	ORLDFLXA	\$	114.14	\$	2,356.73	0.000711
MTLDFLXA	MTLDFLXA	OVIDFLCA	\$	114.14	\$	2,356.73	0.000711
MTLDFLXA	MTLDFLXA	KSSMFLXC	\$	174.14	\$	3,535.09	0.000711
MTLDFLXA	MTLDFLXA	SNFRFLMA	\$	114.14	\$	2,356.73	0.000711
MTLDFLXA	MTLDFLXA	WNRFLXA	\$	174.14	\$	3,535.09	0.000711
MTLDFLXA	MTLDFLXA	WNGRFLXA	\$	114.14	\$	2,356.73	0.000711
MTLDFLXA	MTLDFLXA	WNPKFLXA	\$	71.95	\$	1,178.36	0.000711
MALNFLXA	MALNFLXA	MRNNFLXA	\$	86.39	\$	1,178.36	0.000711
MOISFLXA	MOISFLXA	NPLSFLXA	\$	86.39	\$	1,178.36	0.000711
MOISFLXA	MOISFLXA	NPLSFLXD	\$	86.39	\$	1,178.36	0.000711
MOISFLXA	MOISFLXA	NPLSFLXC	\$	86.39	\$	1,178.36	0.000711
MOISFLXA	MOISFLXA	NNPLFLXA	\$	86.39	\$	1,178.36	0.000711
MRNNFLXA	MRNNFLXA	ALTHFLXA	\$	71.95	\$	1,178.36	0.000711
MRNNFLXA	MRNNFLXA	SNDSFLXA	\$	86.39	\$	1,178.36	0.000711
MNTIFLXA	MNTIFLXA	TLHSFLXA	\$	138.82	\$	2,654.34	0.000711
MTVRFLXA	MTVRFLXA	CLBRFLAD	\$	256.34	\$	5,604.09	0.000711
MTVRFLXA	MTVRFLXA	EORNFLXA	\$	238.53	\$	5,604.09	0.000711
MTVRFLXA	MTVRFLXA	LKENFLXA	\$	256.34	\$	5,604.09	0.000711
MTVRFLXA	MTVRFLXA	MTDRFLXA	\$	210.77	\$	4,425.72	0.000711
MTVRFLXA	MTVRFLXA	ORLDFLXA	\$	238.53	\$	5,604.09	0.000711
MTVRFLXA	MTVRFLXA	KSSMFLXC	\$	210.77	\$	4,425.72	0.000711
MTVRFLXA	MTVRFLXA	TVRSFLXA	\$	210.77	\$	4,425.72	0.000711
MTVRFLXA	MTVRFLXA	UMTLFLXA	\$	210.77	\$	4,425.72	0.000711
MTVRFLXA	MTVRFLXA	WNRFLXA	\$	210.77	\$	4,425.72	0.000711
MTVRFLXA	MTVRFLXA	WNGRFLXA	\$	124.39	\$	3,247.36	0.000711
MTVRFLXA	MTVRFLXA	WNPKFLXA	\$	196.34	\$	4,425.72	0.000711
MTDRFLXA	MTDRFLXA	TVRSFLXA	\$	86.39	\$	1,178.36	0.000711
MTDRFLXA	MTDRFLXA	UMTLFLXA	\$	202.19	\$	4,425.72	0.000711
NPLSFLXA	NPLSFLXA	NPLSFLXC	\$	86.39	\$	1,178.36	0.000711
NPLSFLXA	NPLSFLXA	NNPLFLXA	\$	86.39	\$	1,178.36	0.000711
NPLSFLXD	NPLSFLXD	NPLSFLXC	\$	86.39	\$	1,178.36	0.000711
NPLSFLXD	NPLSFLXD	NNPLFLXA	\$	86.39	\$	1,178.36	0.000711
NPLSFLXC	NPLSFLXC	NNPLFLXA	\$	86.39	\$	1,178.36	0.000711
VLPRFLXA	VLPRFLXA	SHLMFLXA	\$	86.39	\$	1,178.36	0.000711
CPCRFLXB	CPCRFLXB	NFMYFLXA	\$	136.41	\$	2,771.35	0.000711
CPCRFLXB	CPCRFLXB	PNISFLXA	\$	174.82	\$	3,949.71	0.000711
CPCRFLXB	CPCRFLXB	SNISFLXA	\$	174.82	\$	3,949.71	0.000711
NFMYFLXA	NFMYFLXA	PNISFLXA	\$	71.95	\$	1,178.36	0.000711
NFMYFLXA	NFMYFLXA	SNISFLXA	\$	71.95	\$	1,178.36	0.000711
OCALFLXA	OCALFLXA	CITRFLXA	\$	263.21	\$	5,308.68	0.000711
OCALFLXA	OCALFLXA	DNLNFLXA	\$	184.39	\$	3,832.70	0.000711
OCALFLXA	OCALFLXA	MCINFLXA	\$	263.21	\$	5,308.68	0.000711
OCALFLXA	OCALFLXA	OKLWFLXA	\$	71.95	\$	1,178.36	0.000711
OCALFLXA	OCALFLXA	ORSPFLXA	\$	263.21	\$	5,308.68	0.000711

OCALFLXA	OCALFLXA	SSPRFLXA	\$	408.97	\$	9,938.72	0.000711
OCALFLXA	OCALFLXA	OCALFLXB	\$	138.82	\$	2,654.34	0.000711
OCALFLXA	OCALFLXA	SVSPFLXA	\$	158.34	\$	2,949.75	0.000711
OCALFLXA	OCALFLXA	SVSSFLXA	\$	71.95	\$	1,178.36	0.000711
OKLWFLXA	OKLWFLXA	CITRFLXA	\$	196.34	\$	3,832.70	0.000711
OKLWFLXA	OKLWFLXA	DNLNFLXA	\$	229.95	\$	5,011.07	0.000711
OKLWFLXA	OKLWFLXA	MCINFLXA	\$	196.34	\$	3,832.70	0.000711
OKLWFLXA	OKLWFLXA	ORSPFLXA	\$	196.34	\$	3,832.70	0.000711
OKLWFLXA	OKLWFLXA	SSPRFLXA	\$	454.53	\$	11,117.08	0.000711
OKLWFLXA	OKLWFLXA	SVSSFLXA	\$	71.95	\$	1,178.36	0.000711
ORCYFLXA	ORCYFLXA	DBRYFLXA	\$	71.95	\$	1,178.36	0.000711
ORCYFLXA	ORCYFLXA	DELDFLXA	\$	71.95	\$	1,178.36	0.000711
ORCYFLXA	ORCYFLXA	DLSPFLXA	\$	71.95	\$	1,178.36	0.000711
PNACFLXA	PNACFLXA	ARNPFLXA *	\$	628.66	\$	15,068.99	0.000711
PNACFLXA	PNACFLXA	SPCPFLXA	\$	395.62	\$	9,760.31	0.000711
PNACFLXA	PNACFLXA	STMKFLXA	\$	248.78	\$	6,494.72	0.000711
PNACFLXA	PNACFLXA	TLHSFLXD	\$	395.62	\$	9,760.31	0.000711
PNISFLXA	PNISFLXA	SNISFLXA	\$	71.95	\$	1,178.36	0.000711
KSSMFLXC	KSSMFLXC	CLBRFLAD	\$	131.95	\$	2,356.73	0.000711
KSSMFLXC	KSSMFLXC	EORINFLXA	\$	174.14	\$	3,535.09	0.000711
KSSMFLXC	KSSMFLXC	LKBNFLXA	\$	131.95	\$	2,356.73	0.000711
KSSMFLXC	KSSMFLXC	ORLDFLXA	\$	174.14	\$	3,535.09	0.000711
KSSMFLXC	KSSMFLXC	KSSMFLXB	\$	86.39	\$	1,178.36	0.000711
KSSMFLXC	KSSMFLXC	WNRDFLXA	\$	149.76	\$	2,356.73	0.000711
KSSMFLXC	KSSMFLXC	WNGRFLXA	\$	86.39	\$	1,178.36	0.000711
KSSMFLXC	KSSMFLXC	WNPKFLXA	\$	131.95	\$	2,356.73	0.000711
RYHLFLXA	RYHLFLXA	WSTVFLXA	\$	196.34	\$	5,018.74	0.000711
SSPRFLXA	SSPRFLXA	CITRFLXA	\$	533.35	\$	12,593.05	0.000711
SSPRFLXA	SSPRFLXA	DNLNFLXA	\$	570.34	\$	13,771.42	0.000711
SSPRFLXA	SSPRFLXA	MCINFLXA	\$	533.35	\$	12,593.05	0.000711
SSPRFLXA	SSPRFLXA	ORSPFLXA	\$	533.35	\$	12,593.05	0.000711
SSPRFLXA	SSPRFLXA	SVSSFLXA	\$	454.53	\$	11,117.08	0.000711
SNANFLXA	SNANFLXA	TLCHFLXA	\$	149.76	\$	2,356.73	0.000711
SNANFLXA	SNANFLXA	ZPHYFLXA	\$	131.95	\$	2,356.73	0.000711
SNRSFLXA	SNRSFLXA	SGBHFLXA	\$	86.39	\$	1,178.36	0.000711
SBNGFLXA	SBNGFLXA	SLHLFLXA	\$	124.39	\$	2,654.34	0.000711
SHLMFLXA	SHLMFLXA	VLPRFLXA	\$	86.39	\$	1,178.36	0.000711
SVSSFLXA	SVSSFLXA	CITFFLXA	\$	196.34	\$	3,832.70	0.000711
SVSSFLXA	SVSSFLXA	DNLNFLXA	\$	229.95	\$	5,011.07	0.000711
SVSSFLXA	SVSSFLXA	MCINFLXA	\$	196.34	\$	3,832.70	0.000711
SVSSFLXA	SVSSFLXA	ORSPFLXA	\$	196.34	\$	3,832.70	0.000711
SPCPFLXA	SPCPFLXA	ARNPFLXA *	\$	504.27	\$	11,821.63	0.000711
SPCPFLXA	SPCPFLXA	CRBIFLXA	\$	504.27	\$	11,821.63	0.000711
SPCPFLXA	SPCPFLXA	STMKFLXA	\$	395.62	\$	9,760.31	0.000711

SPCPFLXA	SPCPFLXA	TLHSFLXD	\$	271.23	\$	6,512.95	0.000711
STCDFLXA	STCDFLXA	CLBRFLAD	\$	114.14	\$	2,356.73	0.000711
STCDFLXA	STCDFLXA	KSSMFLXB	\$	71.95	\$	1,178.36	0.000711
STMKFLXA	STMKFLXA	ARPNFLXA *	\$	628.66	\$	15,068.99	0.000711
STMKFLXA	STMKFLXA	TLHSFLXD	\$	395.62	\$	9,760.31	0.000711
STRKFLXA	STRKFLXA	KYHGFLMA *	\$	278.72	\$	6,691.36	0.000711
STRKFLXA	STRKFLXA	RAFRFLAB	\$	278.72	\$	6,691.36	0.000711
TLHSFLXA	TLHSFLXA	ARPNFLXA *	\$	263.21	\$	5,308.68	0.000711
TLHSFLXA	TLHSFLXA	BRSTFLXA	\$	131.95	\$	2,356.73	0.000711
TLHSFLXA	TLHSFLXA	CRBLFLXA	\$	263.21	\$	5,308.68	0.000711
TLHSFLXA	TLHSFLXA	CHTHFLXA	\$	263.21	\$	5,308.68	0.000711
TLHSFLXA	TLHSFLXA	GNBOFLXA	\$	131.95	\$	2,356.73	0.000711
TLHSFLXA	TLHSFLXA	GRETFLXA	\$	131.95	\$	2,356.73	0.000711
TLHSFLXA	TLHSFLXA	HAVNFLMA	\$	131.95	\$	2,356.73	0.000711
TLHSFLXA	TLHSFLXA	HSFRFLXA *	\$	131.95	\$	2,356.73	0.000711
TLHSFLXA	TLHSFLXA	PRRYFLXA *	\$	263.21	\$	5,308.68	0.000711
TLHSFLXA	TLHSFLXA	QNCYFLXA	\$	131.95	\$	2,356.73	0.000711
TLHSFLXA	TLHSFLXA	TLHSFLXE	\$	86.39	\$	1,178.36	0.000711
TLHSFLXA	TLHSFLXA	TLHSFLXC	\$	86.39	\$	1,178.36	0.000711
TLHSFLXA	TLHSFLXA	TLHSFLXH	\$	86.39	\$	1,178.36	0.000711
TLHSFLXA	TLHSFLXA	TLHSFLXB	\$	86.39	\$	1,178.36	0.000711
TLHSFLXA	TLHSFLXA	TLHSFLXF	\$	149.76	\$	2,356.73	0.000711
TLHSFLXE	TLHSFLXE	ARPNFLXA *	\$	326.58	\$	6,487.04	0.000711
TLHSFLXE	TLHSFLXE	BRSTFLXA	\$	131.95	\$	2,356.73	0.000711
TLHSFLXE	TLHSFLXE	CRBLFLXA	\$	326.58	\$	6,487.04	0.000711
TLHSFLXE	TLHSFLXE	CHTHFLXA	\$	326.58	\$	6,487.04	0.000711
TLHSFLXE	TLHSFLXE	GNBOFLXA	\$	131.95	\$	2,356.73	0.000711
TLHSFLXE	TLHSFLXE	GRETFLXA	\$	131.95	\$	2,356.73	0.000711
TLHSFLXE	TLHSFLXE	HAVNFLMA	\$	131.95	\$	2,356.73	0.000711
TLHSFLXE	TLHSFLXE	HSFRFLXA *	\$	131.95	\$	2,356.73	0.000711
TLHSFLXE	TLHSFLXE	QNCYFLXA	\$	131.95	\$	2,356.73	0.000711
TLHSFLXE	TLHSFLXE	TLHSFLXC	\$	86.39	\$	1,178.36	0.000711
TLHSFLXE	TLHSFLXE	TLHSFLXH	\$	86.39	\$	1,178.36	0.000711
TLHSFLXE	TLHSFLXE	TLHSFLXB	\$	86.39	\$	1,178.36	0.000711
TLHSFLXE	TLHSFLXE	TLHSFLXF	\$	149.76	\$	2,356.73	0.000711
TLHSFLXC	TLHSFLXC	ARPNFLXA *	\$	326.58	\$	6,487.04	0.000711
TLHSFLXC	TLHSFLXC	BRSTFLXA	\$	131.95	\$	2,356.73	0.000711
TLHSFLXC	TLHSFLXC	CRBLFLXA	\$	326.58	\$	6,487.04	0.000711
TLHSFLXC	TLHSFLXC	CHTHFLXA	\$	326.58	\$	6,487.04	0.000711
TLHSFLXC	TLHSFLXC	GNBOFLXA	\$	131.95	\$	2,356.73	0.000711
TLHSFLXC	TLHSFLXC	GRETFLXA	\$	131.95	\$	2,356.73	0.000711
TLHSFLXC	TLHSFLXC	HAVNFLMA	\$	131.95	\$	2,356.73	0.000711
TLHSFLXC	TLHSFLXC	HSFRFLXA *	\$	131.95	\$	2,356.73	0.000711
TLHSFLXC	TLHSFLXC	QNCYFLXA	\$	131.95	\$	2,356.73	0.000711

TLHSFLXC	TLHSFLXC	TLHSFLXH	\$	86.39	\$	1,178.36	0.000711
TLHSFLXC	TLHSFLXC	TLHSFLXB	\$	86.39	\$	1,178.36	0.000711
TLHSFLXC	TLHSFLXC	TLHSFLXF	\$	149.76	\$	2,356.73	0.000711
TLHSFLXH	TLHSFLXH	ARPNFLXA *	\$	326.58	\$	6,487.04	0.000711
TLHSFLXH	TLHSFLXH	BRSTFLXA	\$	131.95	\$	2,356.73	0.000711
TLHSFLXH	TLHSFLXH	CRBLFLXA	\$	326.58	\$	6,487.04	0.000711
TLHSFLXH	TLHSFLXH	CHTHFLXA	\$	326.58	\$	6,487.04	0.000711
TLHSFLXH	TLHSFLXH	GNBOFLXA	\$	131.95	\$	2,356.73	0.000711
TLHSFLXH	TLHSFLXH	GRETFLXA	\$	131.95	\$	2,356.73	0.000711
TLHSFLXH	TLHSFLXH	HAVNFLMA	\$	131.95	\$	2,356.73	0.000711
TLHSFLXH	TLHSFLXH	HSFRFLXA *	\$	131.95	\$	2,356.73	0.000711
TLHSFLXH	TLHSFLXH	QNCYFLXA	\$	131.95	\$	2,356.73	0.000711
TLHSFLXH	TLHSFLXH	TLHSFLXB	\$	86.39	\$	1,178.36	0.000711
TLHSFLXH	TLHSFLXH	TLHSFLXF	\$	149.76	\$	2,356.73	0.000711
TLHSFLXB	TLHSFLXB	ARPNFLXA *	\$	326.58	\$	6,487.04	0.000711
TLHSFLXB	TLHSFLXB	BRSTFLXA	\$	71.95	\$	1,178.36	0.000711
TLHSFLXB	TLHSFLXB	CRBLFLXA	\$	326.58	\$	6,487.04	0.000711
TLHSFLXB	TLHSFLXB	CHTHFLXA	\$	326.58	\$	6,487.04	0.000711
TLHSFLXB	TLHSFLXB	GNBOFLXA	\$	71.95	\$	1,178.36	0.000711
TLHSFLXB	TLHSFLXB	GRETFLXA	\$	71.95	\$	1,178.36	0.000711
TLHSFLXB	TLHSFLXB	HAVNFLMA	\$	71.95	\$	1,178.36	0.000711
TLHSFLXB	TLHSFLXB	HSFRFLXA *	\$	71.95	\$	1,178.36	0.000711
TLHSFLXB	TLHSFLXB	QNCYFLXA	\$	71.95	\$	1,178.36	0.000711
TLHSFLXD	TLHSFLXD	ARPNFLXA *	\$	326.58	\$	6,487.04	0.000711
TLHSFLXD	TLHSFLXD	BRSTFLXA	\$	131.95	\$	2,356.73	0.000711
TLHSFLXD	TLHSFLXD	CRBLFLXA	\$	326.58	\$	6,487.04	0.000711
TLHSFLXD	TLHSFLXD	CHTHFLXA	\$	326.58	\$	6,487.04	0.000711
TLHSFLXD	TLHSFLXD	GNBOFLXA	\$	131.95	\$	2,356.73	0.000711
TLHSFLXD	TLHSFLXD	GRETFLXA	\$	131.95	\$	2,356.73	0.000711
TLHSFLXD	TLHSFLXD	HAVNFLMA	\$	131.95	\$	2,356.73	0.000711
TLHSFLXD	TLHSFLXD	HSFRFLXA *	\$	131.95	\$	2,356.73	0.000711
TLHSFLXD	TLHSFLXD	QNCYFLXA	\$	131.95	\$	2,356.73	0.000711
TLHSFLXD	TLHSFLXD	TLHSFLXA	\$	86.39	\$	1,178.36	0.000711
TLHSFLXD	TLHSFLXD	TLHSFLXE	\$	149.76	\$	2,356.73	0.000711
TLHSFLXD	TLHSFLXD	TLHSFLXC	\$	86.39	\$	1,178.36	0.000711
TLHSFLXD	TLHSFLXD	TLHSFLXH	\$	149.76	\$	2,356.73	0.000711
TLHSFLXD	TLHSFLXD	TLHSFLXB	\$	86.39	\$	1,178.36	0.000711
TLHSFLXD	TLHSFLXD	TLHSFLXF	\$	149.76	\$	2,356.73	0.000711
TLHSFLXF	TLHSFLXF	ARPNFLXA *	\$	389.95	\$	7,665.40	0.000711
TLHSFLXF	TLHSFLXF	BRSTFLXA	\$	131.95	\$	2,356.73	0.000711
TLHSFLXF	TLHSFLXF	CRBLFLXA	\$	389.95	\$	7,665.40	0.000711
TLHSFLXF	TLHSFLXF	CHTHFLXA	\$	389.95	\$	7,665.40	0.000711
TLHSFLXF	TLHSFLXF	GNBOFLXA	\$	131.95	\$	2,356.73	0.000711
TLHSFLXF	TLHSFLXF	GRETFLXA	\$	131.95	\$	2,356.73	0.000711

TLHSFLXF	TLHSFLXF	HAVNFLMA	\$	131.95	\$	2,356.73	0.000711
TLHSFLXF	TLHSFLXF	HSFRFLXA	\$	131.95	\$	2,356.73	0.000711
TLHSFLXF	TLHSFLXF	QNCYFLXA	\$	131.95	\$	2,356.73	0.000711
TLHSFLXF	TLHSFLXF	TLHSFLXB	\$	86.39	\$	1,178.36	0.000711
TVRSFLXA	TVRSFLXA	UMTLFLXA	\$	202.19	\$	4,425.72	0.000711
TLCHFLXA	TLCHFLXA	ZP-HYFLXA	\$	131.95	\$	2,356.73	0.000711
WCHLFLXA	WCHLFLXA	ZLSPFLXA	\$	124.39	\$	2,654.34	0.000711
KSSMFLXB	KSSMFLXB	CLBRFLAD	\$	71.95	\$	1,178.36	0.000711
KSSMFLXB	KSSMFLXB	HNCYFLXA	\$	184.39	\$	3,832.70	0.000711
WLSTFLXA	WLSTFLXA	BRSNFLMA	\$	71.95	\$	1,178.36	0.000711
WNDRFLXA	WNDRFLXA	CLBRFLAD	\$	174.14	\$	3,535.09	0.000711
WNDRFLXA	WNDRFLXA	EORNFLXA	\$	174.14	\$	3,535.09	0.000711
WNDRFLXA	WNDRFLXA	LKENFLXA	\$	174.14	\$	3,535.09	0.000711
WNDRFLXA	WNDRFLXA	ORLDFLXA	\$	174.14	\$	3,535.09	0.000711
WNDRFLXA	WNDRFLXA	WNGRFLXA	\$	86.39	\$	1,178.36	0.000711
WNDRFLXA	WNDRFLXA	WNPKFLXA	\$	131.95	\$	2,356.73	0.000711
WNGRFLXA	WNGRFLXA	CLBRFLAD	\$	131.95	\$	2,356.73	0.000711
WNGRFLXA	WNGRFLXA	EORNFLXA	\$	114.14	\$	2,356.73	0.000711
WNGRFLXA	WNGRFLXA	LKBNFLXA	\$	131.95	\$	2,356.73	0.000711
WNGRFLXA	WNGRFLXA	ORLDFLXA	\$	114.14	\$	2,356.73	0.000711
WNGRFLXA	WNGRFLXA	WNPKFLXA	\$	71.95	\$	1,178.36	0.000711
WNPKFLXA	WNPKFLXA	CLBRFLAD	\$	114.14	\$	2,356.73	0.000711
WNPKFLXA	WNPKFLXA	EOFNFLXA	\$	71.95	\$	1,178.36	0.000711
WNPKFLXA	WNPKFLXA	GENVFLXA	\$	71.95	\$	1,178.36	0.000711
WNPKFLXA	WNPKFLXA	LKBNFLXA	\$	114.14	\$	2,356.73	0.000711
WNPKFLXA	WNPKFLXA	ORLDFLXA	\$	71.95	\$	1,178.36	0.000711
WNPKFLXA	WNPKFLXA	OVIDFLCA	\$	71.95	\$	1,178.36	0.000711
WNPKFLXA	WNPKFLXA	SNFRFLMA	\$	71.95	\$	1,178.36	0.000711
WNPKFLXA	WNPKFLXA	WNPKFLXE	\$	71.95	ICB		0.000711

**Table One**



## **PART D LOCAL RESALE**

### **39. TELECOMMUNICATIONS SERVICES PROVIDED FOR RESALE**

- 39.1. At the request of CLEC, and pursuant to the requirements of the Act, and FCC and Commission Rules and Regulations, Sprint shall make available to CLEC for resale Telecommunications Services that Sprint currently provides or may provide hereafter at retail to subscribers who are not telecommunications carriers. Such resale may be as allowed by the FCC and Commission. The Telecommunications Services provided by Sprint to CLEC pursuant to this Part D are collectively referred to as "Local Resale."
- 39.2. Such resale may be as allowed by the FCC and Commission. The Telecommunications Services provided pursuant to this Part D are collectively referred to as "Local Resale."
- 39.3. To the extent that this Part describes services which Sprint shall make available to CLEC for resale pursuant to this Agreement, this list of services is neither all inclusive nor exclusive.

### **40. GENERAL TERMS AND CONDITIONS**

- 40.1. Pricing. The prices charged to CLEC for Local Resale are set forth in Part C of this Agreement.

#### **40.1.1. CENTREX Requirements**

- 40.1.1.1. At CLEC's option, CLEC may purchase the entire set of CENTREX features or a subset of any such features.
- 40.1.1.2. All features and functions of CENTREX Service, including CENTREX Management System (CMS), whether offered under tariff or otherwise, shall be available to CLEC for resale.
- 40.1.1.3. Sprint shall make information required for an "as is" transfer of CENTREX subscriber service, features, functionalities and CMS capabilities available to CLEC.
- 40.1.1.4. Consistent with Sprint's tariffs, CLEC, at its expense, may collect all data and aggregate the CENTREX local exchange, and IntraLATA traffic usage of CLEC subscribers to qualify for volume discounts on the basis of such aggregated usage.
- 40.1.1.5. CLEC may request that Sprint suppress the need for CLEC subscribers to dial "9" when placing calls outside the CENTREX System. Should CLEC request this capability for its subscriber, the subscriber will not be able to use 4-digit dialing.
- 40.1.1.6. CLEC may resell call forwarding in conjunction with

CENTREX Service.

- 40.1.1.7. CLEC may purchase any CENTREX Service for resale subject to the requirements of Sprint's tariff.
- 40.1.1.8. Sprint shall make available to CLEC for resale intercom calling within the same CENTREX system. To the extent that Sprint offers its own subscribers intercom calling between different CENTREX systems, Sprint shall make such capability available to CLEC for resale.
- 40.1.1.9. CLEC may resell Automatic Route Selection ("ARS"). CLEC may aggregate multiple CLEC subscribers on dedicated access facilities where such aggregation is allowed by law, rule or regulation.
- 40.1.2. Voluntary Federal and State Subscriber Financial Assistance Programs
- 40.1.2.1. Subsidized local Telecommunications Services are provided to low-income subscribers pursuant to requirements established by the appropriate state regulatory body, and include programs such as Voluntary Federal Subscriber Financial Assistance Program and Link-Up America. Voluntary Federal and State Subscriber Financial Assistance Programs are not Telecommunications Services that are available for resale under this Agreement. However, when a Sprint subscriber who is eligible for such a federal program or other similar state program chooses to obtain Local Resale from CLEC and CLEC serves such subscriber via Local Resale, Sprint shall identify such subscriber's eligibility to participate in such programs to CLEC in accordance with the procedures set forth herein.
- 40.1.3. Grandfathered Services. Sprint will make any service grandfathered to an end-user or any Individual Case Basis ("ICB") service available to CLEC for resale to that same end-user at the same location(s). Should Sprint discontinue any grandfathered or ICB service Sprint will provide to CLEC any legally required notice as soon as practicable and at least equal in quality and timeliness to that which is provided to Sprint's own customers, prior to the effective date of changes in or discontinuation of any product or service that is available for resale under this Subsection.
- 40.1.4. Contract Service Arrangements, Special Arrangements, and Promotions. Sprint shall offer for resale all of its Telecommunications Services available at retail to subscribers who are not Telecommunications Carriers, including but not limited to Contract Service Arrangements (or ICB), Special Arrangements (or ICB), and Promotions in excess of ninety (90) days, all in accordance with FCC and Commission Rules and Regulations.

40.1.5. COCOT lines or Pay Telephone Access Lines will be sold at wholesale prices to CLEC for the purposes of resale to third parties providing pay telephone service to the public. Provision of pay telephone service by CLEC directly to the public or resale to entities or organizations affiliated with or having the same or substantially similar identity as CLEC, using COCOT lines or Pay Telephone Access Lines purchased at wholesale, is not allowable resale under the Agreement and is a material breach of the terms of this Agreement.

40.1.6. Voice Mail Service is not a Telecommunications Service available for resale under this Agreement. However, where available, Sprint shall make available for Local Resale the SMDI-E (Station Message Desk Interface-Enhanced), or SMDI, Station Message Desk Interface where SMDI-E is not available, feature capability allowing for Voice Mail Services. Sprint shall make available the MWI (Message Waiting Indicator) interrupted dial tone and message waiting light feature capabilities where technically available. Sprint shall make available CF-B/DA (Call Forward on Busy/Don't Answer), CF/B (Call Forward on Busy), and CF/DA (Call Forward Don't Answer) feature capabilities allowing for Voice Mail services.

40.1.7. Hospitality Service. Sprint shall provide all blocking, screening, and all other applicable functions available for hospitality lines under tariff.

40.1.8. LIDB Administration

40.1.8.1. Sprint shall maintain customer information for CLEC customers who subscribe to resold Sprint local service dial tone lines, in Sprint's LIDB in the same manner that it maintains information in LIDB for its own similarly situated end-user subscribers. Sprint shall update and maintain the CLEC information in LIDB on the same schedule that it uses for its own similarly situated end-user subscribers.

40.1.8.2. Until such time as Sprint's LIDB has the software capability to recognize a resold number as CLEC's, Sprint shall store the resold number in its LIDB at no charge and shall retain revenue for LIDB look-ups to the resold number.

## **PART E NETWORK ELEMENTS**

### **41. GENERAL**

41.1. Pursuant to the following terms, Sprint will unbundle and separately price and offer Unbundled Network Elements, ("UNEs") such that CLEC will be able to subscribe to and interconnect to whichever of these unbundled elements CLEC requires for the purpose of providing local telephone service to its end users. CLEC shall pay Sprint each month for the UNEs provisioned, and shall pay the non-recurring charges listed in Part C or agreed to by the Parties. It is CLEC's obligation to combine Sprint-provided UNEs with any facilities and services that CLEC may itself provide. Sprint will continue to offer the UNEs enumerated below subject to further determinations as to which UNEs ILECs are required to offer under the Act, at which time the Parties agree to modify this section pursuant to the obligations set forth in Part B, Paragraph 3.2 of this Agreement.

### **42. UNBUNDLED NETWORK ELEMENTS**

42.1. Sprint shall offer UNEs to CLEC for the purpose of offering Telecommunication Services to CLEC subscribers. Sprint shall offer UNEs to CLEC on an unbundled basis on rates, terms and conditions that are just, reasonable, and non-discriminatory in accordance with the terms and conditions of this Agreement. The initial set of UNEs include:

42.1.1. Network Interface Device ("NID")

42.1.2. Local Loop

42.1.3. Sub loop

42.1.4. Switching Capability (Except for switching used to serve end users with four or more lines in access density zone 1, in the top 50 Metropolitan Statistical Areas where Sprint provides non-discriminatory access to the enhanced extended link.)

42.1.4.1 Local Switching

42.1.4.2 Tandem Switching

42.1.5 Interoffice Transport Facilities

42.1.5.1 Common

42.1.5.2 Dedicated

42.1.6 Signaling Networks & Call Related Databases

42.1.7 Operations Support Systems

42.2. CLEC may use one or more UNEs to provide any feature, function, capability, or

service option that such UNE(s) is (are) technically capable of providing. It is CLEC's obligation to combine Sprint-provided UNEs with any and all facilities and services whether provided by Sprint, CLEC, or any other party.

- 42.3. Each UNE provided by Sprint to CLEC shall be at Parity with the quality of design, performance, features, functions, capabilities and other characteristics, including but not limited to levels and types of redundant equipment and facilities for power, diversity and security, that Sprint provides to itself, Sprint's own subscribers, to a Sprint Affiliate or to any other entity.

#### **43. BONA FIDE REQUEST PROCESS FOR FURTHER UNBUNDLING**

- 43.1. Each Party shall promptly consider and analyze access to categories of UNE not covered in this Agreement with the submission of a Network Element Bona Fide Request hereunder. The UNE Bona Fide Request process set forth herein does not apply to those services requested pursuant to FCC Rule § 51.319, as amended.
- 43.2. A UNE Bona Fide Request shall be submitted in writing on the Sprint LTD Standard BFR Form and shall include a technical description of each requested UNE.
- 43.3. The requesting Party may cancel a UNE Bona Fide Request at any time, but shall pay the other Party's reasonable and demonstrable costs of processing and/or implementing the UNE Bona Fide Request up to the date of cancellation.
- 43.4. Within ten (10) business days of its receipt, the receiving Party shall acknowledge receipt of the UNE Bona Fide Request.
- 43.5. Except under extraordinary circumstances, within thirty (30) days of its receipt of a UNE Bona Fide Request, the receiving Party shall provide to the requesting Party a preliminary analysis of such UNE Bona Fide Request. The preliminary analysis shall confirm that the receiving Party will offer access to the UNE or will provide a detailed explanation that access to the UNE does not qualify as a UNE that is required to be provided under the Act.
- 43.6. Upon receipt of the preliminary analysis, the requesting Party shall, within thirty (30) days, notify the receiving Party, in writing, of its intent to proceed or not to proceed.
- 43.7. The receiving Party shall promptly proceed with the UNE Bona Fide Request upon receipt of written authorization from the requesting Party. When it receives such authorization, the receiving Party shall promptly develop the requested services, determine their availability, calculate the applicable prices and establish installation intervals.
- 43.8. As soon as feasible, but not more than ninety (90) days after its receipt of authorization to proceed with developing the UNE Bona Fide Request, the receiving Party shall provide to the requesting Party a UNE Bona Fide Request

Quote which will include, at a minimum, a description of each UNE, the availability, the applicable rates and the installation intervals.

- 43.9. Within thirty (30) days of its receipt of the UNE Bona Fide Request Quote, the requesting Party must either confirm, in writing, its order for the UNE Bona Fide Request pursuant to the UNE Bona Fide Request Quote or if a disagreement arises, seek resolution of the dispute under the Dispute Resolution procedures of this Agreement.
- 43.10. If a Party to a UNE Bona Fide Request believes that the other Party is not requesting, negotiating or processing the UNE Bona Fide Request in good faith, or disputes a determination, or price or cost quote, such Party may seek resolution of the dispute pursuant to the Dispute Resolution provisions of this Agreement.

#### **44. NETWORK INTERFACE DEVICE**

- 44.1. Sprint will offer unbundled access to NIDs. The NID includes any potential means of interconnection with customer premises inside wiring at the point where the carrier's local loop facilities end, such as at a cross connect device used to connect the loop to customer-controlled inside wiring. This includes all features, functions, and capabilities of the facilities used to connect the loop to premises wiring, regardless of the specific mechanical design.
- 44.2. The function of the NID is to establish the network demarcation point between a CLEC and its subscriber. The NID provides a protective ground connection, protection against lightning and other high voltage surges and is capable of terminating cables such as twisted pair cable.
- 44.3. CLEC may connect its NID to Sprint's NID; may connect an unbundled loop to its NID; or may connect its own Loop to Sprint's NID. Sprint will provide one NID termination for each loop. If additional NID terminations are required, CLEC may request them pursuant to process detailed in Article 44 herein.
- 44.4. Sprint will provide CLEC with information that will enable their technician to locate end user inside wiring at NIDs terminating multiple subscribers. Sprint will dispatch a technician and tag the wiring at the CLECs request. In such cases the charges specified in Part C will apply.
- 44.5. Sprint will not provide specialized (Sprint non-standard) NIDs.
- 44.6. The Sprint NID shall provide a clean, accessible point of connection for the inside wiring and for the Distribution Media and/or cross connect to CLEC's NID and shall maintain a connection to ground that meets the requirements set forth below. Each party shall ground its NID independently of the other party's NID.

#### **45. LOOP**

- 45.1. The definition of the loop network element includes all features, functions, and

capabilities of the transmission facilities, including dark fiber and attached electronics (except those used for the provision of advanced services, such as DSLAMs) owned by Sprint, between a Sprint central office and the loop demarcation point at the customer premises. Terms and conditions for the provision of dark fiber have not yet been determined, however, the Parties will negotiate in good faith to reach mutually acceptable terms and conditions. The demarcation point is that point on the loop where the telephone company's control of the wire ceases, and the subscriber's control (or, in the case of some multiunit premises, the landlord's control) of the wire begins. This includes, but is not limited to, two-wire and four-wire copper analog voice-grade loops and two-wire and four-wire conditioned loops.

- 45.2. Conditioned Loops. Sprint will condition loops at CLECs request. Conditioned loops are copper loops from which excessive bridge taps, load coils, low-pass filters, range extenders, and similar devices have been removed to enable the delivery of high-speed wireline telecommunications capability, including xDSL. Sprint will assess charges for loop conditioning in accordance with the prices listed in Part C.
- 45.3. At CLECs request, and if technically feasible, Sprint will test and report trouble on conditioned loops for all of the line's features, functions, and capabilities, and will not restrict its testing to voice-transmission only.
  - 45.3.1. Basic testing does not include cooperative efforts that require Sprint's technician to work jointly with CLECs staff.
  - 45.3.2. Cooperative testing will be provided by Sprint at CLECs expense. Sprint technicians will try to contact CLECs representative at the conclusion of installation. If the CLEC does not respond within 5 minutes, Sprint may abandon the test and CLEC will still be charged a cooperative test charge.
  - 45.3.3. Sprint will charge CLEC at the rates set out in Part C, when the location of the trouble on a CLEC reported ticket is determined to be in CLECs network.
- 45.4. Voice Grade Loop Capabilities
  - 45.4.1. Voice grade loops are analog loops that facilitate the transmission of analog voice grade signals in the 300-3000 Hz range and terminates in a 2-wire or 4-wire electrical interface at the CLECs customer's premises. CLEC shall not install equipment on analog loops that exceeds the specified bandwidth.
  - 45.4.2. If Sprint uses Digital Loop Carrier or other similar remote concentration devices, and if facilities are available, Sprint will make alternative arrangements at CLEC's request and option, to provide an unbundled voice grade loop. Alternative arrangements may include existing copper facilities or provisioning through the DSL where capabilities exist.

45.4.3. Where facilities are not available, CLEC requests will be processed through the BFR process. CLEC agrees to reimburse Sprint for the actual cost of the modifications necessary to make the alternative arrangements available.

#### 45.5. Non-Voice Grade Loops

45.5.1. Sprint will provide non-voice grade loops on the basis of the service that will be provisioned over the loop. Sprint requires CLEC to provide in writing (via the service order) the spectrum management class as defined in T1E1.4/99-002R6 draft desired in a particular loop (e.g., ISDN-BRI, PRI, ADSL, HDSL, DS1, etc.) so that the loop may be engineered to meet the appropriate spectrum compatibility requirements. CLEC must disclose to Sprint every Spectrum Management Class (SMC) that the CLEC has implemented on its facilities to permit effective Spectrum Management. If CLEC requires a change in the SMC of a particular loop, (e.g., changing from ISDN service to ADSL), CLEC shall notify Sprint in writing of the requested change in the SMC (via a service order). If Sprint finds that it is not technically feasible, or not in accordance with effective Spectrum Management, to provide the new level of service to CLEC, Sprint will notify CLEC that it is unable to meet the request. On non-voice grade loops, both standard and non-standard, Sprint will only provide electrical continuity and line balance.

45.5.2. If Sprint uses Digital Loop Carrier or other similar remote concentration devices, and if facilities are available, Sprint will make alternative arrangements at CLEC's request and option, to provide an unbundled nonvoice grade loop. Alternative arrangements may include copper existing facilities, or dedicated transmission equipment or provisioning through the DSL where capacities exist.

45.5.3. Where facilities are not available, CLEC requests will be processed through the BFR process. CLEC agrees to reimburse Sprint for the actual cost of the modifications necessary to make the alternative arrangements available.

45.5.4. CLEC will submit a BFR for non-voice grade loops that are not currently price-listed.

45.5.5. Reverse ADSL Loops. All DSL ATU-C units in Sprint's network, including those integrated into DSLAMs, should either reside within a Sprint host or remote central office. If an ADSL copper loop should start at an outside location, and is looped through a host or remote, and then to the subscriber, the copper plant from the outside location to the Sprint host or remote central office must be a facility dedicated to ADSL transmission only and not part of Sprint's regular feeder or distribution plant.

45.5.6. CLEC shall meet the power spectral density requirement given in the



respective technical references listed below:

45.5.6.1. For Basic Rate ISDN: Telcordia TR-NWT-000393 Generic Requirements for ISDN Basic Access Digital Subscriber Lines.

45.5.6.2. For HDSL installations: Telcordia TA-NWT-001210 Generic Requirements for High-Bit-Rate Digital Subscriber Lines. Some fractional T1 derived products operating at 768 kbps may use the same standard.

45.5.6.3. For ADSL: ANSI T1.413-1995 (Issue 2 and subsequent revisions) Asymmetrical Digital Subscriber Line (ADSL) Metallic Interface. Sprint does not permit the Power Boost option used in its local network.

#### 45.6. Non-Standard Non-Voice Grade Loops

45.6.1. If CLEC requests an ADSL loop, for which the effective loop length exceeds the ADSL standard of 18 kft (subject to gauge design used in an area), Sprint will only provide a Non-Standard Data Line. Additional non-recurring charges for engineering and load coil removal will apply, plus trip charges and any applicable maintenance charges. Non-Standard Data Lines will not be subject to performance measurements or technical specifications.

#### 45.7. Adherence to National Industry Standards

45.7.1. To the extent that CLEC chooses to use technologies not conforming with standards noted above, but whose characteristics are approved by an industry standards body (ANSI, Telcordia), CLEC agrees to provide Sprint with test results from previous field trials, lab tests, and actual commercial deployment in other markets. CLEC will work with Sprint at Sprint's option to jointly test or evaluate the use of the technology in Sprint's technology assessment body and in its plant in a controlled field trial basis prior to general deployment. CLEC will provide previous deployment data to Sprint that will also include the deployment volumes of the technology; any spectral problems and how they were resolved; non-stationary signals; and short term stationary signals if applicable. Based upon the results of the joint testing and other evaluation information available to Sprint, and assuming such information satisfies Sprint that such deployment will not damage or interfere with the operation of Sprint's network, unless tested and agreed to by the Parties during the field trial, the deployment of such technology will be approved but constrained to the same deployment limits established in the successful deployment in other markets.

45.7.2. As an alternative to 45.7.1 CLEC may meet the requirements given in ANSI document T1E1.4/99-002R5 dated October 5, 1999. "Working

Draft of Spectrum Management Standard", and subsequent revisions of this document.

- 45.7.3. Parties agree to abide by national standards as developed by ANSI, i.e. Committee T1E1.4 group defining standards for loop technology. At the time the deployed technology is standardized by ANSI or the recognized standards body, the CLEC will upgrade its equipment to the adopted standard within 60 days of the standard being adopted
- 45.7.4. To the extent that CLEC chooses to use technologies not conforming with standards noted above, and whose characteristics have not been approved by a standards body but has been successfully deployed by CLEC, CLEC agrees to provide Sprint with test results from previous field trials, lab tests, and actual commercial deployment in other markets. Further, CLEC agrees to work with Sprint to jointly test and evaluate the use of the technology in a controlled field trial to evaluate the use of the technology prior to general deployment in Sprint's network. Based upon the results of the joint testing and other evaluation information available to Sprint and assuming such information satisfies Sprint that such deployment will not damage or interfere with the operation of Sprint's network, unless tested and agreed to by the Parties during the field trial, the deployment of such technology will be approved but constrained to the same deployment limits established in the successful deployment in other markets.

#### 45.8. Interference

- 45.8.1. The parties agree that it is important to work together to mitigate the potential of interference in their respective networks that may be caused by the use of advanced service technologies.
- 45.8.2. Prior to CLEC provisioning of service over an xDSL-capable loop, if Sprint determines, after the joint testing or evaluation described in 45.4.3 above, in its reasonable discretion that use of such technology will cause interference with the services of Sprint or others using Sprint's plant, Sprint will give notice to CLEC as soon as possible. The parties will cooperate in trying to resolve the issue related to such interference. In the event the Parties are unable to agree, Sprint will promptly file its objections with the Commission and/or designated problem resolution body, and seek an expedited resolution. Provisioning of such service will be held in abeyance pending resolution of the action at the Commission.
- 45.8.3. If, after CLEC commences providing service over xDSL-capable or other non-voice grade loops, this service causes interference to other services, CLEC agrees to quickly respond to develop a mutually agreeable resolution to eliminate the interference problem.
- 45.8.4. If in its reasonable determination Sprint finds that CLEC is causing interference and has not taken prompt steps to eliminate the interference

problem, Sprint reserves the right to suspend the particular service. Sprint will notify CLEC prior to suspension of service. Such suspension will be promptly followed by a request for Commission intervention subject to Section XIX Dispute Resolution.

#### **46. SUBLOOPS.**

- 46.1. Sprint will offer unbundled access to subloops, or portions of the loop, at any accessible terminal in Sprint's outside loop plant. Such locations include, for example, a pole or pedestal, the network interface device, the minimum point of entry to the customer premises, and the feeder distribution interface located in, for example, a utility room, a remote terminal, a controlled environment vault or at the MDF.
- 46.2. An accessible terminal is any point on the loop where technicians can access the wire or fiber within the cable (i.e., via screw posts, terminals, patch panels) without removing a splice cased to reach the wire or fiber within.
- 46.3. Initially Sprint will consider all requests for access to subloops on an individual case basis due to the wide variety of interconnections available and the lack of standards and provide written response to CLEC covering time intervals, prices and other information based on the BFR process. Typical arrangements and corresponding prices will be developed after a substantial number have been provided and a pattern exists.

#### **47. LOCAL SWITCHING**

- 47.1. Local Switching is the Network Element that provides the functionality required to connect the appropriate lines or trunks wired to the Main Distributing Frame (MDF) or Digital Cross Connect (DSX) panel to a desired line or trunk. Such functionality shall include all of the features, functions, and capabilities that the underlying Sprint switch providing such Local Switching function provides for Sprint's own services. Functionality may include, but is not limited to: line signaling and signaling software, digit reception, dialed number translations, call screening, routing, recording, call supervision, dial tone, switching, telephone number provisioning, announcements, calling features and capabilities (including call processing), Centrex, or Centrex like services, Automatic Call Distributor (ACD), CLEC pre-subscription (e.g., long distance Carrier, intraLATA toll), Carrier Identification Code (CIC) portability capabilities, testing and other operational features inherent to the switch and switch software. Anything else in this Agreement notwithstanding, Sprint is not required to provide local switching under this Article 45 for switching used to serve end users with four or more lines in access density zone 1, in the top 50 Metropolitan Statistical Areas where Sprint provides non-discriminatory access to the enhanced extended link.
- 47.2. Sprint will provide customized routing at CLECs request where technically feasible. Customized routing enables the CLEC to route their customer's traffic

differently than normally provided by Sprint. For example, customized routing will allow the CLEC to route their customer's operator handled traffic to a different provider. , CLEC requests will be processed through the BFR process. Pricing will be on a time and materials basis.

#### 47.3. Technical Requirements

47.3.1. Sprint shall provide its standard recorded announcements (as designated by CLEC) and call progress tones to alert callers of call progress and disposition. CLEC will use the BFR process for unique announcements.

47.3.2. Sprint shall change a subscriber from Sprint's Telecommunications Services to CLEC's Telecommunications Services without loss of feature functionality unless expressly agreed otherwise by CLEC.

47.3.3. Sprint shall control congestion points such as mass calling events, and network routing abnormalities, using capabilities such as Automatic Call Gapping, Automatic Congestion Control, and Network Routing Overflow. Application of such control shall be competitively neutral and not favor any user of unbundled switching or Sprint.

47.3.4. Sprint shall offer all Local Switching features that are technically feasible and provide feature offerings at Parity with those provided by Sprint to itself or any other party.

#### 47.4. Interface Requirements. Sprint shall provide the following interfaces:

47.4.1. Standard Tip/Ring interface including loopstart or groundstart, on-hook signaling (e.g.: for calling number, calling name and message waiting lamp);

47.4.2. Coin phone signaling;

47.4.3. Basic and Primary Rate Interface ISDN adhering to ANSI standards Q.931, Q.932 and appropriate Telcordia Technical Requirements;

47.4.4. Two-wire analog interface to PBX to include reverse battery, E&M, wink start and DID;

47.4.5. Four-wire analog interface to PBX to include reverse battery, E&M, wink start and DID; and

47.4.6. Four-wire DS1 interface to PBX or subscriber provided equipment (e.g., computers and voice response systems).

### 48. TANDEM SWITCHING

48.1. Tandem Switching is the function that establishes a communications path between two switching offices (connecting trunks to trunks) through a third switching office (the tandem switch) including but not limited to CLEC, Sprint, independent

telephone companies, IXC's and wireless Carriers. A host/remote end office configuration is not a Tandem Switching arrangement. Anything else in this Agreement notwithstanding, Sprint is not required to provide tandem switching under this Article 48 for switching used to serve end users with four or more lines in access density zone 1, in the top 50 Metropolitan Statistical Areas where Sprint provides non-discriminatory access to the enhanced extended link.

#### 48.2. Technical Requirements

48.2.1. The requirements for Tandem Switching include, but are not limited to, the following:

48.2.1.1. Interconnection to Sprint tandem(s) will provide CLEC local interconnection for local and toll access service purposes to the Sprint end offices and NXXs which interconnect with that tandem(s) either directly or through other Sprint facilities for local and toll service purposes, and to other companies which are likewise connected to that tandem(s).

48.2.1.2. Interconnection to a Sprint tandem for transit purposes will provide CLEC interexchange access to Sprint IXC's, other local carriers, ILEC's, and CMRS providers which are connected to that tandem.

48.2.1.3. Where a Sprint Tandem Switch also provides End-Office Switch functions, interconnection to a Sprint tandem serving that exchange will also provide CLEC access to Sprint's end offices.

48.2.2. Tandem Switching shall preserve CLASS/LASS features and Caller ID as traffic is processed.

48.2.3. To the extent technically feasible, Tandem Switching shall record billable events for distribution to the billing center designated by CLEC.

48.2.4. Tandem Switching shall control congestion using capabilities such as Automatic Congestion Control and Network Routing Overflow. Congestion control provided or imposed on CLEC traffic shall be at Parity with controls being provided or imposed on Sprint traffic (e.g., Sprint shall not block CLEC traffic and leave its traffic unaffected or less affected).

48.2.5. The Local Switching and Tandem Switching functions may be combined in an office. If this is done, both Local Switching and Tandem Switching shall provide all of the functionality required of each of those Network Elements in this Agreement.

48.2.6. Tandem Switching shall provide interconnection to the E911 PSAP where the underlying Tandem is acting as the E911 Tandem.

#### 48.3. Interface Requirements

48.3.1. Direct trunks will be utilized for interconnection to Sprint Tandems, excluding transit traffic via common trunks as may be required under the Act.

48.3.2. Sprint shall provide all signaling necessary to provide Tandem Switching with no loss of feature functionality.

## **49. TRANSPORT**

49.1. Shared Transport Sprint will offer unbundled access to shared transport where unbundled local circuit switching is provided. Shared transport is defined as transmission facilities shared by more than one carrier, including Sprint, between end office switches, between end office switches and tandem switches, and between tandem switches in the Sprint network.

49.1.1. Shared Transport provides a local interoffice transmission path between the Sprint tandem switch and a Sprint or CLEC end office switch, or between a host in one rate center and a remote in another rate center. Shared Transport is shared between multiple carriers and is required to be switched at the tandem.

49.1.2. Sprint may provide Shared Transport at DS-0, DS-1, DS-3, STS-1 or higher transmission bit rate circuits.

49.1.3. Sprint shall be responsible for the engineering, provisioning, and maintenance of the underlying Sprint equipment and facilities that are used to provide Shared Transport.

49.2. Dedicated Transport. Sprint will offer unbundled access to dedicated interoffice transmission facilities, or transport, including dark fiber. Terms and conditions for providing dark fiber have not yet been determined. Dedicated interoffice transmission facilities are defined as Sprint transmission facilities dedicated to a particular customer or carrier that provide telecommunications between wire centers owned by Sprint or requesting telecommunications carriers, or between switches owned by Sprint or requesting telecommunications carriers. Sprint may impose reasonable limits governing access to dark fiber to the extent that Sprint needs to maintain fiber reserves.

49.2.1. Dedicated Transport provides a local interoffice transmission path between Sprint and/or CLEC central offices. Dedicated transport is limited to the use of a single carrier and does not require switching at a tandem.

49.2.2. Technical Requirements

49.2.2.1. Where technologically feasible and available, Sprint shall offer Dedicated Transport consistent with the underlying technology as follows:

49.2.2.2. When Sprint provides Dedicated Transport, the entire designated transmission circuit (e.g.: DS-1, DS-3, STS-1) shall be dedicated to CLEC designated traffic.

49.2.2.3. Where Sprint has technology available, Sprint shall offer Dedicated Transport using currently available technologies including, but not limited to, DS1 and DS3 transport systems, SONET (or SDH) Bi-directional Line Switched Rings, SONET (or SDH) Unidirectional Path Switched Rings, and SONET (or SDH) point-to-point transport systems (including linear add-drop systems), at all available transmission bit rates.

## **50. SIGNALING SYSTEMS AND DATABASES**

50.1. Sprint will offer unbundled access to signaling links and signaling transfer points (STPs) in conjunction with unbundled switching, and on a stand-alone basis. The signaling network element includes, but is not limited to, signaling links and STPs. Sprint will offer unbundled access to call-related databases, including, but not limited to, the Line Information database (LIDB), Toll Free Calling database, Number Portability database, Calling Name (CNAM) database, Operator Services/Directory Assistance databases, Advanced Intelligent Network (AIN) databases, and the AIN platform and architecture. Sprint reserves the right to decline to offer unbundled access to certain AIN software that qualifies for proprietary treatment.

### **50.2. Signaling Systems**

#### **50.2.1. Signaling Link Transport**

50.2.1.1. Signaling Link Transport is a set of two or four dedicated 56 Kbps transmission paths between CLEC-designated Signaling Points of Interconnection (SPOI) that provides appropriate physical diversity and a cross connect at a Sprint STP site.

50.2.1.2. Technical Requirements. Signaling Link Transport shall consist of full duplex mode 56 Kbps transmission paths.

#### **50.2.2. Signaling Transfer Points (STPs)**

50.2.2.1. Signaling Transfer Points (STPs) provide functionality that enable the exchange of SS7 messages among and between switching elements, database elements and signaling transfer points.

50.2.2.2. Figure 2 depicts Signaling Transfer Points.

## Signaling Transfer Points.

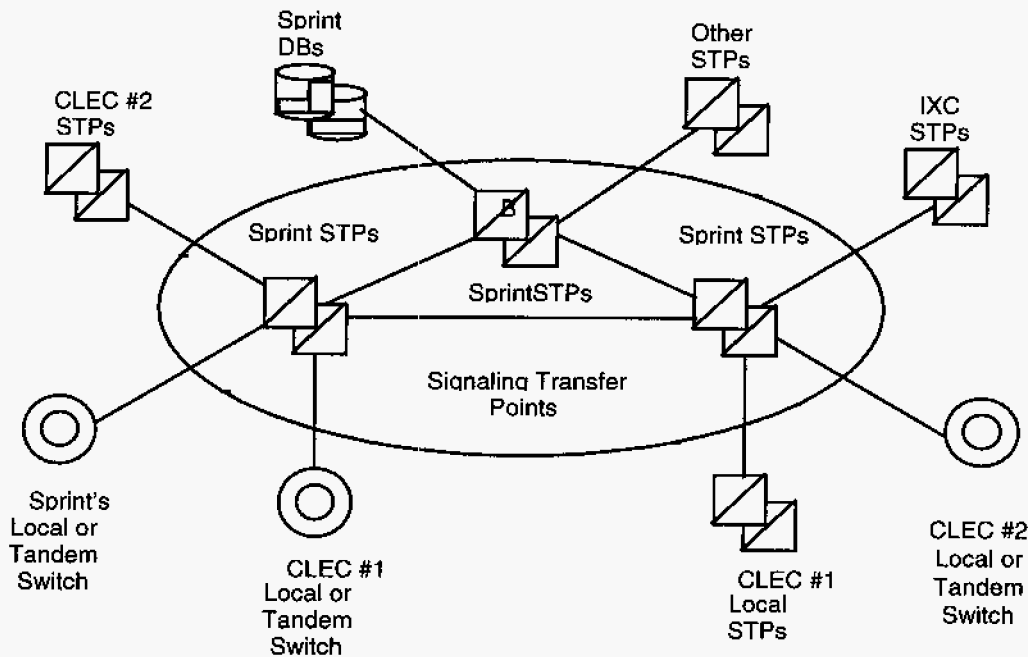

**Figure 2**

50.2.2.3. Technical Requirements. STPs shall provide access to and fully support the functions of all other Network Elements connected to the Sprint SS7 network. These include:

- 50.2.2.3.1. Sprint Local Switching or Tandem Switching;
- 50.2.2.3.2. Sprint Service Control Points/DataBases;
- 50.2.2.3.3. Third-party local or Tandem Switching systems;  
and
- 50.2.2.3.4. Third-party-provided STPs.

50.2.2.4. Interface Requirements: Sprint shall provide the following STP options to connect CLEC or CLEC-designated local switching systems or STPs to the Sprint SS7 network:

- 50.2.2.4.1. An A-link interface from CLEC local switching systems; and



50.2.2.4.2. B or D-link interface from CLEC STPs.

50.2.2.4.3. Each type of interface shall be provided by one or more sets (layers) of signaling links, as follows:

50.2.2.4.4. An A-link layer shall consist of two links, as depicted in Figure 3.

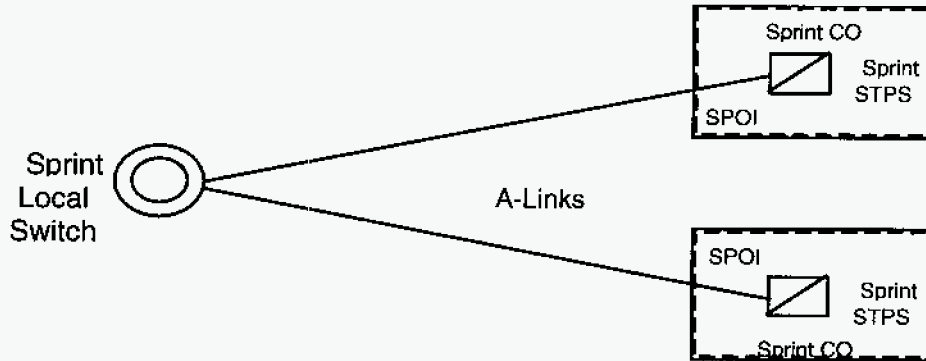

**Figure 3. A-Link Interface**

50.2.2.4.5. A B or D-link layer shall consist of four links, as depicted in Figure 4.

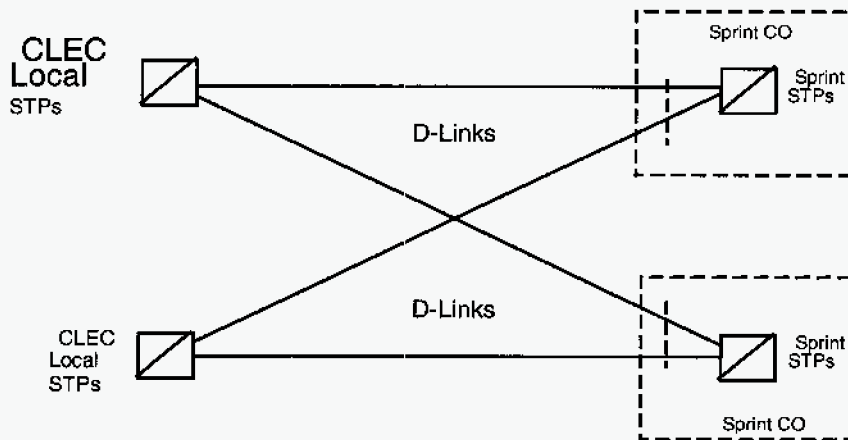

**Figure 4. D-Link Interface**

50.2.2.4.6. Signaling Point of Interconnection (SPOI) for each link shall be located at a cross-connect element, such as a DSX-1, in the Central Office (CO) where the Sprint STPs is located. Interface to Sprint's STP shall be the 56kb rate.

The 56kb rate can be part of a larger facility, and CLEC shall pay multiplexing/demultiplexing and channel termination, plus mileage of any leased facility.

### 50.3. Line Information Database (LIDB)

50.3.1. The LIDB is a transaction-oriented database accessible CCS networks. It contains records associated with subscribers Line Numbers and Special Billing Numbers. LIDB accepts queries from other Network Elements, or CLEC's network, and provides appropriate responses. The query originator need not be the owner of LIDB data. LIDB queries include functions such as screening billed numbers that provides the ability to accept Collect or Third Number Billing calls and validation of Telephone Line Number based non-proprietary calling cards. The interface for the LIDB functionality is the interface between the Sprint CCS network and other CCS networks. LIDB also interfaces to administrative systems. The administrative system interface provides Work Centers with an interface to LIDB for functions such as provisioning, auditing of data, access to LIDB measurements and reports.

#### 50.3.2. Technical Requirements

50.3.2.1. Prior to the availability of Local Number Portability, Sprint shall enable CLEC to store in Sprint's LIDB any subscriber Line Number or Special Billing Number record, whether ported or not, for which the NPA-NXX or NXX-0/1XX Group is supported by that LIDB, and NPA-NXX and NXX-0/1XX Group Records, belonging to an NPA-NXX or NXX-0/1XX owned by CLEC.

50.3.2.2. Subsequent to the availability of a long-term solution for Number Portability, Sprint, under the terms of a separate agreement with CLEC, shall enable CLEC to store in Sprint's LIDB any subscriber Line Number or Special Billing Number record, whether ported or not, regardless of the number's NPA-NXX or NXX-0/1XX.

50.3.2.3. Sprint shall perform the following LIDB functions for CLEC's subscriber records in LIDB: Billed Number Screening (provides information such as whether the Billed Number may accept Collect or Third Number Billing calls); and Calling Card Validation.

50.3.2.4. Sprint shall process CLEC's subscriber records in LIDB at Parity with Sprint subscriber records, with respect to other LIDB functions Sprint shall indicate to CLEC what additional functions (if any) are performed by LIDB in their network.

50.3.2.5. Sprint shall perform backup and recovery of all of CLEC's data in LIDB at Parity with backup and recovery of all other records in

the LIDB, including sending to LIDB all changes made since the date of the most recent backup copy.

**50.4. Toll Free Number Database**

50.4.1. The Toll Free Number Database provides functionality necessary for toll free (e.g.: 800 and 888) number services by providing routing information and additional vertical features during call set-up in response to queries from STPs. Sprint, under the terms of a separate agreement with CLEC, shall provide the Toll Free Number Database in accordance with the following:

**50.4.2. Technical Requirements**

50.4.2.1. Sprint shall make the Sprint Toll Free Number Database available for CLEC to query, from CLEC's designated switch including Sprint unbundled local switching with a toll-free number and originating information.

50.4.2.2. The Toll Free Number Database shall return CLEC identification and, where applicable, the queried toll free number, translated numbers and instructions as it would in response to a query from a Sprint switch.

50.4.3. Interface Requirements. The signaling interface between the CLEC or other local switch and the Toll-Free Number database shall use the TCAP protocol, together with the signaling network interface.

**51. OPERATIONS SUPPORT SYSTEMS (OSS).**

51.1. Sprint will offer unbundled access to Sprint's operations support systems. OSS consists of pre-ordering, ordering, provisioning, maintenance and repair, and billing functions supported by Sprint's databases and information. The OSS element includes access to all loop qualification information contained in Sprint's databases or other records, including information on whether a particular loop is capable of providing advanced services.

## **PART F INTERCONNECTION**

### **52. LOCAL INTERCONNECTION TRUNK ARRANGEMENT**

52.1. The Parties agree to initially use two-way trunks (one-way directionalized) for an interim period. The Parties shall transition from directionalized two-way trunks upon mutual agreement, absent engineering or billing issues. The Parties shall transition all one-way trunks established under this Agreement.

52.1.1. The Parties shall initially reciprocally terminate Local Traffic and IntraLATA/InterLATA toll calls originating on the other Party's network as follows:

52.1.1.1. The Parties shall make available to each other two-way trunks for the reciprocal exchange of combined Local Traffic, and non-equal access IntraLATA toll traffic. Neither Party is obligated under this Agreement to order reciprocal trunks or build facilities in the establishment of interconnection arrangements for the delivery of Internet traffic. The Party serving the Internet service provider shall order trunks or facilities from the appropriate tariff of the other Party for such purposes and will be obligated to pay the full cost of such facility.

52.1.1.2. Separate two-way trunks will be made available for the exchange of equal-access InterLATA or IntraLATA interexchange traffic that transits Sprint's network.

52.1.1.3. Separate trunks will be utilized for connecting CLEC's switch to each 911/E911 tandem.

52.2. Point of Interconnection

52.2.1. Point of Interconnection (POI) means the physical point that establishes the technical interface, the test point, and the operational responsibility hand-off between CLEC and Sprint for the local interconnection of their networks. CLEC must establish at least one POI per Sprint local calling area.

52.2.2. CLEC will be responsible for engineering and maintaining its network on its side of the POI. Sprint will be responsible for engineering and maintaining its network on its side of the POI.

52.2.3. For construction of new facilities when the parties choose to interconnect at a mid-span meet, CLEC and Sprint will jointly provision the facilities that connect the two networks. Sprint will be the "controlling carrier" for purposes of MECOD guidelines, as described in the joint implementation plan. Sprint will provide fifty percent (50%) of the facilities or to its

exchange boundary, whichever is less.

52.2.4. Should CLEC prefer, new interconnection facilities may be provisioned via third party facilities or CLEC lease of tariffed services from Sprint. Special construction charges, if applicable, will be charged in accordance with Sprint's access service tariff.

52.2.4.1. If third party leased facilities are used for interconnection, or if leased facilities are provided under a meet-point arrangement between Sprint and a third party, the POI will be defined as the Sprint office in which the leased circuit terminates. CLEC is responsible to terminate the leased facility in a collocation space (if unbundled loops or switched ports will be purchased in the central office) or a set of Sprint-provided DSX jacks to clearly establish the POI.

52.2.4.2. If Sprint-provided-leased facilities are used, the POI will be defined as the demarcation point between Sprint's facility and CLEC's equipment as long as the end point is within Sprint's exchange area.

### **53. INTERCONNECTION COMPENSATION MECHANISMS**

53.1. Each party is responsible for bringing their facilities to POI.

53.2. Interconnection Compensation

53.2.1. If Sprint provides one hundred percent (100%) of the facility, Sprint will charge CLEC one hundred percent (100%) of the lease rates for the facility. CLEC may charge Sprint a proportionate amount of Sprint's dedicated transport rate based on the use of the facility as described above.

53.2.2. If a meet-point is established via construction of new facilities or re-arrangement of existing physical facilities between Sprint and CLEC, the relative use factor will be reduced by the proportionate length of haul provided by each party. Sprint shall be responsible for network provisioning as described in § 52.2.3 herein.

53.2.3. If CLEC provides one-hundred percent (100%) of the interconnection facility via lease of meet-point circuits between Sprint and a third-party; lease of third party facilities; or construction of its own facilities; CLEC may charge Sprint for proportionate amount based on relative usage using the lesser of:

53.2.3.1. Sprint's dedicated interconnection rate;

53.2.3.2. Its own costs if filed and approved by a commission of appropriate jurisdiction; and

- 53.2.3.3. The actual lease cost of the interconnecting facility.
- 53.3. Compensation for Local Traffic Transport and Termination
- 53.3.1. The POI determines the point at which the originating carrier shall pay the terminating carrier for the completion of that traffic. The following compensation elements shall apply:
- 53.3.1.1. "Transport," which includes dedicated and common transport and any necessary Tandem Switching of Local Traffic from the interconnection point between the two carriers to the terminating carrier's end-office switch that directly serves the called end-user; and
- 53.3.1.2. "Termination," which includes the switching of Local Traffic at the terminating carrier's end office switch.
- 53.4. When a CLEC subscriber places a call to Sprint's subscriber, CLEC will hand off that call to Sprint at the POI. Conversely, when Sprint hands off Local Traffic to CLEC for CLEC to transport and terminate, Sprint may use the established POI or Sprint may designate its own POI.
- 53.4.1. CLEC and Sprint may each designate a POI at any technically feasible point including but not limited to any electronic or manual cross-connect points, collocations, entrance facilities, and mid-span meets. The transport and termination charges for Local Traffic flowing through a POI shall be as follows:
- 53.4.1.1. When calls from CLEC are terminating on Sprint's network through the Sprint Tandem Switch, CLEC will pay Sprint for transport charges from the POI to the Tandem for dedicated transport. CLEC shall also pay a charge for Tandem Switching, common transport to the end office, and end-office termination.
- 53.4.1.2. When Sprint terminates calls to CLEC's subscribers using CLEC's switch, Sprint shall pay CLEC for transport charges from the POI to the CLEC switching center for dedicated transport. Sprint shall also pay to CLEC a charge symmetrical to its own charges for the functionality actually provided by CLEC for call termination.
- 53.4.1.3. CLEC may choose to establish direct trunking to any given end office. If CLEC leases trunks from Sprint, it shall pay charges for dedicated transport. For calls terminating from CLEC to subscribers served by these directly-trunked end offices, CLEC shall also pay an end-office termination. For Sprint traffic terminating to CLEC over the direct end office trunking, compensation payable by Sprint shall be the same as that detailed in § 53.4.1.2 above.

## **54. SIGNALING**

- 54.1. Signaling protocol. The parties will interconnect their networks using SS7 signaling where technically feasible and available as defined in FR 905 Telcordia Standards including ISDN user part (ISUP) for trunk signaling and TCAP for CCS-based features in the interconnection of their networks. All Network Operations Forum (NOF) adopted standards shall be adhered to.
- 54.2. Refer to Part E, Article 50 for detailed terms of SS7 Network Interconnection.
- 54.3. Standard interconnection facilities shall be extended superframe (ESF) with B8ZS line code. Where ESF/B8ZS is not available, CLEC will agree to using other interconnection protocols on an interim basis until the standard ESF/B8ZS is available. Sprint will provide anticipated dates of availability for those areas not currently ESF/B8ZS compatible.
  - 54.3.1. Where CLEC is unwilling to utilize an alternate interconnection protocol, CLEC will provide Sprint an initial forecast of 64 Kbps clear channel capability ("64K CCC") trunk quantities within thirty (30) days of the Effective Date consistent with the forecasting agreements between the parties. Upon receipt of this forecast, the parties will begin joint planning for the engineering, procurement, and installation of the segregated 64K CCC Local Interconnection Trunk Groups, and the associated ESF facilities, for the sole purpose of transmitting 64K CCC data calls between CLEC and Sprint. Where additional equipment is required, such equipment would be obtained, engineered, and installed on the same basis and with the same intervals as any similar growth job for IXC, CLEC, or Sprint internal customer demand for 64K CCC trunks.

## **55. NETWORK SERVICING**

- 55.1. Trunk Forecasting
  - 55.1.1. The Parties shall work towards the development of joint forecasting responsibilities for traffic utilization over trunk groups. Orders for trunks that exceed forecasted quantities for forecasted locations will be accommodated as facilities and or equipment are available. The Parties shall make all reasonable efforts and cooperate in good faith to develop alternative solutions to accommodate orders when facilities are not available. Intercompany forecast information must be provided by the Parties to each other twice a year. The initial trunk forecast meeting should take place soon after the first implementation meeting. A forecast should be provided at or prior to the first implementation meeting. The semi-annual forecasts shall project trunk gain/loss on a monthly basis for the forecast period, and shall include:
    - 55.1.1.1. Semi-annual forecasted trunk quantities (which include baseline data that reflect actual Tandem and end office Local

Interconnection and meet point trunks and Tandem-subtending Local Interconnection end office equivalent trunk requirements) for no more than two years (current plus one year);

55.1.1.2. The use of Common Language Location Identifier (CLLI-MSG), which are described in Telcordia documents BR 795-100-100 and BR 795-400-100;

55.1.1.3. Description of major network projects that affect the other Party will be provided in the semi-annual forecasts. Major network projects include but are not limited to trunking or network rearrangements, shifts in anticipated traffic patterns, or other activities by either party that are reflected by a significant increase or decrease in trunking demand for the following forecasting period.

55.1.2. Parties shall meet to review and reconcile their forecasts if forecasts vary significantly.

55.1.3. Each Party shall provide a specified point of contact for planning forecasting and trunk servicing purposes.

55.1.4. Trunking can be established to Tandems or end offices or a combination of both via either one-way or two-way trunks. Trunking will be at the DS-0, DS-1, DS-3/OC-3 level, or higher, as agreed upon by CLEC and Sprint.

55.1.5. The parties agree to abide by the following if a forecast cannot be agreed to: local interconnection trunk groups will be provisioned to the higher forecast. A blocking standard of one percent (1%) during the average busy hour shall be maintained. Should the Parties not agree upon the forecast, and the Parties engineer facilities at the higher forecast, the Parties agree to abide by the following:

55.1.5.1. In the event that one Party over-forecasts its trunking requirements by twenty percent (20%) or more, and the other Party acts upon this forecast to its detriment, the other Party may recoup any actual and reasonable expense it incurs.

55.1.5.2. The calculation of the twenty percent (20%) over-forecast will be based on the number of DS-1 equivalents for the total traffic volume to Sprint.

55.1.5.3. Expenses will only be recouped for non-recoverable facilities that cannot otherwise be used at any time within twelve (12) months after the initial installation for another purpose including but not limited to: other traffic growth between the Parties, internal use, or use with another party.

55.2. Grade of Service. A blocking standard of one percent (1%) during the average



busy hour, as defined by each Party's standards, for final trunk groups between a CLEC end office and a Sprint access Tandem carrying meet point traffic shall be maintained. All other final trunk groups are to be engineered with a blocking standard of one percent (1%). Direct end office trunk groups are to be engineered with a blocking standard of one percent (1%).

- 55.3. Trunk Servicing. Orders between the Parties to establish, add, change or disconnect trunks shall be processed by use of an ASR, or another industry standard eventually adopted to replace the ASR for trunk ordering.

## **56. NETWORK MANAGEMENT**

- 56.1. Protective Protocols. Either Party may use protective network traffic management controls such as 7-digit and 10-digit code gaps on traffic toward each other's network, when required to protect the public switched network from congestion due to facility failures, switch congestion or failure or focused overload. CLEC and Sprint will immediately notify each other of any protective control action planned or executed.
- 56.2. Expansive Protocols. Where the capability exists, originating or terminating traffic reroutes may be implemented by either party to temporarily relieve network congestion due to facility failures or abnormal calling patterns. Reroutes will not be used to circumvent normal trunk servicing. Expansive controls will only be used when mutually agreed to by the parties.
- 56.3. Mass Calling. CLEC and Sprint shall cooperate and share pre-planning information, where available, regarding cross-network call-ins expected to generate large or focused temporary increases in call volumes, to prevent or mitigate the impact of these events on the public switched network. Mass calling numbers are not cannot be used in conjunction with INP.

## **57. USAGE MEASUREMENT**

- 57.1. Each Party shall calculate terminating interconnection minutes of use based on standard AMA recordings made within each Party's network, these recordings being necessary for each Party to generate bills to the other Party. In the event either Party cannot measure minutes terminating on its network where technically feasible, the other Party shall provide the measuring mechanism or the Parties shall otherwise agree on an alternate arrangement.
- 57.2. Measurement of minutes of use over Local Interconnection trunk groups shall be in actual conversation seconds. The total conversation seconds over each individual Local Interconnection trunk group will be totaled for the entire monthly bill period and then rounded to the next whole minute.
- 57.3. Prior to the commencement of billing for interconnection, each Party shall provide to the other, the PLU of the traffic terminated to each other over the Local Interconnection trunk groups.

57.3.1. The Parties agree to review the accuracy of the PLU on a regular basis. If the initial PLU is determined to be inaccurate by more than twenty percent (20%), the Parties agree to implement the new PLU retroactively to the Effective Date of the contract.

## **58. TRANSIT TRAFFIC**

58.1. Transit Traffic means the delivery of local traffic by CLEC or Sprint originated by the end user of one Party and terminated to a third party LEC, ILEC, or CMRS provider over the local/intraLATA interconnection trunks. The following traffic types will be delivered by either Party: local traffic and intraLATA toll and switched traffic originated from CLEC or Sprint and delivered to such third party LEC, ILEC or CMRS; and intraLATA 800 traffic.

### **58.2. Terms and Conditions**

58.2.1. Each Party acknowledges that it is the originating Party's responsibility to enter into arrangements with each third party LEC, ILEC, or CMRS provider for the exchange of transit traffic to that third party, unless the Parties agree otherwise in writing.

58.2.2. Each Party acknowledges that the transiting Party does not have any responsibility to pay any third party LEC, ILEC, or CMRS provider charges for termination or any identifiable transit traffic from the originating Party. Both Parties reserve the right not to pay such charges on behalf of the originating Party.

### **58.3. Payment Terms and Conditions**

58.3.1. In addition to the payment terms and conditions contained in other sections of this Agreement, the Parties shall compensate each other for transit service as follows:

58.3.1.1. The originating Party shall pay to the transiting Party a transit service charge as set forth in the Pricing Schedule; and

58.3.1.2. If the terminating Party requests, and the transiting Party does not provide, the terminating Party with the originating record in order for the terminating Party to bill the originating Party, the terminating Party shall default bill the transiting Party for transited traffic which does not identify the originating Party.

### **58.4. Billing Records and Exchange of Data**

58.4.1. Parties will use the best efforts to convert all networks transporting transit traffic to deliver each call to the other Party's network with SS7 Common Channel Interoffice Signaling (CCIS) and other appropriate TCAP messages in order to facilitate full interoperability and billing functions. The Parties agree to send all message indicators, including originating

telephone number, local routing number and CIC.

58.4.2. The transiting Party agrees to provide the terminating Party information on traffic originated by a third party CLEC, ILEC, or CMRS provider. To the extent Sprint incurs additional cost in providing this billing information, CLEC agrees to reimburse Sprint for its direct costs of providing this information.

58.4.3. To the extent that the industry adopts a standard record format for recording originating and/or terminating transit calls, both Parties agree to comply with the industry-adopted format to exchange records.

## **59. RESPONSIBILITIES OF THE PARTIES**

59.1. Sprint and CLEC will review engineering requirements consistent with the Implementation Plan described in Part B, Article 32 and Part C, Part F, Article 55 and otherwise as set forth in this Agreement.

59.2. CLEC and Sprint shall share responsibility for all Control Office functions for Local Interconnection Trunks and Trunk Groups, and both parties shall share the overall coordination, installation, and maintenance responsibilities for these trunks and trunk groups.

59.3. CLEC and Sprint shall:

59.3.1. Provide trained personnel with adequate and compatible test equipment to work with each other's technicians.

59.3.2. Notify each other when there is any change affecting the service requested, including the due date.

59.3.3. Coordinate and schedule testing activities of their own personnel, and others as applicable, to ensure its interconnection trunks/trunk groups are installed per the interconnection order, meet agreed-upon acceptance test requirements, and are placed in service by the due date.

59.3.4. Perform sectionalization to determine if a trouble is located in its facility or its portion of the interconnection trunks prior to referring the trouble to each other.

59.3.5. Advise each other's Control Office if there is an equipment failure which may affect the interconnection trunks.

59.3.6. Provide each other with a trouble reporting/repair contact number that is readily accessible and available twenty-four (24) hours/seven (7) days a week. Any changes to this contact arrangement must be immediately provided to the other party.

59.3.7. Provide to each other test-line numbers and access to test lines.

59.3.8. Cooperatively plan and implement coordinated repair procedures for the meet point and Local Interconnection trunks and facilities to ensure trouble reports are resolved in a timely and appropriate manner.

## **PART G INTERIM NUMBER PORTABILITY**

### **60. SPRINT PROVISION OF INTERIM NUMBER PORTABILITY**

60.1. Sprint shall provide INP in accordance with requirements of the Act and FCC Rules and Regulations. INP shall be provided with minimum impairment of functionality, quality, reliability and convenience to subscribers of CLEC services until such time as LNP service is offered in the Sprint rate center, in which case INP will be discontinued. Beginning on the date LNP is available in an area, INP orders will no longer be processed, and the Parties will work together to convert the existing INP lines to LNP.

### **61. INTERIM NUMBER PORTABILITY**

- 61.1. Interim Number Portability (INP) shall be provided to the extent technical capabilities allow, by a Sprint directed Remote Call Forwarding (RCF). In the event RCF is a purchased feature of the CLEC end user, there is no relationship between RCF and INP. Once LNP is generally available in Sprint's serving area, RCF will be provided only as a retail service offering by Sprint.
- 61.2. Remote Call Forwarding (RCF) is an INP method to provide subscribers with service-provider portability by redirecting calls within the telephone network. When RCF is used to provide interim number portability, calls to the ported number will first route to the Sprint switch to which the ported number was previously assigned. The Sprint switch will then forward the call to a number associated with the CLEC designated switch to which the number is ported. CLEC may order any additional paths to handle multiple simultaneous calls to the same ported telephone number.
- 61.3. The trunking requirements will be agreed upon by Sprint and CLEC resultant from application of sound engineering principles. These trunking options may include SS7 signaling, in-band signaling, and may be one-way or two-way. The trunks used may be the same as those used for exchange of other Local Traffic and toll traffic between Sprint and CLEC.
- 61.4. Local Exchange Routing Guide (LERG) Reassignment. Portability for an entire NXX shall be provided by utilizing reassignment of the block to CLEC through the LERG. Updates to translations in the Sprint switching office from which the telephone number is ported will be made by Sprint prior to the date on which LERG changes become effective, in order to redirect calls to the CLEC switch via route indexing.
- 61.5. Other Currently Available Number Portability Provisions:
- 61.5.1. Where SS7 is available, Sprint shall exchange with CLEC, SS7 TCAP messages as required for the implementation CLASS or other features available in the Sprint network, if technically feasible.

- 61.5.2. Upon notification that CLEC will be initiating INP, Sprint shall disclose to CLEC any technical or capacity limitations that would prevent use of the requested INP in the affected switching office. Sprint and CLEC shall cooperate in the process of porting numbers to minimize subscriber out-of-service time, including promptly updating switch translations, where necessary, after notification that physical cut-over has been completed (or initiated), as CLEC may designate.
- 61.5.3. For INP, CLEC shall have the right to use the existing Sprint 911 infrastructure for all 911 capabilities. When RCF is used for CLEC subscribers, both the ported numbers and shadow numbers shall be stored in ALI databases. CLEC shall have the right to verify the accuracy of the information in the ALI databases.
- 61.5.3.1. When any INP method is used to port a subscriber, the donor provider must maintain the LIDB record for that number to reflect appropriate conditions as reported to it by the porting service provider. The donor must outclear call records to CLEC for billing and collection from the subscriber. Until such time as Sprint's LIDB has the software capability to recognize a ported number as CLEC's, Sprint shall store the ported number in its LIDB at no charge and shall retain revenue for LIDB look-ups to the ported number. At such time as Sprint's LIDB has the software capability to recognize that the ported number is CLEC's then, if CLEC desires to store numbers on Sprint's LIDB, the parties shall negotiate a separate LIDB database storage and look-up agreement.
- 61.5.4. Sprint will send a CARE transaction 2231 to notify IXC that access is now provided by a new CLEC for that number.

## **62. REQUIREMENTS FOR INP**

### **62.1. Cut-Over Process**

- 62.1.1. Sprint and CLEC shall cooperate in the process of porting numbers from one carrier to another so as to limit service outage for the ported subscriber.
- 62.1.1.1. For a Coordinated Cutover Environment, Sprint and CLEC will coordinate the disconnect and switch translations as close to the requested time as possible. The coordination shall be pre-specified by CLEC and agreed to by both parties and in no case shall begin more than thirty (30) minutes after the agreed upon time.
- 62.1.1.2. For a Non-Coordinated Cutover Environment, the Parties will agree to a mutually satisfactory cutover time and Sprint shall schedule an update of disconnect and switch translations at the agreed upon cutover time. Such updates will be available to CLEC

at Parity with Sprint's own availability for such activity. Sprint and CLEC shall each provide an appropriate operations contact with whom the Parties can contact in the event manual intervention is needed to complete the cutover. In the event of manual intervention, and if Sprint is unable to resolve the issue within sixty (60) minutes, Sprint shall notify CLEC of the issue and CLEC and Sprint shall determine the plan to resolve it.

62.2. **Testing.** Sprint and CLEC shall cooperate in conducting CLEC's testing to ensure interconnectivity between systems. Sprint shall inform CLEC of any system updates that may affect the CLEC network and Sprint shall, at CLEC's request, perform tests to validate the operation of the network. Additional testing requirements may apply as specified by this Agreement.

62.3. **Installation Timeframes**

62.3.1. **Installation Time Frames for RCF INP,** where no other work is required, will be completed using Sprint's standard interval for service installation of complex services.

62.3.2. If a subscriber elects to move its Telephone Exchange Service back to Sprint while on an INP arrangement, Sprint shall notify CLEC of the Subscriber's termination of service with CLEC and the Subscriber's instructions regarding its telephone number(s) at Parity with what is offered to other Sprint customers.

62.4. **Call Referral Announcements.** Should CLEC direct Sprint to terminate INP measures, Sprint shall allow CLEC to order a referral announcement available in that switch.

62.5. **Engineering and Maintenance.** Sprint and CLEC will cooperate to ensure that performance of trunking and signaling capacity is engineered and managed at levels which are at Parity with that provided by Sprint to its subscribers and to ensure effective maintenance testing through activities such as routine testing practices, network trouble isolation processes and review of operational elements for translations, routing and network fault isolation.

62.6. **Operator Services and Directory Assistance**

62.6.1. With respect to operator services and directory assistance associated with INP for CLEC subscribers, Sprint shall provide the following:

62.6.1.1. While INP is deployed:

62.6.1.1.1. Sprint shall allow CLEC to order provisioning of Telephone Line Number (TLN) calling cards and Billed Number Screening (BNS), in its LIDB, for ported numbers, as specified by CLEC. Sprint shall continue to allow

CLEC access to its LIDB. Other LIDB provisions are specified in this Agreement.

62.6.1.1.2. Where Sprint has control of directory listings for NXX codes containing ported numbers, Sprint shall maintain entries for ported numbers as specified by CLEC.

62.6.2. Sprint OSS shall meet all requirements specified in "Generic Operator Services Switching Requirements for Number Portability," Issue 1.00, Final Draft, April 12, 1996. Editor - Nortel.

62.7. Number Reservation. When a subscriber ports to another service provider and has previously secured, via a tariffed offering, a reservation of line numbers from the donor provider for possible activation at some future point, these reserved but inactive numbers shall "port" along with the active numbers being ported by the subscriber in order to ensure that the end user subscriber will be permitted to expand its service using the same number range it could use if it remained with the donor provider. However, Sprint will not port vacant numbers.



## **PART H LOCAL NUMBER PORTABILITY**

### **63. INTRODUCTION**

- 63.1. Upon implementation of LNP, both Parties agree to conform and provide such LNP pursuant to FCC regulations and compliance with the Industry Forum. To the extent consistent with the FCC and Industry rules as amended from time to time, the requirements for LNP shall include the following:
- 63.1.1. Subscribers must be able to change local service providers and retain the same telephone number(s) within the serving wire center utilizing the portability method in effect within the porting MSA, as offered by the porting carrier, and within the area of portability as defined by the FCC or state commission having jurisdiction over this Agreement.
  - 63.1.2. The LNP network architecture shall not subject Parties to any degradation of service in any relevant measure, including transmission quality, switching and transport costs, increased call set-up time and post-dial delay.
  - 63.1.3. Parties agree that when an NXX is defined as portable, it shall also be defined as portable in all LNP capable offices which have direct trunks to the given switch.
  - 63.1.4. When a subscriber ports to another service provider and has previously secured a reservation of line numbers from the donor provider for possible activation at some future point, these reserved but inactive numbers shall port along with the active numbers being ported by the subscriber only in states where appropriate charges from Sprint tariffs are executed for reserved numbers.
  - 63.1.5. NXX Availability. Not all NXXs in each CO may be available for porting.
  - 63.1.6. LERG Reassignment. Portability for an entire NXX shall be provided by utilizing reassignment of the NXX to CLEC through the LERG.
  - 63.1.7. Coordination of service order work outside normal business hours (8:00AM to 5:00PM) shall be at requesting Party's expense. Premium rates will apply for service order work performed outside normal business hours, weekends, and holidays.
  - 63.1.8. Mass Calling Events. Parties will notify each other at least seven (7) days in advance where ported numbers are utilized. Parties will only port mass calling numbers using switch translations and a choke network for call routing. Porting on mass calling numbers will be handled outside the normal porting process and comply with any applicable state or federal regulatory requirements developed for mass calling numbers.

### **64. TRANSITION FROM INP TO LNP**

- 64.1. Existing INP Arrangements. As Sprint provisions LNP according to the industry schedule in a Wire Center/Central Office, there will be a maximum of a ninety (90) day transition from INP to LNP. At that time, the CLEC will be required to fully implement LNP according to industry standards.
- 64.2. Once LNP is available in an area, all new portability will be LNP and INP will no longer be offered.

## **65. TESTING**

- 65.1. An Interconnection Agreement (or Memorandum of Understanding, or Porting Agreement) detailing conditions for LNP must be in effect between the Parties prior to testing.
- 65.2. Testing and operational issues will be addressed in the implementation plans as described in Part B, §32 of the agreement.
- 65.3. CLEC must be NPAC certified and have met Sprint testing parameters prior to activating LNP. If LNP implementation by a CLEC/CMRS provider occurs past the FCC activation date, testing and porting will be done at CLEC's expense.
- 65.4. Parties will cooperate to ensure effective maintenance testing through activities such as routine testing practices, network trouble isolation processes and review of operational elements for translations, routing and network fault isolation.
- 65.5. Parties shall cooperate in testing performed to ensure interconnectivity between systems. All LNP providers shall notify each connected provider of any system updates that may affect the CLEC or Sprint network. Each LNP provider shall, at each other's request, jointly perform tests to validate the operation of the network. Additional testing requirements may apply as specified by this Agreement or in the Implementation Plan.

## **66. ENGINEERING AND MAINTENANCE**

- 66.1. Each LNP provider will monitor and perform effective maintenance through testing and the performance of proactive maintenance activities such as routine testing, development of and adherence to appropriate network trouble isolation processes and periodic review of operational elements for translations, routing and network faults.
- 66.2. It will be the responsibility of the Parties to ensure that the network is stable and maintenance and performance levels are maintained in accordance with state commission requirements. It will be the responsibility of the Parties to perform fault isolation in their network before involving other providers.
- 66.3. Additional engineering and maintenance requirements shall apply as specified in this Agreement or the Implementation Plan.

**67. E911/911**

- 67.1. When a subscriber ports to another service provider, the donor provider shall use information provided by the porting provider to update the 911 tandem switch routing tables and 911/ALI database to correctly route, and provide accurate information to PSAP call centers.
- 67.2. Prior to implementation of LNP, the Parties agree to develop, implement, and maintain efficient methods to maintain 911 database integrity when a subscriber ports to another service provider. The Parties agree that the customer shall not be dropped from the 911 database during the transition.

**68. BILLING**

- 68.1. When an IXC terminates an InterLATA or IntraLATA toll call to either party's local exchange customer whose telephone number has been ported from one party to the other, the parties agree that the party to whom the number has been ported shall receive revenues from those IXC access charges associated with end office switching, local transport, RIC, and CCL, as appropriate, and such other applicable charges. The party from whom the number has been ported shall be entitled only to receive any entrance facility fees, access tandem fees and appropriate local transport charges as set forth in this Agreement. Such access charge payments will be adjusted to the extent that the paying party has already paid Reciprocal Compensation for the same minutes of use. When a call for which access charges are not applicable is terminated to a party's local exchange customer whose telephone number has been ported from the other party, the parties agree that the Reciprocal compensation arrangements described in this Agreement shall apply.
- 68.2. Non-Payment. Customers lose the right to the ported telephone number upon non-payment of charges. Sprint will not port telephone numbers of customers who have bills in default.

## **PART I GENERAL BUSINESS REQUIREMENTS**

### **69. PROCEDURES**

#### **69.1. Contact with Subscribers**

69.1.1. Each Party at all times shall be the primary contact and account control for all interactions with its subscribers, except as specified by that Party. Subscribers include active subscribers as well as those for whom service orders are pending.

69.1.2. Each Party shall ensure that any of its personnel who may receive subscriber inquiries, or otherwise have opportunity for subscriber contact from the other Party's subscribers regarding the other Party's services: (i) provide appropriate referrals to subscribers who inquire about the other Party's services or products; (ii) do not in any way disparage or discriminate against the other Party, or its products or services; and (iii) do not provide information about its products or services during that same inquiry or subscriber contact.

69.1.3. Sprint shall not use CLEC's request for subscriber information, order submission, or any other aspect of CLEC's processes or services to aid Sprint's marketing or sales efforts.

#### **69.2. Expedite and Escalation Procedures**

69.2.1. Sprint and CLEC shall develop mutually acceptable escalation and expedite procedures which may be invoked at any point in the Service Ordering, Provisioning, Maintenance, and Subscriber Usage Data transfer processes to facilitate rapid and timely resolution of disputes. In addition, Sprint and CLEC will establish intercompany contacts lists for purposes of handling subscriber and other matters which require attention/resolution outside of normal business procedures within thirty (30) days after CLEC's request. Each party shall notify the other party of any changes to its escalation contact list as soon as practicable before such changes are effective.

69.2.2. No later than thirty (30) days after CLEC's request Sprint shall provide CLEC with contingency plans for those cases in which normal Service Ordering, Provisioning, Maintenance, Billing, and other procedures for Sprint's unbundled Network Elements, features, functions, and resale services are inoperable.

69.3. **Subscriber of Record.** Sprint shall recognize CLEC as the Subscriber of Record for all Network Elements or services for resale ordered by CLEC and shall send all notices, invoices, and information which pertain to such ordered services directly to CLEC. CLEC will provide Sprint with addresses to which Sprint shall send all such notices, invoices, and information.

#### 69.4. Service Offerings

- 69.4.1. Sprint shall provide CLEC with access to new services, features and functions concurrent with Sprint's notice to CLEC of such changes, if such service, feature or function is installed and available in the network or as soon thereafter as it is installed and available in the network, so that CLEC may conduct market testing.
- 69.4.2. Essential Services. For purposes of service restoral, Sprint shall designate a CLEC access line as an Essential Service Line (ESL) at Parity with Sprint's treatment of its own subscribers and applicable state law or regulation, if any.
- 69.4.3. Blocking Services. Upon request from CLEC, employing Sprint-approved LSR documentation, Sprint shall provide blocking of 700, 900, and 976 services, or other services of similar type as may now exist or be developed in the future, and shall provide Billed Number Screening (BNS), including required LIDB updates, or equivalent service for blocking completion of bill-to-third party and collect calls, on a line, PBX, or individual service basis. Blocking shall be provided the extent (a) it is an available option for the Telecommunications Service resold by CLEC, or (b) it is technically feasible when requested by CLEC as a function of unbundled Network Elements.
- 69.4.4. Training Support. Sprint shall provide training, on a non-discriminatory basis, for all Sprint employees who may communicate, either by telephone or face-to-face, with CLEC subscribers. Such training shall include compliance with the branding requirements of this Agreement including without limitation provisions of forms, and unbranded "Not at Home" notices.

#### 70. ORDERING AND PROVISIONING

- 70.1. Ordering and Provisioning Parity. Sprint shall provide necessary ordering and provisioning business process support as well as those technical and systems interfaces as may be required to enable CLEC to provide the same level and quality of service for all resale services, functions, features, capabilities and unbundled Network Elements at Parity.
- 70.2. National Exchange Access Center (NEAC)
- 70.2.1. Sprint shall provide a NEAC or equivalent which shall serve as CLEC's point of contact for all activities involved in the ordering and provisioning of Sprint's unbundled Network Elements, features, functions, and resale services.
- 70.2.2. The NEAC shall provide to CLEC a nationwide telephone number (available from 6:00 a.m. to 8:00 p.m. Eastern Standard Time, Monday

through Friday, and 8:00 am through 5:00 P.M. Eastern Standard Time on Saturday) answered by competent, knowledgeable personnel and trained to answer questions and resolve problems in connection with the ordering and provisioning of unbundled Network Elements (except those associated with local trunking interconnection), features, functions, capabilities, and resale services.

70.2.3. Sprint shall provide, as requested by CLEC, through the NEAC, provisioning and premises visit installation support in the form of coordinated scheduling, status, and dispatch capabilities during Sprint's standard business hours and at other times as agreed upon by the parties to meet subscriber demand.

70.3. Street Index Guide (SIG). Within thirty (30) days of CLEC's written request, Sprint shall provide to CLEC the SAG data, or its equivalent, in an electronic format mutually agreeable to the parties. All changes and updates to the SAG shall be provided to in a mutually agreed format and timeframe.

70.4. CLASS and Custom Features. Where generally available in Sprint's serving area, CLEC, at the tariff rate, may order the entire set of CLASS, CENTREX and Custom features and functions, or a subset of any one of such features.

70.5. Number Administration/Number Reservation

70.5.1. Sprint shall provide testing and loading of CLEC's NXX on the same basis as Sprint provides itself or its affiliates. Further, Sprint shall provide CLEC with access to abbreviated dialing codes, and the ability to obtain telephone numbers, including vanity numbers, while a subscriber is on the phone with CLEC. When CLEC uses numbers from a Sprint NXX, Sprint shall provide the same range of number choices to CLEC, including choice of exchange number, as Sprint provides its own subscribers. Reservation and aging of Sprint NXX's shall remain Sprint's responsibility.

70.5.2. In conjunction with an order for service, Sprint shall accept CLEC orders for vanity numbers and blocks of numbers for use with complex services including, but not limited to, DID, CENTREX, and Hunting arrangements, as requested by CLEC.

70.5.3. For simple services number reservations and aging of Sprint's numbers, Sprint shall provide real-time confirmation of the number reservation when the Electronic Interface has been implemented. For number reservations associated with complex services, Sprint shall provide confirmation of the number reservation within twenty-four (24) hours of CLEC's request. Consistent with the manner in which Sprint provides numbers to its own subscribers, no telephone number assignment is guaranteed until service has been installed.

70.6. Service Order Process Requirements

## 70.6.1. Service Migrations and New Subscriber Additions

70.6.1.1. For resale services, other than for a CLEC order to convert “as is” a CLEC subscriber, Sprint shall not disconnect any subscriber service or existing features at any time during the migration of that subscriber to CLEC service without prior CLEC agreement.

70.6.1.2. For services provided through UNEs, Sprint shall recognize CLEC as an agent, in accordance with OBF developed processes, for the subscriber in coordinating the disconnection of services provided by another CLEC or Sprint. In addition, Sprint and CLEC will work cooperatively to minimize service interruptions during the conversion.

70.6.1.3. Unless otherwise directed by CLEC and when technically capable, when CLEC orders resale Telecommunications Services or UNEs all trunk or telephone numbers currently associated with existing services shall be retained without loss of feature capability and without loss of associated ancillary services including, but not limited to, Directory Assistance and 911/E911 capability.

70.6.1.4. For subscriber conversions requiring coordinated cut-over activities, on a per order basis, Sprint, to the extent resources are readily available, and CLEC will agree on a scheduled conversion time, which will be a designated time period within a designated date.

70.6.1.4.1. Any request made by CLEC to coordinate conversions after normal working hours, or on Saturday’s or Sunday’s or Sprint holidays shall be performed at CLEC’s expense.

70.6.1.5. A general Letter of Agency (LOA) initiated by CLEC or Sprint will be required to process a PLC or PIC change order. Providing the LOA, or a copy of the LOA, signed by the end user will not be required to process a PLC or PIC change ordered by CLEC or Sprint. CLEC and Sprint agree that PLC and PIC change orders will be supported with appropriate documentation and verification as required by FCC and Commission rules. In the event of a subscriber complaint of an unauthorized PLC record change where the Party that ordered such change is unable to produce appropriate documentation and verification as required by FCC and Commission rules (or, if there are no rules applicable to PLC record changes, then such rules as are applicable to changes in long distance carriers of record), such Party shall be liable to pay and shall pay all nonrecurring and/or other charges associated with reestablishing the subscriber’s local service with the original local

carrier.

70.6.2. **Intercept Treatment and Transfer Service Announcements.** Sprint shall provide unbranded intercept treatment and transfer of service announcements to CLEC's subscribers. Sprint shall provide such treatment and transfer of service announcement in accordance with local tariffs and as provided to similarly situated Sprint subscribers for all service disconnects, suspensions, or transfers.

70.6.3. **Due Date**

70.6.3.1. Sprint shall supply CLEC with due date intervals to be used by CLEC personnel to determine service installation dates.

70.6.3.2. Sprint shall use best efforts to complete orders by the CLEC requested DDD within agreed upon intervals.

70.6.4. **Subscriber Premises Inspections and Installations**

70.6.4.1. CLEC shall perform or contract for all CLEC's needs assessments, including equipment and installation requirements required beyond the Demarcation/NID, located at the subscriber premises.

70.6.4.2. Sprint shall provide CLEC with the ability to schedule subscriber premises installations at the same morning and evening commitment level of service offered Sprint's own customers. The parties shall mutually agree on an interim process to provide this functionality during the implementation planning process.

70.6.5. **Firm Order Confirmation (FOC)**

70.6.5.1. Sprint shall provide to CLEC, a Firm Order Confirmation (FOC) for each CLEC order. The FOC shall contain the appropriate data elements as defined by the OBF standards.

70.6.5.2. For a revised FOC, Sprint shall provide standard detail as defined by the OBF standards.

70.6.5.3. Sprint shall provide to CLEC the date that service is scheduled to be installed.

70.6.6. **Order Rejections**

70.6.6.1. Sprint shall reject and return to CLEC any order that Sprint cannot provision, due to technical reasons, missing information, or jeopardy conditions resulting from CLEC ordering service at less than the standard order interval. When an order is rejected, Sprint shall, in its reject notification, specifically describe all of the reasons for which the order was rejected. Sprint shall reject any



orders on account of the customer Desired Due Date conflicts with published Sprint order provisioning interval requirements.

#### 70.6.7. Service Order Changes

70.6.7.1. In no event will Sprint change a CLEC initiated service order without a new service order directing said change. If an installation or other CLEC ordered work requires a change from the original CLEC service order in any manner, CLEC shall initiate a revised service order. If requested by CLEC, Sprint shall then provide CLEC an estimate of additional labor hours and/or materials.

70.6.7.1.1. When a service order is completed, the cost of the work performed will be reported promptly to CLEC.

70.6.7.2. If a CLEC subscriber requests a service change at the time of installation or other work being performed by Sprint on behalf of CLEC, Sprint, while at the subscriber premises, shall direct the CLEC subscriber to contact CLEC, and CLEC will initiate a new service order.

70.7. Network Testing. Sprint shall perform all its standard pre-service testing prior to the completion of the service order.

70.8. Service Suspensions/Restorations. Upon CLEC's request through an Industry Standard, OBF, Suspend/Restore Order, or mutually agreed upon interim procedure, Sprint shall suspend or restore the functionality of any Network Element, feature, function, or resale service to which suspend/restore is applicable. Sprint shall provide restoration priority on a per network element basis in a manner that conforms with any applicable regulatory Rules and Regulations or government requirements.

70.9. Order Completion Notification. Upon completion of the requests submitted by CLEC, Sprint shall provide to CLEC a completion notification in an industry standard, OBF, or in a mutually agreed format. The completion notification shall include detail of the work performed, to the extent this is defined within OBF guidelines, and in an interim method until such standards are defined.

70.10. Specific Unbundling Requirements. CLEC may order and Sprint shall provision unbundled Network Elements. However, it is CLEC's responsibility to combine the individual network elements should it desire to do so.

#### 70.11. Systems Interfaces and Information Exchanges

##### 70.11.1. General Requirements

70.11.1.1. Sprint shall provide to CLEC Electronic Interface(s) for transferring and receiving information and executing transactions

for all business functions directly or indirectly related to Service Ordering and Provisioning of Network Elements, features, functions and Telecommunications Services. The Interface(s) shall be developed/designed for the transmission of data from CLEC to Sprint, and from Sprint to CLEC.

70.11.1.2. Interim interfaces or processes may be modified, if so agreed by CLEC and Sprint, during the interim period.

70.11.1.3. Until the Electronic Interface is available, Sprint agrees that the NEAC or similar function will accept CLEC orders. Orders will be transmitted to the NEAC via an interface or method agreed upon by CLEC and Sprint.

70.11.2. For any CLEC subscriber Sprint shall provide, subject to applicable rules, orders, and decisions, CLEC with access CPNI without requiring CLEC to produce a signed LOA, based on CLEC's blanket representation that subscriber has authorized CLEC to obtain such CPNI.

70.11.2.1. The preordering Electronic Interface includes the provisioning of CPNI from Sprint to CLEC. The Parties agree to execute a LOA agreement with the Sprint end user prior to requesting CPNI for that Sprint end user, and to request end user CPNI only when the end user has specifically given permission to receive CPNI. The Parties agree that they will conform to FCC and/or state regulations regarding the provisioning of CPNI between the parties, and regarding the use of that information by the requesting party.

70.11.2.2. The requesting Party will document end user permission obtained to receive CPNI, whether or not the end user has agreed to change local service providers. For end users changing service from one party to the other, specific end user LOAs may be requested by the Party receiving CPNI requests to investigate possible slamming incidents, and for other reasons agreed to by the Parties.

70.11.2.3. The receiving Party may also request documentation of an LOA if CPNI is requested and a subsequent service order for the change of local service is not received. On a schedule to be determined by Sprint, Sprint will perform a comparison of requests for CPNI to service orders received for the change of Local Service to CLEC. Sprint will produce a report of unmatched requests for CPNI, and may require an LOA from CLEC for each unmatched request. CLEC agrees to provide evidence of end user permission for receipt of CPNI for all end users in the request by Sprint within three (3) business days of receipt of a request from Sprint. Should

Sprint determine that there has been a substantial percentage of unmatched LOA requests, Sprint reserves the right to immediately disconnect the preordering Electronic Interface.

- 70.11.2.4. If CLEC is not able to provide the LOA for ninety-five percent (95%) of the end users requested by Sprint, or if Sprint determines that an LOA is inadequate, CLEC will be considered in breach of the agreement. CLEC can cure the breach by submitting to Sprint evidence of an LOA for each inadequate or omitted LOA within three (3) business days of notification of the breach.
- 70.11.2.5. Should CLEC not be able to cure the breach in the timeframe noted above, Sprint will discontinue processing new service orders until, in Sprint's determination, CLEC has corrected the problem that caused the breach.
- 70.11.2.6. Sprint will resume processing new service orders upon Sprint's timely review and acceptance of evidence provided by CLEC to correct the problem that caused the breach.
- 70.11.2.7. If CLEC and Sprint do not agree that CLEC requested CPNI for a specific end user, or that Sprint has erred in not accepting proof of an LOA, the Parties may immediately request dispute resolution in accordance with Part B. Sprint will not disconnect the preordering Electronic Interface during the Alternate Dispute Resolution process.
- 70.11.2.8. When available per Electronic Interface Implementation Plan, Sprint shall provide to CLEC Electronic Interface to Sprint information systems to allow CLEC to assign telephone number(s) (if the subscriber does not already have a telephone number or requests a change of telephone number) at Parity.
- 70.11.2.9. When available per Electronic Interface Implementation Plan, Sprint shall provide to CLEC an Electronic Interface to schedule dispatch and installation appointments at Parity.
- 70.11.2.10. When available per Electronic Interface Implementation Plan, Sprint shall provide to CLEC an Electronic Interface to Sprint subscriber information systems which will allow CLEC to determine if a service call is needed to install the line or service at Parity.
- 70.11.2.11. When available per Electronic Interface Implementation Plan, Sprint shall provide to CLEC an Electronic Interface to Sprint information systems which will allow CLEC to provide service availability dates at Parity.
- 70.11.2.12. When available per Electronic Interface Implementation Plan,

Sprint shall provide to CLEC an Electronic Interface which transmits status information on service orders at Parity. Until an Electronic Interface is available, Sprint agrees that Sprint will provide proactive status on service orders at the following critical intervals: acknowledgment, firm order confirmation, and completion according to interim procedures to be mutually developed.

70.12. Standards

70.12.1. General Requirements. CLEC and Sprint shall agree upon the appropriate ordering and provisioning codes to be used for UNEs. These codes shall apply to all aspects of the unbundling of that element and shall be known as data elements as defined by the Telecommunications Industry Forum Electronic Data Interchange Service Order Subcommittee (TCIF-EDI-SOSC).

**71. BILLING**

- 71.1. Sprint shall comply with various industry, OBF, and other standards referred to throughout this Agreement. Sprint will review any changes to industry standards, and implement the changes within the industry-defined window. Sprint will notify CLEC of any deviations to the standards.
- 71.2. Sprint shall bill CLEC for each service supplied by Sprint to CLEC pursuant to this Agreement at the rates set forth in this Agreement.
- 71.3. Sprint shall provide to CLEC a single point of contact for interconnection at the National Access Service Center (NASC), and Network Elements and resale at Sprint's NEAC, to handle any Connectivity Billing questions or problems that may arise during the implementation and performance of the terms and conditions of this Agreement.
- 71.4. Sprint shall provide a single point of contact for handling of any data exchange questions or problems that may arise during the implementation and performance of the terms and conditions of this Agreement.
- 71.5. Subject to the terms of this Agreement, CLEC shall pay Sprint within thirty (30) days from the Bill Date. If the payment due date is a Saturday, Sunday or has been designated a bank holiday payment shall be made the next business day.
- 71.6. Billed amounts for which written, itemized disputes or claims have been filed shall be handled in accordance with the procedures set forth in Part B, Article 23 of this Agreement.
- 71.7. Sprint will assess late payment charges to CLEC in accordance with Part B, §6.5 of this Agreement.
- 71.8. Sprint shall credit CLEC for incorrect Connectivity Billing charges including

without limitation: overcharges, services ordered or requested but not delivered, interrupted services, services of poor quality and installation problems if caused by Sprint. Such reimbursements shall be set forth in the appropriate section of the Connectivity Bill pursuant to CABS, or SECAB standards.

- 71.9. Where Parties have established interconnection, Sprint and the CLEC agree to conform to MECAB and MECOD guidelines. They will exchange Billing Account Reference and Bill Account Cross Reference information and will coordinate Initial Billing Company/Subsequent Billing Company billing cycles. Sprint and CLEC will exchange the appropriate records to bill exchange access charges to the IXC. Sprint and CLEC agree to capture EMI records for inward terminating and outward originating calls and send them to the other, as appropriate, in daily or other agreed upon interval, via and agreed upon media (e.g.: Connect Direct, cartridge or magnetic tape).
- 71.10. Revenue Protection. Sprint shall make available to CLEC, at Parity with what Sprint provides to itself, its Affiliates and other local telecommunications CLECs, all present and future fraud prevention or revenue protection features, including prevention, detection, or control functionality embedded within any of the Network Elements. These features include, but are not limited to screening codes, information digits assigned such as information digits '29' and '70' which indicate prison and COCOT pay phone originating line types respectively, call blocking of domestic, international, 800, 888, 900, NPA-976, 700, 500 and specific line numbers, and the capability to require end-user entry of an authorization code for dial tone. Sprint shall, when technically capable and consistent with the implementation schedule for Operations Support Systems (OSS), additionally provide partitioned access to fraud prevention, detection and control functionality within pertinent OSS.

## **72. PROVISION OF SUBSCRIBER USAGE DATA**

- 72.1. This Article 72 sets forth the terms and conditions for Sprint's provision of Recorded Usage Data (as defined in this Part) to CLEC and for information exchange regarding long distance billing. The parties agree to record call information for interconnection in accordance with this Article 4. To the extent technically feasible, each party shall record all call detail information associated with completed calls originated by or terminated to the other Party's local exchange subscriber. Sprint shall record for CLEC the messages that Sprint records for and bills to its end users. These records shall be provided at a party's request and shall be formatted pursuant to Telcordia's EMI standards and the terms and conditions of this Agreement. These records shall be transmitted to the other party on non-holiday business days in EMI format via CDN, or provided on a cartridge or magnetic tape. Sprint and CLEC agree that they shall retain, at each party's sole expense, copies of all EMI records transmitted to the other party for at least forty-five (45) calendar days after transmission to the other party.

- 72.2. General Procedures

- 72.2.1. Sprint shall comply with various industry and OBF standards referred to throughout this Agreement.
- 72.2.2. Sprint shall comply with OBF standards when recording and transmitting Usage Data.
- 72.2.3. Sprint shall record all usage originating from CLEC subscribers using resold services ordered by CLEC, where Sprint records those same services for Sprint subscribers. Recorded Usage Data includes, but is not limited to, the following categories of information:
  - 72.2.3.1. Use of CLASS/LASS/Custom Features that Sprint records and bills for its subscribers on a per usage basis.
  - 72.2.3.2. Calls to Information Providers (IP) reached via Sprint facilities will be provided in accordance with §72.2.7
  - 72.2.3.3. Calls to Directory Assistance where Sprint provides such service to a CLEC subscriber.
  - 72.2.3.4. Calls completed via Sprint-provided Operator Services where Sprint provides such service to CLEC's local service subscriber and where Sprint records such usage for its subscribers using Industry Standard Telcordia EMI billing records.
  - 72.2.3.5. For Sprint-provided Centrex Service, station level detail.
- 72.2.4. Retention of Records. Sprint shall maintain a machine readable back-up copy of the message detail provided to CLEC for a minimum of forty-five (45) calendar days. During the forty-five (45) day period, Sprint shall provide any data back-up to CLEC upon the request of CLEC. If the forty-five (45) day has expired, Sprint may provide the data back-up at CLEC's expense.
- 72.2.5. Sprint shall provide to CLEC Recorded Usage Data for CLEC subscribers. Sprint shall not submit other CLEC local usage data as part of the CLEC Recorded Usage Data.
- 72.2.6. Sprint shall not bill directly to CLEC subscribers any recurring or non-recurring charges for CLEC's services to the subscriber except where explicitly permitted to do so within a written agreement between Sprint and CLEC.
- 72.2.7. Sprint will record 976/N11 calls and transmit them to the IP for billing. Sprint will not bill these calls to either the CLEC or the CLEC's end user.
- 72.2.8. Sprint shall provide Recorded Usage Data to CLEC billing locations as agreed to by the Parties.
- 72.2.9. Sprint shall provide a single point of contact to respond to CLEC call

usage, data error, and record transmission inquiries.

72.2.10. Sprint shall provide CLEC with a single point of contact and remote identifiers (IDs) for each sending location.

72.2.11. CLEC shall provide a single point of contact responsible for receiving usage transmitted by Sprint and receiving usage tapes from a courier service in the event of a facility outage.

72.2.12. Sprint shall bill and CLEC shall pay the charges for Recorded Usage Data. Billing and payment shall be in accordance with the applicable terms and conditions set forth herein.

### 72.3. Charges

72.3.1. Access services, including revenues associated therewith, provided in connection with the resale of services hereunder shall be the responsibility of Sprint and Sprint shall directly bill and receive payment on its own behalf from an IXC for access related to interexchange calls generated by resold or rebranded customers.

72.3.2. Sprint will be responsible for returning EMI records to IXCs with the proper EMI Return Code along with the Operating Company Number (OCN) of the associated ANI, (i.e., Billing Number).

72.3.3. Sprint will deliver a monthly statement for wholesale services in the medium (e.g.: NDM, paper, diskette, cartridge, magnetic tape, or CD-ROM) requested by CLEC as follows:

72.3.3.1. Invoices will be provided in a standard Carrier Access Billing format or other such format as Sprint may determine;

72.3.3.2. Where local usage charges apply and message detail is created to support available services, the originating local usage at the call detail level in standard EMI industry format will be exchanged daily or at other mutually agreed upon intervals, and CLEC will pay Sprint for providing such call detail;

72.3.3.3. The Parties will work cooperatively to exchange information to facilitate the billing of in and out collect and inter/intra-region alternately billed messages;

72.3.3.4. Sprint agrees to provide information on the end-user's selection of special features where Sprint maintains such information (e.g.: billing method, special language) when CLEC places the order for service;

72.3.3.5. Monthly recurring charges for Telecommunications Services sold pursuant to this Agreement shall be billed monthly in advance.

72.3.3.6. Sprint shall bill for message provisioning and, if applicable data tape charges, related to the provision of usage records. Sprint shall also bill CLEC for additional copies of the monthly invoice.

72.3.4. For billing purposes, and except as otherwise specifically agreed to in writing, the Telecommunications Services provided hereunder are furnished for a minimum term of one month. Each month is presumed to have thirty (30) days.

72.4. Central Clearinghouse & Settlement

72.4.1. Sprint and CLEC shall agree upon Clearinghouse and Incollect/Outcollect procedures.

72.4.2. Sprint shall settle with CLEC for both intra-region and inter-region billing exchanges of calling card, bill-to-third party, and collect calls under separately negotiated settlement arrangements.

72.5. Lost Data

72.5.1. Loss of Recorded Usage Data. CLEC Recorded Usage Data determined to have been lost, damaged or destroyed as a result of an error or omission by Sprint in its performance of the recording function shall be recovered by Sprint at no charge to CLEC. In the event the data cannot be recovered by Sprint, Sprint shall estimate the messages and associated revenue, with assistance from CLEC, based upon the method described below. This method shall be applied on a consistent basis, subject to modifications agreed to by Sprint and CLEC. This estimate shall be used to adjust amounts CLEC owes Sprint for services Sprint provides in conjunction with the provision of Recorded Usage Data.

72.5.2. Partial Loss. Sprint shall review its daily controls to determine if data has been lost. When there has been a partial loss, actual message and minute volumes shall be reported, if possible through recovery as discussed in 4.1.4.1 above. Where actual data are not available, a full day shall be estimated for the recording entity, as outlined in the following paragraphs. The amount of the partial loss is then determined by subtracting the data actually recorded for such day from the estimated total for such day.

72.5.3. Complete Loss. When Sprint is unable to recover data as discussed in 4.1.4.1 above estimated message and minute volumes for each loss consisting of an entire AMA tape or entire data volume due to its loss prior to or during processing, lost after receipt, degaussed before processing, receipt of a blank or unreadable tape, or lost for other causes, shall be reported.

72.5.4. Estimated Volumes. From message and minute volume reports for the entity experiencing the loss, Sprint shall secure message/minute counts for the four (4) corresponding days of the weeks preceding that in which the



loss occurred and compute an average of these volumes. Sprint shall apply the appropriate average revenue per message ("arpm") agreed to by CLEC and Sprint to the estimated message volume for messages for which usage charges apply to the subscriber to arrive at the estimated lost revenue.

72.5.5. If the day of loss is not a holiday but one (1) (or more) of the preceding corresponding days is a holiday, use additional preceding weeks in order to procure volumes for two (2) non-holidays in the previous two (2) weeks that correspond to the day of the week that is the day of the loss

72.5.6. If the loss occurs on a weekday that is a holiday (except Christmas and Mother's day), Sprint shall use volumes from the two (2) preceding Sundays.

72.5.7. If the loss occurs on Mother's day or Christmas day, Sprint shall use volumes from that day in the preceding year multiplied by a growth factor derived from an average of CLEC's most recent three (3) month message volume growth. If a previous year's message volumes are not available, a settlement shall be negotiated.

#### 72.6. Testing, Changes and Controls

72.6.1. The Recorded Usage Data, EMI format, content, and transmission process shall be tested as agreed upon by CLEC and Sprint.

72.6.2. Control procedures for all usage transferred between Sprint and CLEC shall be available for periodic review. This review may be included as part of an Audit of Sprint by CLEC or as part of the normal production interface management function. Breakdowns which impact the flow of usage between Sprint and CLEC must be identified and jointly resolved as they occur. The resolution may include changes to control procedures, so similar problems would be avoided in the future. Any changes to control procedures would need to be mutually agreed upon by CLEC and Sprint.

#### 72.6.3. Sprint Software Changes

72.6.3.1. When Sprint plans to introduce any software changes which impact the format or content structure of the usage data feed to CLEC, designated Sprint personnel shall notify CLEC no less than ninety (90) calendar days before such changes are implemented.

72.6.3.2. Sprint shall communicate the projected changes to CLEC's single point of contact so that potential impacts on CLEC processing can be determined.

72.6.3.3. CLEC personnel shall review the impact of the change on the entire control structure. CLEC shall negotiate any perceived problems with Sprint and shall arrange to have the data tested utilizing the modified software if required.

72.6.3.4. If it is necessary for Sprint to request changes in the schedule, content or format of usage data transmitted to CLEC, Sprint shall notify CLEC.

**72.6.4. CLEC Requested Changes:**

72.6.4.1. CLEC may submit a purchase order to negotiate and pay for changes in the content and format of the usage data transmitted by Sprint.

72.6.4.2. When the negotiated changes are to be implemented, CLEC and/or Sprint shall arrange for testing of the modified data.

**72.7. Information Exchange and Interfaces**

72.7.1. Product/Service Specific. Sprint shall provide a Telcordia standard 42-50-01 miscellaneous charge record to support the Special Features Star Services if these features are part of Sprint's offering and are provided for Sprint's subscribers on a per usage basis.

**72.7.2. Rejected Recorded Usage Data**

72.7.2.1. Upon agreement between CLEC and Sprint, messages that cannot be rated and/or billed by CLEC may be returned to Sprint via CDN or other medium as agreed by the Parties. Returned messages shall be sent directly to Sprint in their original EMI format utilizing standard EMI return codes.

72.7.2.2. Sprint may correct and resubmit to CLEC any messages returned to Sprint. Sprint will not be liable for any records determined by Sprint to be billable to a CLEC end user. CLEC will not return a message that has been corrected and resubmitted by Sprint. Sprint will only assume liability for errors and unguideables caused by Sprint.

**73. GENERAL NETWORK REQUIREMENTS**

73.1. Sprint shall provide repair, maintenance and testing for all resold Telecommunications Services and such UNEs that Sprint is able to test, in accordance with the terms and conditions of this Agreement.

73.2. During the term of this Agreement, Sprint shall provide necessary maintenance business process support as well as those technical and systems interfaces at Parity. Sprint shall provide CLEC with maintenance support at Parity.

73.3. Sprint shall provide on a regional basis, a point of contact for CLEC to report vital telephone maintenance issues and trouble reports twenty four (24) hours and seven (7) days a week.

73.4. Sprint shall provide CLEC maintenance dispatch personnel on the same schedule

that it provides its own subscribers.

- 73.5. Sprint shall cooperate with CLEC to meet maintenance standards for all Telecommunications Services and unbundled network elements ordered under this Agreement. Such maintenance standards shall include, without limitation, standards for testing, network management, call gapping, and notification of upgrades as they become available.
- 73.6. All Sprint employees or contractors who perform repair service for CLEC subscribers shall follow Sprint standard procedures in all their communications with CLEC subscribers. These procedures and protocols shall ensure that:
  - 73.6.1. Sprint employees or contractors shall perform repair service that is equal in quality to that provided to Sprint subscribers; and
  - 73.6.2. Trouble calls from CLEC shall receive response time priority that is equal to that of Sprint subscribers and shall be handled on a "first come first served" basis regardless of whether the subscriber is a CLEC subscriber or a Sprint subscriber.
- 73.7. Sprint shall provide CLEC with scheduled maintenance for resold lines, including, without limitation, required and recommended maintenance intervals and procedures, for all Telecommunications Services and network elements provided to CLEC under this Agreement equal in quality to that currently provided by Sprint in the maintenance of its own network. CLEC shall perform its own testing for UNEs.
- 73.8. Sprint shall give maximum advanced notice to CLEC of all non-scheduled maintenance or other planned network activities to be performed by Sprint on any network element, including any hardware, equipment, software, or system, providing service functionality of which CLEC has advised Sprint may potentially impact CLEC subscribers.
- 73.9. Notice of Network Event. Each party has the duty to alert the other of any network events that can result or have resulted in service interruption, blocked calls, or negative changes in network performance.
- 73.10. On all misdirected calls from CLEC subscribers requesting repair, Sprint shall provide such CLEC subscriber with the correct CLEC repair telephone number as such number is provided to Sprint by CLEC. Once the Electronic Interface is established between Sprint and CLEC, Sprint agrees that CLEC may report troubles directly to a single Sprint repair/maintenance center for both residential and small business subscribers, unless otherwise agreed to by CLEC.
- 73.11. Upon establishment of an Electronic Interface, Sprint shall notify CLEC via such electronic interface upon completion of trouble report. The report shall not be considered closed until such notification is made. CLEC will contact its subscriber to determine if repairs were completed and confirm the trouble no longer exists.

- 73.12. Sprint shall perform all testing for resold Telecommunications Services.
- 73.13. Sprint shall provide test results to CLEC, if appropriate, for trouble clearance. In all instances, Sprint shall provide CLEC with the disposition of the trouble.
- 73.14. If Sprint initiates trouble handling procedures, it will bear all costs associated with that activity. If CLEC requests the trouble dispatch, and either there is no trouble found, or the trouble is determined to be beyond the end user demarcation point, then CLEC will bear the cost.

## **74. MISCELLANEOUS SERVICES AND FUNCTIONS**

### **74.1. General**

74.1.1. To the extent that Sprint does not provide the services described in this Article 12 to itself, Sprint will use reasonable efforts to facilitate the acquisition of such services for or by CLEC through the existing service provider. CLEC must contract directly with the service provider for such services.

### **74.1.2. Basic 911 and E911 General Requirements**

74.1.2.1. Basic 911 and E911 provides a caller access to the appropriate emergency service bureau by dialing a 3-digit universal telephone number (911). Basic 911 and E911 access from Local Switching shall be provided to CLEC in accordance with the following:

74.1.2.2. E911 shall provide additional routing flexibility for 911 calls. E911 shall use subscriber data, contained in the ALI/DMS, to determine to which PSAP to route the call.

74.1.2.3. Basic 911 and E911 functions provided to CLEC shall be at Parity with the support and services that Sprint provides to its subscribers for such similar functionality.

74.1.2.4. Basic 911 and E911 access when CLEC purchases Local Switching shall be provided to CLEC in accordance with the following:

74.1.2.4.1. Sprint shall conform to all state regulations concerning emergency services.

74.1.2.4.2. For E911, Sprint shall use its service order process to update and maintain subscriber information in the ALI/DMS. Through this process, Sprint shall provide and validate CLEC subscriber information resident or entered into the ALI/DMS.

- 74.1.2.4.3. Sprint shall provide for overflow 911 traffic to be routed to Sprint Operator Services or, at CLEC's discretion, directly to CLEC operator services.
- 74.1.3. Basic 911 and E911 access from the CLEC local switch shall be provided to CLEC in accordance with the following:
- 74.1.3.1. If required by CLEC, Sprint, at CLEC's sole expense, shall interconnect direct trunks from the CLEC network to the E911 PSAP, or the E911 Tandems as designated by CLEC. Such trunks may alternatively be provided by CLEC.
- 74.1.3.2. In government jurisdictions where Sprint has obligations under existing agreements as the primary provider of the 911 System to the county (Host SPRINT), CLEC shall participate in the provision of the 911 System as follows:
- 74.1.3.2.1. Each party shall be responsible for those portions of the 911 System for which it has control, including any necessary maintenance to each party's portion of the 911 System.
- 74.1.3.2.2. Host SPRINT shall be responsible for maintaining the E-911 database. Sprint shall be responsible for maintaining the E-911 routing database.
- 74.1.4. If a third party is the primary service provider to a government agency, CLEC shall negotiate separately with such third party with regard to the provision of 911 service to the agency. All relations between such third party and CLEC are totally separate from this Agreement and Sprint makes no representations on behalf of the third party.
- 74.1.5. If CLEC or its Affiliate is the primary service provider to a government agency, CLEC and Sprint shall negotiate the specific provisions necessary for providing 911 service to the agency and shall include such provisions in an amendment to this Agreement.
- 74.1.6. Interconnection and database access shall be priced as specified in Part C.
- 74.1.7. Sprint shall comply with established, competitively neutral intervals for installation of facilities, including any collocation facilities, diversity requirements, etc.
- 74.1.8. In a resale situation, where it may be appropriate for Sprint to update the ALI database, Sprint shall update such database with CLEC data in an interval at Parity with that experienced by Sprint subscribers.
- 74.1.9. Sprint shall transmit to CLEC daily all changes, alterations, modifications,

and updates to the emergency public agency telephone numbers linked to all NPA NXX's. This transmission shall be electronic and be a separate feed from the subscriber listing feed.

74.1.10. Sprint shall provide to CLEC the necessary UNEs for CLEC to provide E911/911 services to government agencies. If such elements are not available from Sprint, Sprint shall offer E911/911 service for resale by CLEC to government agencies.

74.1.11. The following are Basic 911 and E911 Database Requirements

74.1.11.1. The ALI database shall be managed by Sprint, but is the property of Sprint and CLEC for those records provided by CLEC.

74.1.11.2. To the extent allowed by the governmental agency, and where available, copies of the SIG shall be provided within three business days from the time requested and provided on diskette, magnetic tape, or in a format suitable for use with desktop computers.

74.1.11.3. CLEC shall be solely responsible for providing CLEC database records to Sprint for inclusion in Sprint's ALI database on a timely basis.

74.1.11.4. Sprint and CLEC shall arrange for the automated input and periodic updating of the E911 database information related to CLEC end users. Sprint shall work cooperatively with CLEC to ensure the accuracy of the data transfer by verifying it against the SIG. Sprint shall accept electronically transmitted files or magnetic tape that conform to NENA Version #2 format.

74.1.11.5. CLEC shall assign an E911 database coordinator charged with the responsibility of forwarding CLEC end user ALI record information to Sprint or via a third-party entity, charged with the responsibility of ALI record transfer. CLEC assumes all responsibility for the accuracy of the data that CLEC provides to Sprint.

74.1.11.6. CLEC shall provide information on new subscribers to Sprint within one (1) business day of the order completion. Sprint shall update the database within two (2) business days of receiving the data from CLEC. If Sprint detects an error in the CLEC provided data, the data shall be returned to CLEC within two (2) business days from when it was provided to Sprint. CLEC shall respond to requests from Sprint to make corrections to database record errors by uploading corrected records within two (2) business days. Manual entry shall be allowed only in the event that the system is not functioning properly.

74.1.11.7. Sprint agrees to treat all data on CLEC subscribers provided

under this Agreement as confidential and to use data on CLEC subscribers only for the purpose of providing E911 services.

74.1.11.8. Sprint shall adopt use of a CLEC Code (NENA standard five-character field) on all ALI records received from CLEC. The CLEC Code will be used to identify the CLEC of record in LNP/INP configurations.

74.1.11.9. Sprint shall identify which ALI databases cover which states, counties or parts thereof, and identify and communicate a Point of Contact for each.

74.1.12. The following are basic 911 and E911 Network Requirements

74.1.12.1. Sprint, at CLEC's option, shall provide a minimum of two (2) E911 trunks per 911 switching entity, or that quantity which will maintain P.01 transmission grade of service, whichever is the higher grade of service. Where applicable these trunks will be dedicated to routing 911 calls from CLEC's switch to a Sprint selective router.

74.1.12.2. Sprint shall provide the selective routing of E911 calls received from CLEC's switching office. This includes the ability to receive the ANI of CLEC's subscriber, selectively route the call to the appropriate PSAP, and forward the subscriber's ANI to the PSAP. Sprint shall provide CLEC with the appropriate CLLI codes and specifications regarding the Tandem serving area associated addresses and meet-points in the network.

74.1.12.3. CLEC shall ensure that its switch provides an eight-digit ANI consisting of an information digit and the seven-digit exchange code. CLEC shall also ensure that its switch provides the line number of the calling station. Where applicable, CLEC shall send a ten-digit ANI to Sprint when there is an ANI failure the CLEC shall send the Central Office Trunk Group number in the Emergency Service Central Office (ESCO) format.

74.1.12.4. Each ALI discrepancy report shall be jointly researched by Sprint and CLEC. Corrective action shall be taken immediately by the responsible party.

74.1.12.5. Where Sprint controls the 911 network, Sprint should provide CLEC with a detailed written description of, but not limited to, the following information:

74.1.12.5.1. Geographic boundaries of the government entities, PSAPs, and exchanges as necessary.

- 74.1.12.5.2. LECs rate centers/exchanges, where "Rate Center" is defined as a geographically specified area used for determining mileage dependent rates in the Public Switched Telephone Network.
- 74.1.12.5.3. Technical specifications for network interface, Technical specifications for database loading and maintenance.
- 74.1.12.5.4. Sprint shall identify special routing arrangements to complete overflow.
- 74.1.12.5.5. Sprint shall begin restoration of E911 and/or E911 trunking facilities immediately upon notification of failure or outage. Sprint must provide priority restoration of trunks or networks outages on the same terms/conditions it provides itself and without the imposition of Telecommunications Service Priority (TSP).
- 74.1.12.5.6. Repair service shall begin immediately upon receipt of a report of a malfunction. Repair service includes testing and diagnostic service from a remote location, dispatch of or in-person visit(s) of personnel. Technicians will be dispatched without delay.
- 74.1.12.6. Sprint shall identify any special operator-assisted calling requirements to support 911.
- 74.1.12.7. Trunking shall be arranged to minimize the likelihood of central office isolation due to cable cuts or other equipment failures. There will be an alternate means of transmitting a 911 call to a PSAP in the event of failures.
- 74.1.12.8. Circuits shall have interoffice, loop and CLEC system diversity when such diversity can be achieved using existing facilities. Circuits will be divided as equally as possible across available CLEC systems. Diversity will be maintained or upgraded to utilize the highest level of diversity available in the network.
- 74.1.12.9. All 911 trunks must be capable of transmitting and receiving Baudot code or ASII necessary to support the use of Telecommunications Devices for the Deaf (TTY/TDDs).
- 74.1.13. Basic 911 and E911 Additional Requirements
- 74.1.13.1. All CLEC lines that have been ported via INP shall reach the correct PSAP when 911 is dialed. Sprint shall send both the ported



number and the CLEC number (if both are received from CLEC). The PSAP attendant shall see both numbers where the PSAP is using a standard ALI display screen and the PSAP extracts both numbers from the data that is sent.

74.1.13.2. Sprint shall work with the appropriate government agency to provide CLEC the ten-digit POTS number of each PSAP which sub-tends each Sprint selective router/911 Tandem to which CLEC is interconnected.

74.1.13.3. Sprint shall notify CLEC 48 hours in advance of any scheduled testing or maintenance affecting CLEC 911 service, and provide notification as soon as possible of any unscheduled outage affecting CLEC 911 service.

74.1.13.4. CLEC shall be responsible for reporting all errors, defects and malfunctions to Sprint. Sprint shall provide CLEC with the point of contact for reporting errors, defects, and malfunctions in the service and shall also provide escalation contacts.

74.1.13.5. CLEC may enter into subcontracts with third parties, including CLEC Affiliates, for the performance of any of CLEC's duties and obligations stated herein.

74.1.13.6. Sprint shall provide sufficient planning information regarding anticipated moves to SS7 signaling, for 911 services, for the next twelve (12) months.

74.1.13.7. Sprint shall provide notification of any impacts to the 911 services provided by Sprint to CLEC resulting from of any pending Tandem moves, NPA splits, or scheduled maintenance outages, with enough time to react.

74.1.13.8. Sprint shall identify process for handling of "reverse ALI" inquiries by public safety entities.

74.1.13.9. Sprint shall establish a process for the management of NPA splits by populating the ALI database with the appropriate new NPA codes.

#### 74.2. Directory Listings Service Requests

74.2.1. These requirements pertain to Sprint's Listings Service Request process that enables CLEC to (a) submit CLEC subscriber information for inclusion in Directory Listings databases; (b) submit CLEC subscriber information for inclusion in published directories; and (c) provide CLEC subscriber delivery address information to enable Sprint to fulfill directory distribution obligations.

74.2.2. When implemented by the Parties, Sprint shall accept orders on a real-time basis via electronic interface in accordance with OBF Directory Service Request standards within three (3) months of the effective date of this Agreement. In the interim, Sprint shall create a standard format and order process by which CLEC can place an order with a single point of contact within Sprint.

74.2.3. Sprint will provide to CLEC the following Directory Listing Migration Options, valid under all access methods, including but not limited to, Resale, UNEs and Facilities-Based:

74.2.3.1. Migrate with no Changes. Retain all white page listings for the subscriber in both DA and DL. Transfer ownership and billing for white page listings to CLEC.

74.2.3.2. Migrate with Additions. Retain all white page listings for the subscriber in DL. Incorporate the specified additional listings order. Transfer ownership and billing for the white page listings to CLEC.

74.2.3.3. Migrate with Deletions. Retain all white page listings for the subscriber in DL. Delete the specified listings from the listing order. Transfer ownership and billing for the white page listings to CLEC.

74.2.3.4. To ensure accurate order processing, Sprint or its directory publisher shall provide to CLEC the following information, with updates promptly upon changes:

74.2.3.4.1. A matrix of NXX to central office;

74.2.3.4.2. Geographical maps if available of Sprint service area;

74.2.3.4.3. A description of calling areas covered by each directory, including but not limited to maps of calling areas and matrices depicting calling privileges within and between calling areas;

74.2.3.4.4. Listing format rules;

74.2.3.4.5. Standard abbreviations acceptable for use in listings and addresses;

74.2.3.4.6. Titles and designations; and

74.2.3.4.7. A list of all available directories and their Business

Office close dates

- 74.2.4. Based on changes submitted by CLEC, Sprint shall update and maintain directory listings data for CLEC subscribers who:
  - 74.2.4.1. Disconnect Service;
  - 74.2.4.2. Change CLEC;
  - 74.2.4.3. Install Service;
  - 74.2.4.4. Change any service which affects DA information;
  - 74.2.4.5. Specify Non-Solicitation; and
  - 74.2.4.6. Are Non-Published, Non-Listed, or Listed.
- 74.2.5. Sprint shall not charge for storage of CLEC subscriber information in the DL systems.
- 74.2.6. CLEC shall not charge for storage of Sprint subscriber information in the DL systems.
- 74.3. Directory Listings General Requirements. CLEC acknowledges that many directory functions including but not limited to yellow page listings, enhanced white page listings, information pages, directory proofing, and directory distribution are not performed by Sprint but rather are performed by and are under the control of the directory publisher. CLEC acknowledges that for a CLEC subscriber's name to appear in a directory, CLEC must submit a Directory Service Request (DSR). Sprint shall use reasonable efforts to assist CLEC in obtaining an agreement with the directory publisher that treats CLEC at Parity with the publisher's treatment of Sprint.
  - 74.3.1. This § 74.3 pertains to listings requirements published in the traditional white pages.
  - 74.3.2. Sprint shall include in its master subscriber system database all white pages listing information for CLEC subscribers in Sprint territories where CLEC is providing local telephone exchange services and has submitted a DSR.
  - 74.3.3. Sprint agrees to include one basic White pages listing for each CLEC customer located within the geographic scope of its White Page directories, at no additional charge to CLEC. A basic White Pages listing is defined as a customer name, address and either the CLEC assigned number for a customer or the number for which number portability is provided, but not both numbers. Basic White Pages listings of CLEC customers will be interfiled with listings of Sprint and other LEC customers.

- 74.3.4. CLEC agrees to provide CLEC customer listing information, including without limitation directory distribution information, to Sprint, at no charge. Sprint will provide CLEC with the appropriate format for provision of CLEC customer listing information to Sprint. The parties agree to adopt a mutually acceptable electronic format for the provision of such information as soon as practicable. In the event OBF adopts an industry-standard format for the provision of such information, the parties agree to adopt such format.
- 74.3.5. Sprint agrees to provide White Pages database maintenance services to CLEC. CLEC will be charged a Service Order entry fee upon submission of Service Orders into Sprint's Service Order Entry (SOE) System, which will include compensation for such database maintenance services. Service Order entry fees apply when Service Orders containing directory records are entered into Sprint's SOE System initially, and when Service Orders are entered in order to process a requested change to directory records.
- 74.3.6. CLEC customer listing information will be used solely for the provision of directory services, including the sale of directory advertising to CLEC customers.
- 74.3.7. In addition to a basic White Pages listing, Sprint will provide, tariffed White Pages listings (e.g.: additional, alternate, foreign and non-published listings) for CLEC to offer for resale to CLEC's customers.
- 74.3.8. Sprint, or its directory publisher, agree to provide White Pages distribution services to CLEC customers within Sprint's service territory at no additional charge to CLEC. Sprint represents that the quality, timeliness, and manner of such distribution services will be at Parity with those provided to Sprint and to other CLEC customers.
- 74.3.9. Sprint agrees to include critical contact information pertaining to CLEC in the "Information Pages" of those of its White Pages directories containing information pages, provided that CLEC meets criteria established by its directory publisher. Critical contact information includes CLEC's business office number, repair number, billing information number, and any other information required to comply with applicable regulations, but not advertising or purely promotional material. CLEC will not be charged for inclusion of its critical contact information. The format, content and appearance of CLEC's critical contact information will conform to applicable Sprint directory publisher's guidelines and will be consistent with the format, content and appearance of critical contact information pertaining to all CLECs in a directory.
- 74.3.10. Sprint will accord CLEC customer listing information the same level of confidentiality that Sprint accords its own proprietary customer

listing information. Sprint shall ensure that access to CLEC customer proprietary listing information will be limited solely to those of Sprint and Sprint's directory publisher's employees, agents and contractors that are directly involved in the preparation of listings, the production and distribution of directories, and the sale of directory advertising. Sprint will advise its own employees, agents and contractors and its directory publisher of the existence of this confidentiality obligation and will take appropriate measures to ensure their compliance with this obligation. Notwithstanding any provision herein to the contrary, the furnishing of White Pages proofs to a CLEC that contains customer listings of both Sprint and CLEC will not be deemed a violation of this confidentiality provision.

74.3.11. Sprint will sell or license CLEC's customer listing information to any third parties unless CLEC submits written requests that Sprint refrain from doing so. Sprint and CLEC will work cooperatively to share any payments for the sale or license of CLEC customer listing information to third parties. Any payments due to CLEC for its customer listing information will be net of administrative expenses incurred by Sprint in providing such information to third parties. The parties acknowledge that the release of CLEC's customer listing to Sprint's directory publisher will not constitute the sale or license of CLEC's customer listing information causing any payment obligation to arise pursuant to this § 74.3.11.

74.4. Other Directory Services. Sprint will exercise reasonable efforts to cause its directory publisher to enter into a separate agreement with CLEC which will address other directory services desired by CLEC as described in this §74.4.2. Both parties acknowledge that Sprint's directory publisher is not a party to this Agreement and that the provisions contained in this § 74.4.2 are not binding upon Sprint's directory publisher.

74.4.1. Sprint's directory publisher will negotiate with CLEC concerning the provision of a basic Yellow Pages listing to CLEC customers located within the geographic scope of publisher's Yellow Pages directories and distribution of Yellow Pages directories to CLEC customers.

74.4.2. Directory advertising will be offered to CLEC customers on a nondiscriminatory basis and subject to the same terms and conditions that such advertising is offered to Sprint and other CLEC customers. Directory advertising will be billed to CLEC customers by directory publisher.

74.4.3. Directory publisher will use commercially reasonable efforts to ensure that directory advertising purchased by customers who switch their service to CLEC is maintained without interruption.

74.4.4. Information pages, in addition to any information page or portion of an information page containing critical contact information as described

above in § 74.3.9 may be purchased from Sprint's directory publisher, subject to applicable directory publisher guidelines, criteria, and regulatory requirements.

74.4.5. Directory publisher maintains full authority as publisher over its publishing policies, standards and practices, including decisions regarding directory coverage area, directory issue period, compilation, headings, covers, design, content or format of directories, and directory advertising sales.

74.5. Directory Assistance Data. This section refers to the residential, business, and government subscriber records used by Sprint to create and maintain databases for the provision of live or automated operator assisted Directory Assistance. Directory Assistance Data is information that enables telephone exchange CLECs to swiftly and accurately respond to requests for directory information, including, but not limited to name, address and phone numbers. Under the provisions of the Act and the FCC's Interconnection order, Sprint shall provide unbundled and non-discriminatory access to the residential, business and government subscriber records used by Sprint to create and maintain databases for the provision of live or automated operator assisted Directory Assistance. This access shall be provided under separate contract.

74.6. Systems Interfaces and Exchanges

74.6.1. Directory Assistance Data Information Exchanges and Interfaces

74.6.1.1. Subscriber List Information

74.6.1.1.1. Sprint shall provide to CLEC, within sixty (60) days after the Approval Date of this Agreement, or at CLEC's request, all published Subscriber List Information (including such information that resides in Sprint's master subscriber system/accounts master file for the purpose of publishing directories in any format as specified by the Act) via an electronic data transfer medium and in a mutually agreed to format, on the same terms and conditions and at the same rates that the Sprint provides Subscriber List Information to itself or to other third parties. All changes to the Subscriber List Information shall be provided to CLEC pursuant to a mutually agreed format and schedule. Both the initial List and all subsequent Lists shall indicate for each subscriber whether the subscriber is classified as residence or business class of service.

74.6.1.1.2. CLEC shall provide directory listings to Sprint pursuant to the directory listing and delivery requirements in the approved OBF format, at a mutually agreed upon

timeframe. Other formats and requirements shall not be used unless mutually agreed to by the parties.

74.7. Listing Types

LISTED	The listing information is available for all directory requirements.
NON-LISTED	The listing information is available to all directory requirements, but the information does not appear in the published street directory.
NON-PUBLISHED	A directory service may confirm, by name and address, the presence of a listing, but the telephone number is not available. The listing information is not available in either the published directory or directory assistance.

## **PART J REPORTING STANDARDS**

### **75. GENERAL**

75.1. Sprint shall satisfy all service standards, intervals, measurements, specifications, performance requirements, technical requirements, and performance standards (Performance Standards) that are specified in this agreement or are required by law or regulation. In addition, Sprint's performance under this Agreement shall be provided to CLEC will be at Parity with the performance Sprint provides itself for like service(s).

### **76. PARITY AND QUALITY MEASUREMENTS**

76.1. Sprint will develop self-reporting capabilities comparing Sprint results with CLEC results for the following measures of service parity within six (6) months of the Effective Date:

76.1.1. Percentage of Commitment Times Met - Service Order

76.1.2. Percentage of Commitment Times Met - Trouble Report

76.1.3. Percent Repeated Trouble Reports

76.1.4. Average Receive to Clear

76.1.5. Percentage of Installed Orders without Repair in the first five (5) days

76.2. In the event CLEC chooses to utilize the Sprint operator service platform the following measures will be implemented within six (6) months of the date of first use by CLEC:

76.2.1. Average Toll Answer Time; and

76.2.2. Average Directory Assistance Answer Time.

76.3. All above measures will be implemented in a manner that is consistent with the current measures Sprint makes of its own performance.



IN WITNESS WHEREOF, each of the Parties has caused this Agreement to be executed by its duly authorized representatives.

**"Sprint"**

SPRINT-FLORIDA,  
INCORPORATED

By:

*William E. Cheek*

Name  
(typed):

William E. Cheek

Title:

V.P. Sales and Acct. Mgmt.

Date:

4/14/00

**"CLEC"**

USA DIGITAL, INC.

By:

*Kenneth D. Allen*

Name  
(typed):

Kenneth D. Allen

Title:

V.P. Operations

Date:

4-12-99