

State of Florida



Public Service Commission

CAPITAL CIRCLE OFFICE CENTER • 2540 SHUMARD OAK BOULEVARD
TALLAHASSEE, FLORIDA 32399-0850

-M-E-M-O-R-A-N-D-U-M-

DATE: May 19, 2014
TO: Carlotta Stauffer, Commission Clerk, Office of Commission Clerk
FROM: Sonica C. Bruce, Economic Analyst, Division of Economics *SH APC*
RE: Docket No. 130265 - WU - Application for staff-assisted rate case in Charlotte County by Little Gasparilla Water Utility, Inc.

The attached documents was sent from the Division of Economics on May 16, 2014.
Please incorporate the documents into the docket file.

RECEIVED-FPSC
14 MAY 19 AM 9:34
COMMISSION
CLERK

Clerk's Office

Response to PSC Staff's second Data Request

Dated April 30, 2014

Original filing
is missing
9) - 12)
CLK | *[Signature]*

- 1) Included is the "Utility System Asset Purchase and Sales Agreement" Adopted June 19, 1995 (attachment "A") I could not find the "APPENDICES" After this date we added 100,000 gal. In concrete storage and added water lines to the north.(Noted on Maps #19b)
- 2) This Purchase included all infrastructures up to each meter. All wells, Property, manufacturing equipment, easements, and permits. Everything to do with the Utility.
- 3) Utility Service Boats(included #3 &3E)
- 4) Short Term Pro Forma? This answer all goes back to funding! LGWU has been spending every spare penny towards the interconnect with CCU. I hope by the time you receive this response that bank financing will be in place. Then LGWU will take it first draw on the loan and reimburse expenders/accounts payable to date of over \$60,000. I have located both the backhoe and Golf cart but that doesn't mean they will be available when LGWU has funding. We will know in two weeks. Generator work is scheduled for June 5th. This has a leaky exhaust manifold and has gotten worse. The backhoe we have located as the best deal is in Jacksonville Fl. For \$22,000.

We will need to transport to Englewood, \$1,500, then \$600 for barging. For a total of \$24,100. This is not a done deal but a good possibility.

- 5) Office Expenses (included #5)
- 6) Insurance Expenses (included #6A&6B)
- 7) SEP (included #7)
- 8) Interconnect Effect on Expenses. (a) These numbers were put together by Charlotte County Consultancies but are really strait forward, with a few variables. 2012 LGWU's electric bill was \$19,000. We feel comfortable that we can run the remaining electrical demand for \$4,000 per. year and this is a cost savings of \$15,000. (b) This is a variable and everyone agrees to wait and see. Because of our variation with peak flows and our empty months, this will need to be determined at a later date? We could go spend a considerable amount of money on the worst case scenario or wait and see. If needed included is a proposal from RC Beach and Associates for an injection system. (\$18,765.00) (c) 2012 Equipment Repair was \$19,000 and these repairs had to do with the Manufacturing of water. So if we alleviate Manufacturing water, repair will disappear as well. Saving \$19,000 that year. (d) (attached # 8d) So the DEP has determined license/operator will be responsible for distribution Therefore, operators expense should be left in at \$7,500 (e) Last time we replaced ½ at

We have been trying to obtain an interconnect from Englewood Water(EWWD) as well but were unable to obtain permission from DEP Parks and Rec. Wheeling Charge would have been with Bocilla Utilities. This option was NOT cost effective. \$3.00 per thousand to EWWD \$2.60 and then 7000 ft of 8" Extension. CCU became the most cost effective.

- 13) Financing for Capital improvements? Should know shortly. Will keep you informed.
- 14) Rate Case Expense? (attachment # 14) Total to date and est. for completion. Total \$15,184.61
- 15) Contractual Services Testing & Lab (account 635) Yes the DEP required all testing. LGWU exceed its MCL on Sodium and Chlorides. In order to remove the additional testing LGWU had to remain under the MCL for one year to return to normal testing requirements. We did this and have returned to our normal required testing.
- 16) Contractual Services (Other Account 636) No we just executed this agreement in 2014 (attachment 16) (\$189.50 per year)
- 17) Unaccounted Water? Our records on the same 12 month shows a difference of 607,686 / 6% (included #17a) but after reviewing I think you might be correct. We change out our meters once we see they are not working and could lose as much as a quarter of usage. In 2013 we

have replaced approximately 25 meters. LGWU has wanted to switch over to remote read but it is very costly. This would allow weekly drive by for meter accuracy. Also for leak detection or abnormal usage. Proposal included from Blu Tower for \$24,914.63 (attachment # 17b) the first year and includes 100 meters. LGWU would like to phase this in over a four year period. With an additional 100 meters per year for 3 years. Cost to an additional \$20,000 per year. Total of \$84,914.63.

- 18) Sanitary Survey Reports Yes all issues have been resolved except, I will order safety suits for this year's inspection, if we don't have the interconnect by then.
- 19) Systems Maps; included (attachment #19 a & b)
- 20) Remaining Facilities after Interconnection. As stated before we will be utilizing this structure as our island facility to include: Cl2 injection system, in line pony pumps if required, work shop, meter bench test, repairs part inventory, equipment storage, refrigerator, and RESTROOM. Anything and everything.
- 21) DEP Permitting? Permit application #
- 22) DEP Permitting Cost. LGWU presently has \$53,424.08 and expect to spend an additional \$51,700.00 to completion. Total of \$105,125.08 (attachment # 22)
- 23) Interconnection Bids. (Attachment #23) there are only two. LGWU will obtain at least other one or two bids

shortly. Also included is a set of plans. Please note: NOT before included was the line extension to the north. So our low bid as of 4/14/14 for CCU/LGWU interconnect is \$560,200.00 Then our line extension North at \$69,550.00 (attachment #23a) #23b is an estimate at \$612,000.00 just for the drill? Rebuild existing Building (attachment #23b-1 & -2)

24) Meter Replacement? The only new meters are the ones we replace. A lot of the meters are original (27 years) and this might help answer question # 17. Another reason to start switching over to Remote Read.

25) Easements? Again this has to do with being on the Island. This island was developed with very few North/South (ROW). Over the years homeowners have giving permission to cross their property so there neighbor could have water. There are over 52 different lots that have granted permission. Most of them were for our expansion in 2000. I have been working on an easement since 2006 that will allow LGWU to do its final Line extension of 2,000 LF to the north. Total cost of easements, on the Island exceeds \$30,000 in discounted water connection, connections, and cash. (Attachment #25) I am also permitting this line along with the interconnect. There are 6 homes wanting service at this time. They are in my CA and I must provide service. The

easement at the attorney's office as of today for North line and executed for CCU interconnects. (attachment #25)

- 26) Meter Problems? Please remember this is a barrier island that in the highest elevations might be 6 feet. We sometimes will estimate one quarter due to the meter being under water, max 10 meters. This is something that can be resolved with remote read meters as well.
- 27) HOA Wastewater? Hideaway has 102 units and Placida has 30 units = 132 condos Yes LGWU provides water service.
- 28) Emergency Interconnection? This was a onetime deal. Our Manufacturing pump broke a piston rod and it was an extensive shut down. The only way to get water was through the state park and the Governor allowed for emergence purposes only.
- 29) Purchased Water? No

***Please make note! *** I have a correction to make. When the auditors were here, I was asked "How much does it cost to hook up one meter?" I responded \$500. And I was wrong! Attached is a material list that it takes to install one meter. I was only off by 100% the real number comes up to \$964.34 if there are no problems. (attachment "Please make note")

A

**UTILITY SYSTEM ASSET
PURCHASE AND SALE AGREEMENT**



By and Between

SEASIDE SERVICE SYSTEM, INC.

and

SEASIDE/LITTLE GASPARILLA UTILITY, INC.



ADOPTED JUNE 19, 1995

TABLE OF CONTENTS

ARTICLE I

DEFINITIONS AND CONSTRUCTION

SECTION

1.01	DEFINITIONS
1.02	CONSTRUCTION AND INTERPRETATION
1.03	INCORPORATION
1.04	SECTION HEADINGS

ARTICLE II

REPRESENTATIONS

2.01	REPRESENTATIONS OF SEASIDE/LITTLE
2.02	REPRESENTATIONS OF SERVICE

ARTICLE III

PURCHASE AND SALE OF ASSETS

3.01	PURCHASE AND SALE OF ASSETS
3.02	PURCHASED ASSETS
3.03	PURCHASE PRICE

ARTICLE IV

CONDITIONS PRECEDENT TO CLOSING

4.01	ENVIRONMENTAL AUDIT
4.02	SURVEY
4.03	TITLE INSURANCE

ARTICLE V

CLOSING PROCEDURES

5.01	CLOSING DATE AND PLACE
5.02	RECORDING FEES AND DOCUMENTARY TAXES
5.03	PROPERTY TAXES
5.04	ACCOUNTS RECEIVABLE
5.05	CONNECTION CHARGES
5.06	PROFESSIONAL FEES; COSTS
5.07	RISK OF LOSS
5.08	PROCEEDS OF SALE; CLOSING PROCEDURE

ARTICLE VI

GENERAL PROVISIONS

6.01	INDUCEMENT FOR SEASIDE/LITTLE TO EXECUTE
6.02	RIGHT TO ENTER
6.03	EMPLOYMENT PREFERENCE
6.04	CONDUCT BETWEEN EXECUTION AND CLOSING
6.05	TIME IS OF THE ESSENCE
6.06	APPLICABLE LAW; JURISDICTION AND VENUE
6.07	FAILURE OF PERFORMANCE
6.08	NOTICE
6.09	ASSIGNMENT
6.10	AMENDMENTS AND WAIVERS
6.11	TERMS READ IN CONCERT WITH AGREEMENT
6.12	AGREEMENT TO BENEFIT ONLY PARTIES HERETO
6.13	EXECUTION OF ADDITIONAL DOCUMENTS
6.14	ENTIRE AGREEMENT

APPENDICES

APPENDIX

A	Real Property to be Conveyed to SEASIDE/LITTLE
B	Easement Interests to be Conveyed to SEASIDE/LITTLE
C	Schedule of Plans and Specifications
E	Schedule of Permits
F	Inventory
G	Schedule Detailing Plant, Property, Equipment and Depreciation
H	Schedule of Operating and Vendor Contracts
K	Schedule of Continuing or Outstanding Potable Utility and Wastewater Service Obligations
L	Schedule of Executory Agreements (Other than Developer Agreements)
M	Schedule of Current Rates, Fees and Charges Imposed by SEASIDE/LITTLE
N	Schedule of Insurance Policies
P	Permitted Title Exceptions
Q	Form of Documents for Closing
R	Joint Action of Directors and Shareholders
S	Joint Action of Partners
V	Notes and accounts receivable assigned to SEASIDE/LITTLE
X	Map of Utility System

**UTILITY SYSTEM ASSET
PURCHASE AND SALE AGREEMENT**

THIS AGREEMENT, is made and entered into as of this 19th day of June, 1995, by and between SEASIDE SERVICE SYSTEM, INC., ("SERVICE") a Florida corporation and SEASIDE/LITTLE GASPARILLA UTILITY, INC., ("SEASIDE/LITTLE") a Florida corporation.

WITNESSETH:

WHEREAS, SERVICE owns and operates a potable water system which provides service to unincorporated portions of Charlotte County, Florida; and

WHEREAS, SEASIDE/LITTLE was created to provide potable water, infrastructure and service; and

WHEREAS, upon acquisition of the assets of SERVICE, SEASIDE/LITTLE has the ability and authority to provide service to SERVICE's service area; and

WHEREAS, SEASIDE/LITTLE desires to purchase all or substantially all of the assets of SERVICE and SERVICE is willing to sell those assets to the SEASIDE/LITTLE;

NOW, THEREFORE, in consideration of the mutual promises, covenants, representations and agreements contained herein, together with \$10 and other good and valuable consideration exchanged among the parties, the parties to this Agreement do undertake, promise and agree for themselves, their permitted successors and assigns as follows:

ARTICLE I
DEFINITIONS AND CONSTRUCTION

SECTION 1.01. DEFINITIONS. As used in this Agreement, the following terms shall have the meanings as defined unless the context requires otherwise:

“Agreement” means this Utility System Asset Purchase and Sale Agreement, including any amendments and supplements hereto executed and delivered in accordance with the terms hereof.

“Board” means the Board of Directors of the SEASIDE/LITTLE GASPARILLA UTILITY, INC.

“SEASIDE/LITTLE” means the SEASIDE/LITTLE GASPARILLA UTILITY, INC., a Florida corporation.

“Easements” means all rights, privileges, easements, licenses, prescriptive rights, rights-of-ways and rights to use public and private roads, highways, streets and other areas owned or used by SERVICE in connection with the construction, reconstruction, installation, expansion, maintenance and operation of the utility system and the Purchased Assets.

“Purchased Assets” means all or substantially all of the assets of SERVICE as described and referenced in Section 3.02(A) hereof.

“SERVICE” means SEASIDE SERVICE SYSTEM, INC., a Florida corporation.

SECTION 1.02. CONSTRUCTION AND INTERPRETATION.

(A) Words that indicate a singular number shall include the plural in each case and vice versa and words that import a person shall include firms and corporations.

(B) The terms “herein”, “hereunder”, “hereby”, “hereof” and any similar terms, shall refer to this Agreement; the term “heretofore” shall mean before the date of execution of this Agreement; and the term “hereafter” shall mean after the initial date of execution of this Agreement.

(C) Words that reference only one gender shall include all genders.

(D) This Agreement shall be construed as resulting from joint negotiation and authorship. No part of this Agreement shall be construed as the product of any one of the parties hereto.

SECTION 1.03. INCORPORATION. The appendices hereto and each of the documents referred to therein are incorporated herein and made a part hereof in their entirety by reference.

SECTION 1.04. SECTION HEADINGS. Any headings preceding the texts of the several Articles and Sections in this Agreement and any table of contents or marginal notes appended to copies hereof, shall be solely for the convenience of reference and shall neither constitute a part of this Agreement nor affect its meaning, construction or effect.

ARTICLE II REPRESENTATIONS

SECTION 2.01. REPRESENTATIONS OF SEASIDE/LITTLE. SEASIDE/LITTLE makes the following representations:

(A) SEASIDE/LITTLE is duly organized and validly existing as a corporation of the State of Florida.

(B) SEASIDE/LITTLE has full power and authority to enter into the transactions contemplated by this Agreement.

(C) SEASIDE/LITTLE has fulfilled and complied with all legal requirements including, but not limited to, the provisions of the laws of the State of Florida material to the performance of its obligations under this Agreement. The Board has duly authorized the execution and delivery of this Agreement and assuming the due authorization, execution and delivery by other parties hereto, this Agreement constitutes a valid and legally binding obligation of SEASIDE/LITTLE, enforceable in accordance with its terms, except to the extent that the enforceability thereof may be limited by any applicable bankruptcy, insolvency, reorganization or other similar laws affecting creditors' rights generally, or by the exercise of judicial discretion in accordance with general principles of equity.

(D) To the best of SEASIDE/LITTLE's knowledge and belief after due inquiry, the authorization, execution and delivery of this Agreement and the compliance by SEASIDE/LITTLE with the provisions hereof will not conflict with or constitute a material breach of default under, and existing law, court or administrative regulation, decree, order, or any provision of the Constitution, or the laws of the State of Florida relating to SEASIDE/LITTLE or its affairs, or any ordinance, resolution, agreement, lease, bond indenture, or other instrument to which SEASIDE/LITTLE is subject or by which it is bound.

(E) There is no action, suit, or investigation at law or in equity before or by any court, public board or body pending, or to the best of SERVICE's and SEASIDE/LITTLE's knowledge and belief, wherein a favorable decision, ruling or finding would adversely affect the transactions contemplated hereby, or which, in any way, would adversely affect the validity of this Agreement or any agreement or instrument to which SERVICE or SEASIDE/LITTLE are a party and which is contemplated for use in the consummation of the transactions contemplated hereby.

(F) SEASIDE/LITTLE has not dealt with any broker, salesman or finder in connection with the transactions contemplated herein and no sales commissions or finder's fees are due or payable as a result hereof.

SECTION 2.02. REPRESENTATIONS OF SERVICE. SERVICE make the following representations:

(A) SEASIDE SERVICE SYSTEM, INC. is a corporation duly organized, validly existing in and good standing in the State of Florida, authorized to do business in the State, and has all requisite corporate power and authority to enter into and fully perform this Agreement.

(B) All necessary corporate action on the part of SERVICE relating to the authorization of SERVICE's execution and delivery of this Agreement and SERVICE's performance of its duties and obligations contained herein shall have been duly taken, and this Agreement will be valid and enforceable against SERVICE, in accordance with its terms, except to the extent that the enforceability thereof may be limited by any applicable bankruptcy, insolvency, reorganization or other similar laws affecting creditors' rights generally, or by the exercise of judicial discretion in accordance with the general principles of equity. As an inducement for SEASIDE/LITTLE to execute this Agreement, all of the shareholders and directors of SERVICE shall execute the Joint Action of Directors and Shareholders attached hereto as Appendix R.

(C) There are no actions, suits, or proceedings pending or, to the knowledge and belief of SERVICE, threatened against or affecting SERVICE, at law or in equity or before any federal, state, municipal, or other governmental department, commission, board, bureau, agency or instrumentality wherein any favorable decision, ruling or finding would adversely affect the transactions contemplated hereby or which in any way would adversely affect the validity of this Agreement or other agreement or instrument to which SERVICE is a party and which is used or contemplated for use in the consummation of the transactions contemplated hereby.

(D) To the best of SERVICE's knowledge and belief and after due inquiry, neither the execution and delivery of this Agreement, nor the consummation of the transactions contemplated, nor compliance with the terms and provisions of such instruments will violate the provisions of any applicable law or any applicable order or regulation of any governmental authority having jurisdiction over SERVICE and will not conflict with or result in a material breach of any terms, conditions or provisions of any agreement or instrument to which SERVICE is now a party, or constitute a default thereunder, or which may not be assigned in the ordinary course of business.

(E) SERVICE has good and marketable fee simple title to, or has control over, the Purchased Assets and, at closing, shall deliver sole and exclusive possession of the Purchased Assets to SEASIDE/LITTLE free and clear of all encumbrances subject only to the title exceptions permitted hereunder to appear on an owner's title insurance policy issued thereon, none of which will prohibit or limit the use of the Purchased Assets as a publicly owned or operated utility system.

(F) SERVICE has not dealt with any broker, salesman or finder in connection with the transactions contemplated herein and no sales commissions or finder's fees are due or payable as a result hereof.

(G) The real property identified in Appendix A hereof represents all real property owned, used or controlled by SERVICE in the operation of the utility system and the Purchased Assets.

(H) The Easements identified in Appendix B hereto represent all easements owned or used by SERVICE for use in connection with the construction, reconstruction, installation, expansion, maintenance and operation of the utility system and the Purchased Assets.

(I) SERVICE possesses an enforceable easement interest in each Easement shown on Appendix B hereto and has the ability to assign them to SEASIDE/LITTLE at closing.

(J) Appendix C, attached hereto, is a schedule of all plans and specifications which describe SERVICE's plants and facilities as currently built.

(K) Appendix X, attached hereto, is a map(s) of the SERVICE system which shows all facilities, appurtenances as currently constructed and other purchased assets and is a true and correct representation thereof.

(L) Appendix E, attached hereto, is a schedule of all current or active permits, applications or documents together with effective dates and any expiration dates which demonstrate approval of SERVICE's treatment system by all applicable governmental authorities.

(M) Appendix F, attached hereto, is a complete inventory of all equipment, vehicles, tools, parts, laboratory equipment, office equipment and other personal property owned by SERVICE or used by SERVICE in connection with the operation system.

(N) Appendix G, attached hereto, is a schedule detailing all plant, property, equipment and depreciation of the Purchased Assets.

(O) Appendix H, attached hereto, is a schedule of all operating and vendor contracts which may be assumed by SEASIDE/LITTLE at closing.

(P) Appendix J, attached hereto, is a schedule of all executory agreements, sometimes referred to as developer agreements, sometimes referred to as developer agreements, entered into by and between SERVICE and owners or developers of real property for the provision of services.

(Q) Appendix K, attached hereto, is a schedule, with respect to all executory agreements under which SERVICE has any continuing or outstanding service obligations, which shows the total number of (1) contractual connections; (2) connections paid for and unconnected; and (3) connections paid for but not yet connected, for which quarterly base facility charges are not being paid.

(R) Appendix L, attached hereto, is a schedule of all other agreements entered into between SERVICE and third parties which would or might be considered to be an encumbrance upon the Purchased Assets, including without limitation, any leasehold agreements or oral agreements. Any and all oral agreements have been reduced to writing, signed by the parties, and identified by SERVICE on said schedule.

(S) Appendix M, attached hereto, is a schedule of all rates, fees and charges that SERVICE are currently authorized to impose and the authority therefore.

(T) Appendix N, attached hereto, is a schedule of any and all insurance policies currently enforceable that cover SERVICE as they may relate to the Purchased Assets. Such appendix indicates the name and address of each carrier, the policy number and the type of coverage provided.

(U) From and after the date of the execution of this Agreement, SERVICE will not, without the prior written consent of SEASIDE/LITTLE, dispose of or encumber any of the Purchased Assets, with the exception of any transactions occurring in the ordinary course of SERVICE's business.

(V) From and after the date of the execution of this Agreement, there will be no material depletion of the Purchased Assets, nor any material change in the condition of the Purchased Assets, and the system and Purchased Assets will be properly maintained within the custom and usage of the industry up until and through closing.

(W) SERVICE have not been cited nor notified, and is not, after due inquiry, aware of any violation, nor any action or intention by regulators to cite or notify SERVICE of a violation, of any governmental rule, regulation, permitting condition, or other governmental requirement of any type or nature applicable to the ownership, maintenance, construction or operation of a system, nor are SERVICE aware of any conditions which by reason of passing of time or the giving of notice would constitute such a violation.

(X) No employment contract exists under which SERVICE are the employers, that cannot be canceled within 30 days notice or less, and without payment of any consideration of such cancellation.

(Y) To the best of its knowledge and belief, and in reliance on the special exceptions obtained by SERVICE and provided to SEASIDE/LITTLE, the SERVICE system is located on real property which has been zoned by appropriate authorities under zoning certificates which will permit the use of such parcels for utility purposes.

(Z) To the best of its knowledge and belief after due inquiry, the real property to be conveyed to SEASIDE/LITTLE hereunder is in compliance with, and SERVICE have not violated, in connection with their ownership, use, maintenance or operation of the system, applicable environmental, federal, state, country or local laws relating to pollution or protection of the environment, including but not limited to, the Comprehensive Environmental Response Compensation and Liability Act of 1980 as amended by the Superfund Amendments and

Reauthorization Act of 1986, the Resource Conservation and Recovery Act, or the Toxic Substance Control Act. SERVICE have not authorized the placing or depositing of hazardous substances on the real estate to be conveyed to SEASIDE/LITTLE except, if at all, in accordance with applicable law, and SERVICE have no actual knowledge of any hazardous substance having been, or currently being, placed or deposited on said real property except in a lawful manner.

(AA) There are no facts known to SERVICE materially affecting the operation or value of the utility system or Purchased Assets which are not readily observable or which have not been disclosed to SEASIDE/LITTLE.

ARTICLE III

PURCHASE AND SALE OF ASSETS

SECTION 3.01. PURCHASE AND SALE COVENANT. At the closing, SEASIDE/LITTLE shall purchase and SERVICE shall sell and convey the Purchased Assets to SEASIDE/LITTLE upon the terms and subject to the conditions set forth in this Agreement.

SECTION 3.02. PURCHASED ASSETS.

(A) The Purchased Assets shall include those assets, business properties, and rights both tangible and intangible, that SERVICE owns or in which it has or hereafter acquires an interest, including the following:

(1) All real property and interest, whether recorded in the public records or not, in real property owned or controlled by SERVICE or held in trust for SERVICE.

(2) All plant facilities of every kind and description whatsoever including without limitation, all trade fixtures, leasehold improvements, , pumps, generators, controls, tanks, transmission pipes or facilities, valves, meters, service connections, spare equipment and parts, and all other physical facilities and property installations used for the operation of the system by SERVICE, together with an assignment of all third party warranties currently in effect that relate to completed or in progress construction and all potable water system and related costs.

(3) SERVICE's inventory, including all equipment, vehicles, tools, parts, laboratory equipment, and other personal property owned or used by SERVICE in connection with the operation of the system more particularly described, but not limited to those described in Appendix F of this Agreement.

(4) All easements and other rights in favor of SERVICE, including but not limited to, the Easements more particularly described in Appendix B of this Agreement, and all other rights, privileges, easements, licenses, prescriptive rights, right-of-ways, permits, leaseholds, grants, consents, immunities and rights to use public and private roads and other areas owned by SERVICE for the construction, reconstruction, maintenance and operation of the system. Upon closing, this agreement shall operate as an assignment of all such rights, however, at SEASIDE/LITTLE's request, SERVICE shall execute written assignments of such rights.

(5) All current customer records and supplier lists, as-built surveys and water plans, engineering and other drawings, designs, blueprints, plans and specifications, annual reports filed with Charlotte County for the past two (2) years, system monthly operating reports for the past two (2) years, maintenance manuals, operating manuals and 1993 and 1994 operating budgets.

(6) All necessary regulatory approvals subject to all conditions, limitations or restrictions contained therein; all existing permits and other governmental authorizations and approvals of any kind necessary to construct, operate, expand and maintain the utility system according to all governmental requirements, as more specifically described in Appendix E to this Agreement.

(7) Rights and obligations of SERVICE under existing agreements and contracts, limited to those described in Appendices H, K, and L; which SEASIDE/LITTLE shall assume at closing, except those obligations which are specifically excluded elsewhere herein.

(8) All choices in action, which specifically relate to the assets purchased from SERVICE, including but not limited to, warranty claims, claims for damages, the rights to sue for any past infringements, or other causes of action relating to the assets purchased from SERVICE. This provision does not include, however, personal claims of SERVICE.

(9) All cash or accounts which represent customer service security deposits or other advance deposits and/or payments which are or maybe subject to refund to customers, developers, or others, exclusive of any interim rate escrow's.

(10) All computer records and use of all computer software which is or was used in the operations of SERVICE for billing or customer record keeping purposes. The use of the software is for recovery of data stored in computers, once the data has been transferred to SEASIDE/LITTLE's computers, SEASIDE/LITTLE will return all software owned by SERVICE.

(11) All notes and accounts receivable (excluding connection charge notes receivable) of SERVICE listed in Appendix V.

(B) The Purchased Assets do not and shall not include the Excluded Assets.

SECTION 3.03. PURCHASE PRICE.

(A) The purchase price shall be One Million One Hundred Fifty Thousand Dollars (\$1,150,000.) payable by the assumption of a \$150,000 note to Peninsula Bank, a \$100,000 note to Dugald McNeill, notes totaling \$125,000 to Cape Hart Company and a promissory note of \$775,000 secured by a mortgage on the property at closing, subject to the adjustments and prorations as provided for herein and as provided for as follows:

(1) SERVICE shall be reimbursed at closing for its reasonable, actual and verifiable necessarily incurred professional fees and expenses (exclusive of ordinary, everyday fees and expenses) incurred by it from and after August 1, 1995, through the date of closing, which would normally be capitalized by SERVICE and recovered through the rate.

(B) The terms of the notes are payable as follows:

Note to SERVICE SYSTEM, INC.. in the principal sum of Seven Hundred Seventy-Five Thousand Dollars (\$775,000) together with interest at the rate of seven (7%) per annum until maturity in monthly payments for a period of thirty years with a balloon payment in ten years.

ARTICLE IV
CONDITIONS PRECEDENT TO CLOSING

SECTION 4.01. ENVIRONMENTAL AUDIT.

(A) SEASIDE/LITTLE shall have the right to cause a Phase I environmental audit of the real property to be conveyed hereunder. And such environmental audit, together with a written declaration from an environmental audit, together with a written declaration from an environmental consultant acceptable to SERVICE, shall reasonably verify that the real property and other facilities to be conveyed hereunder are in compliance with all applicable state and federal environmental laws, and that the facilities and property surrounding the facilities are free of significant environmental hazards/contamination.

SECTION 4.02. SURVEY. Within ten (10) days after entering into this Agreement, SEASIDE/LITTLE shall order a survey of all property being insured by the title insurance policies hereunder. The cost of the survey shall be SEASIDE/LITTLE's expense. The survey shall be (A) received not less than thirty-five (35) days prior to closing and updated thereafter as required by the title insurer; (B) be satisfactory and sufficient to the title insurer to delete the standard exceptions of title insurance coverage concerning encroachments, overlays, boundary line disputes or any other adverse matter which would be disclosed by an accurate survey; (C) be certified as of the current date to SEASIDE/LITTLE, SERVICE, the title insurer or any other parties requested by SEASIDE/LITTLE's counsel; and (D) show the location of all improvements and easements.

SECTION 4.03. TITLE INSURANCE.

(A) Within ten (10) days after entering into this Agreement, SEASIDE/LITTLE shall order a commitment for an ALTA from owner's title insurance policy in the amount of the total purchase price herein. The title insurance commitment shall be delivered to SEASIDE/LITTLE, with a copy to SERVICE, not less than ten (10) days prior to closing. And encumbrances or defects in title must be removed from said commitment prior to closing and the subsequent title insurance policy issued free and clear of encumbrances, title defects or materialman's liens, created or potentially created by SERVICE, with the exception of (a) taxes for the current year

which are not yet due and payable, (b) any permitted title exceptions reflected in the schedule attached hereto as Appendix P, and (c) any encumbrance of or created by SEASIDE/LITTLE, including any instruments evidencing debt executed by SEASIDE/LITTLE at closing.

(B) The insured estate or interests shall consist of all real property identified in Appendix A hereof.

(C) At closing, the owner's title insurance policy shall show marketable title to the insured estate or interests vested in SEASIDE/LITTLE. All charges for the issuance of the owner's title insurance commitment shall be SERVICE's expense.

(D) SEASIDE/LITTLE shall select a title insurer willing to issue the owner's title insurance policy and a Florida Endorsement Form 9 for a premium which shall not exceed the minimum rate promulgated by the Florida Insurance Commissioner. This premium shall be SERVICE's expense.

(E) Marketable title shall be determined according to applicable Title Standards adopted by authority of the Florida Bar and in accordance with law. SEASIDE/LITTLE shall have five (5) days from receiving the title commitment to examine it. If title is found defective, SEASIDE/LITTLE shall thereafter within three (3) days, notify SERVICE in writing specifying the defects. If the defects render the title unmarketable, SERVICE will have sixty (60) days from receipt of notice within which to remove the defects and the closing shall be extended, if necessary, failing which SEASIDE/LITTLE shall have the option of either (1) accepting the title as it then is together with a reduction in the purchase price agreed upon by the parties or (2) canceling this Agreement, thereupon SEASIDE/LITTLE and SERVICE shall release one another of all further obligations hereunder. SERVICE shall, if title is found unmarketable, use diligent effort to correct defects in the title within the time provided; however, SERVICE shall not be required to bring any necessary suits in its efforts to correct the defects.

ARTICLE V
CLOSING PROCEDURES

SECTION 5.01. CLOSING DATE AND PLACE.

(A) SERVICE shall furnish at closing a certificate reaffirming SERVICE's representations and warranties hereunder, a non-foreign affidavit, a no-lien affidavit, a "gap" affidavit, the warranty deed, and the bill of sale, all in substantially the form attached hereto as Appendix Q. SERVICE shall also furnish at closing any necessary assignments, estoppel letters and any corrective instruments as well as enter into a transfer, assignment and assumptions agreement, and any other agreement required to complete the transaction.

(B) SEASIDE/LITTLE shall furnish at closing the closing statement, a certificate reaffirming SEASIDE/LITTLE's representations and warranties hereunder and enter into a transfer, assignment and assumption agreement and any other agreement required to complete the transaction.

(C) From time to time after closing, each party shall, upon request of the other, execute, acknowledge and deliver, or shall cause to be executed, acknowledged and delivered, all such further acts, deeds, assignments, transfers or other documentation for (1) confirming or correcting title in the name of SEASIDE/LITTLE or perfecting undisputed possession by SEASIDE/LITTLE of any or all of the Purchased Assets, or (2) otherwise fulfilling the obligations of the parties hereunder.

SECTION 5.02. RECORDING FEES AND DOCUMENTARY TAXES. SERVICE will be responsible for and pay all documentary stamp taxes required by Section 201.01, Florida Statutes, for any deed that relates to the real property conveyed from SERVICE to SEASIDE/LITTLE and any recording fees to record the deed and any other instruments necessary to deliver marketable title to SEASIDE/LITTLE. As evidence of payment, SERVICE shall execute at closing a Florida Department of Revenue Form DR-219.

SECTION 5.03. PROPERTY TAXES. Taxes on the Purchased Assets shall be prorated as of the day of closing and, if necessary, SERVICE shall escrow with the Charlotte County Tax Collector such prorated taxes in accordance with Section 196.295, Florida Statutes.

SECTION 5.04. ACCOUNTS RECEIVABLE.

(A) Ninety percent of service accounts receivable (for which service has already been provided by SERVICE, and which is not past due more than thirty (30) days after service rendered) due SERVICE, and ninety percent (90%) of all unbilled revenue earned for service as of the date of closing, shall be credited to SERVICE at closing. SERVICE shall furnish to SEASIDE/LITTLE, ten (10) days prior to closing, a listing of its accounts receivable and unbilled revenue, by customer and individual accounts. "Accounts receivable" does not include promissory notes.

(B) Credit shall be given to SEASIDE/LITTLE at closing for the liabilities assumed for customer deposits. A listing of customer deposits by customer account and aggregate totals of same shall be furnished to SEASIDE/LITTLE by SERVICE ten (10) days prior to closing.

(C) Closing may occur during the normal billing cycle of SERVICE. Gross revenues for wastewater services rendered but not yet billed shall be estimated based upon the preceding quarter's billings and a proration of such revenue shall be made with a credit to SERVICE at closing for the number of days elapsed in the current billing cycle. Upon credit to SERVICE for unbilled service at closing, SEASIDE/LITTLE shall be entitled to all revenue collected and derived from the utility system and Purchased Assets from that date forward.

SECTION 5.05. CONNECTION CHARGES.

A. Sums held or collected by SERVICE, including cash connection charges or charges due to SERVICE by virtue of developer notes, capital cost recovery charges and tax gross-up amounts, imposed for service which has been provided prior to the date of closing, shall be transferred to SEASIDE/LITTLE therefore, including but not limited to, the notes receivables due SERVICE from Developers and other customers.

(B) Sums held or collected by SERVICE, including cash connection charges or charges due to SERVICE by virtue of developer notes, capital cost recovery charges and tax gross-up amounts, for which SERVICE installed lines abutting the property of each customer who has not

yet connected to the utility system or extended transmission mains available for connection to developer's system when constructed, in which the eventual connection will not create any additional expense to SEASIDE/LITTLE, shall also remain SERVICE's sole and separate property with no claim of SEASIDE/LITTLE therefor.

(C) Sums held or collected by SERVICE including connection charges, capital cost recovery charges and tax gross-up amounts for which off-site lines have not been installed or abut the customer's property, shall be credited to SEASIDE/LITTLE at closing.

SECTION 5.06. PROFESSIONAL FEES; COSTS. Each party shall be responsible for securing its own counsel for representation during the negotiation and closing of this Agreement; unless otherwise specified herein, and each party shall be responsible for the payment of the fees of its own attorneys, bankers, engineers, accountants and other professional advisors or consultants in connection therewith.

SECTION 5.07. RISK OF LOSS. At all times prior to and through the day of closing, SERVICE shall maintain adequate fire and extended insurance coverage for the cost of any repairs to the Purchased Assets that may be required by casualty damage. The risk of loss during the said period of time shall fall upon SERVICE. The risk of loss shall pass to SEASIDE/LITTLE at closing.

SECTION 5.08. PROCEEDS OF SALE; CLOSING PROCEDURE.

(A) SERVICE shall provide the following documents effecting the transfer of the Purchased Assets to SEASIDE/LITTLE's counsel at least ten (10) days prior to closing; however, these documents shall be executed and delivered at closing:

(1) Warranty deed, with full warranties of title, for the conveyance of all real property to be conveyed hereunder;

(2) Conveyance instruments for all easements;

(3) A transfer, assignment and assumption agreement covering all other interests in the Purchased Assets, together with a general assignment of all contracts, agreements, permits and approvals as provided for herein;

(4) Bill of Sale or other documents of assignments and transfer, with full warranties of title, to all Purchased Assets;

(5) Any affidavits, certificates, estoppel certificates or corrective instrument necessary to close; and

(6) A list of all original permits, governmental authorizations and approvals to be delivered at closing.

ARTICLE VI GENERAL PROVISIONS

SECTION 6.01. INDUCEMENT FOR SEASIDE/LITTLE TO EXECUTE. At closing all of SEASIDE shareholders and directors shall execute a Joint Action of Shareholders and Directors in substantially the form attached hereto as Appendix R.

SECTION 6.02. RIGHT TO ENTER. Prior to closing, SEASIDE/LITTLE's personnel, administrator or consultants shall have the right, at any reasonable time, upon prior notice, to enter upon SERVICE's property to inspect the wastewater system and the Purchased Assets, to familiarize itself with day-to-day operations, to review the operational practices of SERVICE and to ensure compliance with any and all federal and state regulatory requirements.

SECTION 6.03. EMPLOYMENT PREFERENCE. To the extent that SEASIDE/LITTLE may lawfully do so and to the extent that SEASIDE/LITTLE has any position available, SEASIDE/LITTLE will use its best efforts to grant a preference in hiring to any non-management employment qualification and pre-employment screening criteria. All employment resulting from this Section shall be at will.

SECTION 6.04. CONDUCT BETWEEN EXECUTION AND CLOSING.

(A) Upon the execution of this Agreement, SERVICE shall continue to provide service to its current customers in the ordinary and usual manner.

(B) SERVICE shall prudently maintain the system to ensure its proper operation until conveyance.

(C) From and after the date of the execution of this Agreement, SERVICE shall not, without prior written consent of this Agreement, SERVICE shall not, without prior written consent of SEASIDE/LITTLE, dispose of or encumber any of the Purchased Assets, except any transactions that occur in the ordinary course of SERVICE's business.

(D) From and after the date of the execution of this Agreement, SERVICE shall not, without prior written consent of SEASIDE/LITTLE, enter into or modify (1) any agreements, or; (2) enter into or modify any developer or service agreement. Notwithstanding anything to the contrary set forth herein, SERVICE need not obtain SEASIDE/LITTLE's approval to enter developer or service agreements that (a) individually do not commit capacity in excess of one (1) equivalent residential connections or (b) in the aggregate do not commit capacity in excess of five (5) equivalent residential connections.

SECTION 6.05. TIME IS OF THE ESSENCE. Time is of the essence in this Agreement. Time periods specified in this Agreement shall expire at midnight on the date stated unless the parties agree in writing to a different date or time. Any time period provided for herein which ends on Saturday, Sunday or a legal holiday shall extend to 5:00PM on the next business day.

SECTION 6.06. APPLICABLE LAW; JURISDICTION AND VENUE.

(A) This Agreement shall be governed by and construed in accordance with the laws of the State of Florida.

(B) The parties to this Agreement expressly consent to the jurisdiction of and agree to suit in any court of general jurisdiction in the State of Florida, whether state, local or federal, and further agree that venue shall lie in Charlotte County, Florida.

SECTION 6.07. FAILURE OF PERFORMANCE.

(A) A breach of this Agreement shall mean a material failure to comply with any of the provisions of this Agreement. If any party breaches any obligations herein, then, upon receipt of written notice by the non-breaching party, the breaching party shall proceed diligently and in good

faith to take all reasonable actions to cure such breach and shall continue to take all such actions until such breach is cured.

(B) If, for any reason other than the failure of SERVICE to make title to the real property to be conveyed hereunder marketable after diligent effort, SERVICE fail, neglect or refuse to perform this Agreement, SEASIDE/LITTLE may seek specific performance without thereby waiving any action for damages resulting from SERVICE's breach.

(C) If either party breaches this agreement, the injured party may seek damages or specific performance to the extent allowed by law, however, neither party waives its rights privileges or immunities.

SECTION 6.08. NOTICE.

(A) All notice, certificates or other communications hereunder shall be sufficiently given and shall be deemed given when hand delivered or mailed by registered or certified mail, postage prepaid, to the parties at the following addresses:

To SEASIDE/LITTLE : Jack Boyer
 7092 Placida Road
 Cape Haze, Florida

To SERVICE: Jack Boyer
 7092 Placida Road
 Cape Haze, Florida

(B) Any written notice given to one person in subsection (A) of this Section shall also be copied and provided to all other persons identified in subsection (A).

(C) The parties may, by notice in writing given to the others, designate any future or different addresses to which the subsequent notices, certificates or other communications shall be sent. Any notice shall be deemed given on the date such notice is delivered by hand or by facsimile transmission or five (5) days after the date mailed.

SECTION 6.09. ASSIGNMENT. SERVICE shall have the power or authority to assign this Agreement or any part hereof at or prior to closing in anticipation of dissolution or winding up of the affairs of the corporation, however, this agreement shall be binding upon all assigns.

SECTION 6.10. AMENDMENTS AND WAIVERS. No amendment, supplement, modification or waiver of this Agreement shall be binding unless executed in writing by all parties hereto. No waiver of any of the provisions of this Agreement shall be deemed or shall constitute a waiver of any other provision of this Agreement, whether or not similar, unless otherwise expressly provided.

SECTION 6.11 TERMS READ IN CONCERT WITH AGREEMENT. It is agreed by and between the parties hereto that all words, terms and conditions herein contained as to be read in concert, each with the other, and that a provision contained under one heading may be considered to be equally applicable under another heading (including the Appendices) in the interpretation of this Agreement.

SECTION 6.12 AGREEMENT TO BENEFIT ONLY PARTIES HERETO. This Agreement is solely for the benefit of the parties hereto and no other causes of action shall accrue upon, or by reason hereof, be to or for the benefit of any third party, who or which is not a formal party hereto.

SECTION 6.13 EXECUTION OF ADDITIONAL DOCUMENTS. Each party will, at any time and from time to time, after the closing hereof, upon reasonable request to the other party, execute, acknowledge and deliver or will cause to be executed, acknowledged and delivered all such further acts, deeds, assignments, transfers, powers of attorney and assurances, as may be required in order to implement and perform any of the obligations, covenants, and agreements of the parties hereto. Good faith is a specific condition of this Agreement.

SECTION 6.14. ENTIRE AGREEMENT. This Agreement is the entire agreement between the parties pertaining to the subject matter hereof, and supersedes all prior and

contemporaneous agreements, understandings, negotiations and discussions of the agreements, understandings, negotiations and discussions of the parties, whether oral or written, and there are not warranties, representations or other agreements between the parties in connection with the subject matter hereof, except as specifically set forth herein. Upon execution by all parties, SEASIDE/LITTLE shall provide SERVICE three (3) complete certified copies of this Agreement, together with copies of all appendices hereto.

IN WITNESS WHEREOF, SERVICE and SEASIDE/LITTLE have caused this Agreement to be duly executed and entered into on the date first above written.

(SEAL)

SEASIDE SERVICE SYSTEM, INC.

ATTEST:

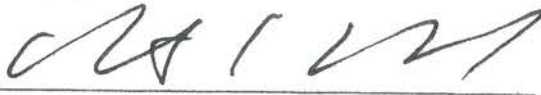

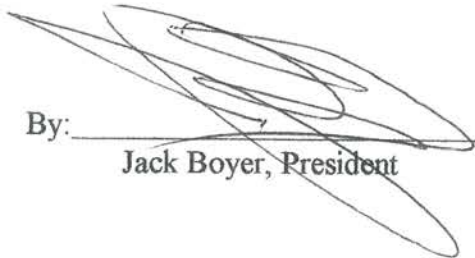
Secretary

By: 
Jack Boyer, President

(SEAL)

SEASIDE/LITTLE GASPARILLA UTILITY, INC.

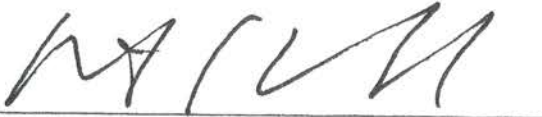
ATTEST:

Secretary

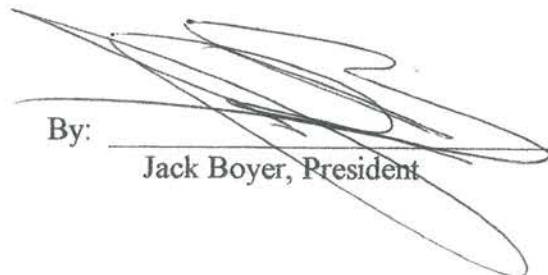
By: 
Jack Boyer, President

THIS INSTRUMENT PREPARED
BY AND TO BE RETURNED TO:

Carl A. Bertoch, P.A.
537 East Park Avenue
Tallahassee, FL 32301

REAL ESTATE MORTGAGE AND SECURITY AGREEMENT

Date: As of January 10, 1996

Mortgagor:

SEASIDE/LITTLE GASPARILLA UTILITY, INC.
P.O. BOX 5145
GROVE CITY, FLORIDA 34224

Mortgagee:

SEASIDE SERVICE SYSTEM, INC. (Or assigns)
and
CAPE HART COMPANY
537 East Park Avenue
Tallahassee, Florida 32301

Amount of initial indebtedness secured hereby:

SEASIDE SERVICE SYSTEM, INC.	\$775,000
CAPE HART COMPANY	25,000
CAPE HART COMPANY	<u>100,000</u>
	\$900,000

Maximum principal indebtedness, including future advances,
that may be secured hereby:

\$900,000

Mortgaged property located in Charlotte County, Florida:

See attached Exhibit "A"

1. MORTGAGE. In consideration of ten dollars and other valuable considerations received by Mortgagor (named above), Mortgagor hereby, on the date stated

above, mortgages to Mortgagee (named above) the mortgaged property described herein, for the purposes identified below.

2. SECURED INDEBTEDNESS; FUTURE ADVANCES; MAXIMUM AMOUNT AND TIME. This mortgage shall secure (a) the indebtedness of Mortgagor to Mortgagees, as evidenced by three Mortgage Notes of even date herewith, executed by Mortgagor and payable to Mortgagee, in the amount specified on page one hereof, and (b) any future advances made by Mortgagee to Mortgagor. The total amount of indebtedness secured hereby may decrease or increase from time to time, but the total unpaid balance so secured at any one time shall not exceed the maximum principal amount specified on page one hereof, plus interest thereon, and any disbursements made for the payment of taxes, levies, or insurance on the mortgaged property, and for maintenance, repair, protection, and preservation of the mortgaged property, with interest on such disbursements, all as provided in this mortgage. This mortgage shall not secure any future advances made more than twenty years from the date hereof.

3. PAYMENT OF SECURED INDEBTEDNESS. Mortgagor shall pay all indebtedness and perform all obligations secured hereby promptly when due.

4. TITLE COVENANTS. Mortgagor covenants that the mortgaged property is free from all encumbrances (other than this mortgage and that certain first mortgage in favor of Peninsula State Bank, dated December 14, 1995 and recorded December 20, 1995 in Official Records Book 1438, Page 1050 of the Public Records of Charlotte County, Florida in the original principal amount of ~~\$140,000.00~~) except as may be specifically stated herein, that lawful seisin of and good right to encumber the mortgaged property are vested in Mortgagor, and that Mortgagor hereby fully warrants the title to the mortgaged property, and warrants to Mortgagee that this Mortgage is and shall be a second mortgage and will defend the same against the lawful claims of all persons whomsoever.

5. IMPROVEMENTS, FIXTURES, ETC. This mortgage extends to and shall encumber all buildings, improvements, fixtures or appurtenances now or hereafter erected or existing upon the mortgaged property, including all elevators and all gas, steam, electric, water, cooking, refrigerating, lighting, plumbing, heating, air conditioning, ventilation, and power systems, machines, appliances, fixtures, and appurtenances, even though they be detached or detachable, all of which shall be deemed part of the mortgaged property.

6. MAINTENANCE AND REPAIR. Mortgagor shall permit, commit, or suffer no waste, impairment, or deterioration of the mortgaged property. Mortgagor shall maintain the mortgaged property in good condition and repair. If Mortgagor fails to do so, then Mortgagee, without waiving the option to foreclose, may take some or all measures that Mortgagee reasonably deems necessary or desirable for the maintenance, repair, preservation, or protection of the mortgaged property, and any expenses reasonably incurred by Mortgagee in so doing shall become part of the indebtedness secured hereby, shall become immediately due and payable, and shall bear interest at the highest lawful rate specified in any note evidencing any

indebtedness secured hereby. Mortgagee shall have no obligation to care for and maintain the mortgaged property, or, having taken some measure therefor, to continue the same or take other measures. If this mortgage covers a unit in a condominium or a planned unit development, Mortgagor shall perform all of Mortgagor's obligations under the declarations and covenants creating or governing the condominium or planned unit development, the by-laws and regulations of the condominium or planned unit development and constituent documents.

7. HAZARD INSURANCE. If any buildings now or hereafter constitute part of the mortgaged property, Mortgagor shall keep the same insured against loss or damage by fire, lightning, windstorm, and other perils customarily insured against or as may be reasonably required by Mortgagee in the full insurable value thereof (or such lesser amount as Mortgagee may authorize in writing), with an insurer of high financial reputation and to which Mortgagee has no reasonable objection. The policy or policies of insurance shall contain a standard mortgagee clause in favor of Mortgagee and shall be delivered to Mortgagee. Mortgagor shall pay all premiums and charges for the maintenance and renewal of the insurance, and shall furnish Mortgagee with receipts and proofs thereof not less than ten days before the expiration thereof, without notice or demand from Mortgagee. If Mortgagor fails to do so, then Mortgagee, without waiving the option to foreclose, may obtain such insurance for the protection of Mortgagee, and any expenses reasonably incurred by Mortgagee in so doing shall become part of the indebtedness secured hereby, shall become immediately due and payable, and shall bear interest at the highest lawful rate specified in any note evidencing any indebtedness secured hereby. In the event of loss, the insurance proceeds shall be applied by Mortgagee to the reduction of the indebtedness secured hereby, or to the restoration and repair of the mortgaged property, at the option of Mortgagee. In the event of foreclosure of this mortgage or transfer of the mortgaged property in full or partial satisfaction of the indebtedness secured hereby, all interest of Mortgagor in the policy or policies of insurance (including any claim to proceeds attributable to losses theretofore occurring but not yet paid to Mortgagor) shall pass to the purchaser, grantee, or transferee.

8. RENTS AND PROFITS. This mortgage shall extend to and encumber all rents, issues, profits, proceeds, and revenues derived from the mortgaged property, but Mortgagor may receive the same while this mortgage is not in default.

9. RECEIVER. If this mortgage falls into default, Mortgagee shall be entitled to the appointment of a receiver to take charge of the mortgaged property, and the rents, issues, profits, proceeds, and revenues arising therefrom, and hold the same subject to the direction of a court of competent jurisdiction, regardless of the solvency of Mortgagor or the adequacy of the security. Furthermore, at its option, Mortgagee shall be authorized and entitled to direct all tenants of the mortgaged property to make any and all payments due under their leases directly to Mortgagee.

10. TAXES, ASSESSMENTS, AND LIENS. Mortgagor shall pay all taxes, assessments, liens, and other charges upon or with respect to the mortgaged property before the same become delinquent, and shall furnish Mortgagee with receipts and proofs thereof at least ten days before the last day allowed for payment free from penalty, without notice or demand

from Mortgagee. If Mortgagor fails to do so, then Mortgagee, without waiving the option to foreclose, may pay the same, and the amount so paid shall become part of the indebtedness secured hereby, shall become immediately due and payable, and shall bear interest at the highest lawful rate specified in any note evidencing any indebtedness secured hereby. In addition, if the ad valorem taxes attributable to the mortgaged property should become delinquent at any time during the term of this Mortgage, then Mortgagee shall have the right to demand that Mortgagor pay Mortgagee sufficient funds on demand to establish an escrow fund for the payment of ad valorem taxes and to pay an amount each month to Mortgagee deemed adequate by Mortgagor to maintain such escrow account for the purpose of paying the ad valorem taxes as they come due.

11. INSPECTION. Mortgagee and Mortgagee's representatives may enter upon the mortgaged property for inspection at all reasonable times and in a reasonable manner, both before and after default.

12. EMINENT DOMAIN. This mortgage extends to and shall encumber any judgments, awards, damages, and settlements hereafter rendered or paid and resulting from condemnation proceedings with respect to the mortgaged property or the taking of the mortgaged property or any part thereof under the power of eminent domain, and Mortgagee may require that any sums payable to Mortgagor and arising out of the power of eminent domain with respect to the property shall be applied to the indebtedness secured hereby.

13. ENFORCEMENT AND COLLECTION EXPENSES. Mortgagor shall pay all expenses, including attorney's fees, reasonably incurred by Mortgagee with respect to collection of the indebtedness secured hereby or enforcement of Mortgagee's rights hereunder (including foreclosure, bankruptcy, appeals or other litigation expenses), arising out of any default by Mortgagor, and the amount thereof shall become part of the indebtedness secured hereby, shall become immediately due and payable, and shall bear interest at the highest lawful rate specified in any note evidencing any indebtedness secured hereby.

14. ACCELERATION UPON DEFAULT. If Mortgagor, or any other obligor, or guarantor under the Note evidencing the indebtedness secured by this Mortgage fails to pay any indebtedness secured hereby promptly when due (or within such grace period as may be provided in the note or notes evidencing the indebtedness), or if Mortgagor materially breaches any other covenant herein or otherwise materially defaults hereunder or under the Mortgage Note from Mortgagor in favor of Mortgagee, then Mortgagee may declare all indebtedness secured hereby to be accelerated and immediately due and payable. Mortgagee's failure to declare an acceleration shall not impair the right to do so in the event of a continuing or subsequent breach or default. Upon any such default of this Mortgage, Mortgagee may foreclose this Mortgage and take any other actions permitted by this Mortgage or permitted by law.

15. ACCELERATION UPON TRANSFER OF MORTGAGED PROPERTY.
As a material inducement to Mortgagee making the loan to Mortgagor, Mortgagor agrees that if Mortgagor sells or transfers the mortgaged property, then Mortgagee may declare all indebtedness secured hereby to be accelerated and immediately due and payable, unless Mortgagee consents in writing to the sale or transfer. Mortgagee shall not unreasonably withhold

his consent to a transfer of the mortgaged property if such transfer is pursuant to a bona fide sale to an unrelated third party for fair market value for cash or on other terms.

16. NO WAIVER. No delay by Mortgagee in exercising any option, right, or remedy hereunder or otherwise afforded by law shall waive or preclude the exercise thereof during the continuance of any breach or default hereunder. No waiver by Mortgagee of any provision, breach or default shall be a waiver of any other provision or a consent to any subsequent breach or default.

17. DEFAULT UNDER OTHER MORTGAGES, CROSS DEFAULT. If the mortgaged property or any part thereof is now or hereafter encumbered by any other mortgage, then any default under any of such other mortgages shall also be a default hereunder. Also, any default in any note, mortgage, security agreement or other agreement, in favor of Mortgagee by Mortgagor, shall, at the option of Mortgagee, also constitute a default hereunder.

18. EXTENSION, LENIENCIES, AND RELEASES. Mortgagee may grant extensions of time for payment and other leniencies with respect to any indebtedness secured hereby, and may waive or fail to enforce any of Mortgagee's rights hereunder, and may release a portion or portions of the mortgaged property from the lien hereof, without releasing or diminishing the obligation or liability of any person constituting Mortgagor, or any guarantor or endorser.

19. SUBROGATION. Mortgagee shall be surrogated to the lien (notwithstanding its release of record) of any vendor, mortgagee, or other lienholder paid or discharged by the proceeds of any loan or advance made by Mortgagee to Mortgagor and secured hereby.

20. RELEASE OR SATISFACTION. Whenever there is no outstanding obligation secured hereby and no commitment to make advances, Mortgagee shall on written demand by Mortgagor give a release hereof, in recordable form.

21. WAIVER OF TRIAL BY JURY. Mortgagor and Mortgagee (by its acceptance hereof) hereby knowingly, voluntarily and intentionally waive the right they may have to a trial by jury in respect of any litigation based hereon, or arising out of, under, or in conjunction or connection with this mortgage, the indebtedness secured hereby and any other document contemplated to be executed in conjunction with the loan or loan secured hereby, or any course of conduct, course of dealing, statements (whether verbal or written), or actions of either party. This provision is a material inducement for Mortgagee to enter into any loan transaction secured hereby.

22. HAZARDOUS SUBSTANCES. In addition to any liability imposed on the Mortgagor under any other document executed in conjunction with the loan secured hereby, the Mortgagor shall remain liable for and shall reimburse Mortgagee on demand for any and all of Mortgagee's costs, expenses, damages or liabilities, and shall indemnify and hold Mortgagee harmless from any such damage or liability arising directly or indirectly or attributable to the use, generation, storage, release, threatened release, discharge, disposal or existence for any reason of

hazardous substances on or in the mortgaged property or in the water on, in or under the mortgaged property. This liability of Mortgagor shall survive satisfaction of the debt from Mortgagor to Mortgagee.

23. MORTGAGE AS SECURITY AGREEMENT. This Mortgage is a mortgage of both real property and any improvements and fixtures thereon, equipment and articles of personal property now or hereafter affixed and used in connection with the operation of the premises and shall also serve as a "security agreement" within the meaning of the Uniform Commercial Code as adopted by the State of Florida and the Mortgagor agrees to and shall execute and deliver to Mortgagee in form satisfactory to Mortgagee such Financing Statements and such further assurances as Mortgagee may from time to time consider necessary to create, perfect and preserve the lien hereof upon such real property and improvements and such fixtures, equipment and articles of personal property herein described and intended to be subject hereto and the Mortgagee at the expense of Mortgagor, may or shall cause such statements and assurances and the Mortgage and Security Agreement to be recorded and re-recorded, filed and re-filed at such times and places as may be required or permitted by law to so create, protect and preserve the lien hereof upon all of said property; it being understood and agreed that this covenant and any agreements or instruments executed hereunder are cumulative and given as additional security.

24. NO AGENCY. Mortgagor covenants and agrees that Mortgagee is not a partner, joint venturer or principal of Mortgagor and Mortgagor is not an agent of Mortgagee. Mortgagee agrees to indemnify and hold Mortgagee harmless from and all damages, expenses or otherwise resulting from such construction of the parties and their relationship.

25. NO JUNIOR LIENORS. In the event that a lien or encumbrance, such as a mechanics or construction lien, is filed encumbering the mortgaged property, then Mortgagor shall be deemed to be in default of this Mortgage unless Mortgagor causes such lien or encumbrance to be removed within 30 days after such lien is filed.

26. GENERAL PROVISIONS. The singular shall include the plural and any gender shall be applicable to all genders when the context permits or implies. If more than one person constitutes Mortgagor, their covenants and obligations hereunder shall be joint and several. If Mortgagor sells or transfers the mortgaged property, Mortgagee may deal with the successor or successors in interest without in any way discharging or reducing Mortgagor's liability for Mortgagor's obligations secured hereby. Mortgagee's rights expressed herein are in addition to and cumulative of any other rights and remedies provided by law. The terms "Mortgagor" and "Mortgagee" shall extend to and include their respective heirs, legal representatives, successors and assigns. Any agreement hereafter made by Mortgagor and Mortgagee pursuant to this mortgage shall be superior to the rights of the holder of any intervening lien or encumbrance. Time is of the essence.

IN WITNESS WHEREOF, Mortgagor has executed this mortgage as of the date first stated above.

Signed in the presence of:

Seaside/Little Gasparilla Utility, Inc.

Sign: [Handwritten Signature]
Print: ROBERT L. UNDERWOOD

By: [Handwritten Signature]
Jack Boyer
Its: President

Sign: Sylvia Wallace
Print: Sylvia Wallace
Two witnesses

STATE OF FLORIDA)
):ss
COUNTY OF CHARLOTTE)

The foregoing instrument was acknowledged before me this 13th day of January, 1996, by Jack Boyer, President of Seaside/ Little Gasparilla Utility, Inc., who is personally known to me and executed the foregoing instrument on behalf of the corporation.

Sharon L. Waldee
Signature
Sharon L. Waldee
Type or Print Name

(NOTARY SEAL)
Commission Expires:

NOTARY PUBLIC, STATE OF _____
Commission Number _____

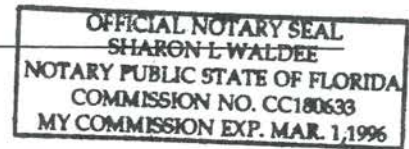

**SEASIDE SERVICE SYSTEM, INC.
WRITTEN CONSENT OF THE BOARD OF DIRECTORS
TO ACTION WITHOUT A MEETING**

The undersigned, being all of the Directors of Seaside Service System, Inc., a Florida corporation, do hereby waive any and all requirements for the holding of a meeting of the Board of Directors of the Corporation and do hereby take the following actions and adopt the following preambles and resolutions by signing our written consent hereto pursuant to the provisions of the Florida Business Corporation Act:

RESOLVED:

1. That the Board of Directors of the Corporation finds it in the best interest of the Corporation that the Corporation authorize the sale of the utility system, for the amount of \$1,000,000 (one million dollars), subject to a mortgage obligation of \$150,000 (one hundred fifty thousand dollars) to Peninsula Bank, pursuant to the attached transfer documents.

2. That the Board of Directors of the Corporation authorizes the Officers of the Corporation to execute all documents relating to the sale of the system to Seaside/Little Gasparilla Utility, Inc.

3. That all actions by the Officers of this Corporation in regard to the negotiation of the above transaction be and they hereby are ratified, approved and confirmed in all respects.

We hereby consent that this document be filed with the minutes of the Corporation and that the actions set forth in the foregoing preamble and resolution shall have the same force and effect as if taken at a duly constituted meeting of the Board of Directors of the Corporation.

WITNESS our hands and seals as of the 30th day of June, 1995.

DIRECTORS:



State of Florida



Department of State

I certify the attached is a true and correct copy of the Articles of Merger, filed on January 18, 1996, for LITTLE GASPARILLA UTILITY, INC., the surviving Florida corporation, as shown by the records of this office.

The document number of this corporation is N96000000196.

Given under my hand and the
Great Seal of the State of Florida,
at Tallahassee, the Capitol, this the
Eighteenth day of January, 1996



CR2EO22 (2-95)

Sandra B. Mortham

Sandra B. Mortham
Secretary of State

96 JAN 18 AM 10:35
FILED
SECRETARY OF STATE
TALLAHASSEE, FLORIDA

ARTICLES OF MERGER

Pursuant to the provisions of Section 617.051, F.S. and Section 607.1105, F.S., the undersigned Florida corporations have adopted Articles of Merger for the purpose of merging them into one such corporation:

1. The Plan of Merger was approved by each of the undersigned corporations, a copy of which is attached hereto as Exhibit "A" and incorporated herein by reference.
2. As to each of the undersigned corporations, the Plan of Merger was adopted in the following manner:
 - (a) The Plan of Merger was adopted by **SEASIDE/LITTLE GASPARILLA UTILITY, INC.** by unanimous written consent of the Directors and Shareholders on January 12, 1996.
 - (b) The Plan of Merger was adopted by **LITTLE GASPARILLA UTILITY, INC.** by the Directors on January 12, 1996. There are no members entitled to vote as stated in Article XII of the Articles of Incorporation.
3. The name of the surviving corporation is **LITTLE GASPARILLA UTILITY, INC.**, a Florida Not-for-Profit corporation.
4. The manner of the adoption of the Plan of Merger and the vote by which it was adopted constitute full legal compliance with the provisions of Section 617.051, F.S. and Section 607.1103 F.S. and with the Articles of Incorporation and By-Laws of the undersigned corporations.
5. The effective date of the merger is the date on which the Certificate of Merger is issued by the Florida Department of State.

DATED: 1/12/96

**SEASIDE/LITTLE GASPARILLA
UTILITY, INC.**

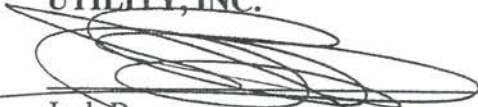

Jack Boyer
President/Director

LITTLE GASPARILLA UTILITY, INC.

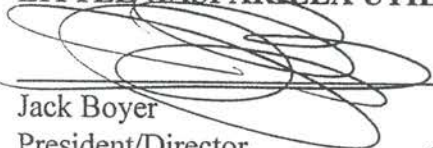

Jack Boyer
President/Director



Robert L. Underwood
Secretary/Director

MERGER AGREEMENT

Agreement made this 12th day of January, 1996, between **SEASIDE/LITTLE GASPARILLA UTILITY, INC.**, a corporation organized under the laws of the State of Florida, having its principal office at Palm Island, Cape Haze, Florida, and **LITTLE GASPARILLA UTILITY, INC.**, a Not-for-Profit corporation organized under the laws of the State of Florida, having its principal office and place of business at Little Gasparilla Island, Cape Haze, Florida.

RECITALS

The respective Directors and Shareholders of the respective corporations deem it desirable and in the best interest of the corporations and their shareholders/members that **SEASIDE/LITTLE GASPARILLA UTILITY, INC.** be merged into **LITTLE GASPARILLA UTILITY, INC.**

For reasons set forth above, and in consideration of the mutual covenants and promises of the parties hereto, the constituent corporations agree, pursuant to Sections 607.1101, 607.1103, 607.1105, and 607.1106 and Section 617.051, Florida Statutes, that **SEASIDE/LITTLE GASPARILLA UTILITY, INC.** shall be merged into **LITTLE GASPARILLA UTILITY, INC.** as a single corporation; and the parties agree to and prescribe the terms and conditions of such merger and the method of carrying it into effect.

SECTION ONE LITTLE GASPARILLA UTILITY, INC. TO BE SURVIVING CORPORATION

SEASIDE/LITTLE GASPARILLA UTILITY, INC. shall be merged into **LITTLE GASPARILLA UTILITY, INC.** and the corporate existence of **SEASIDE/LITTLE GASPARILLA UTILITY, INC.** shall cease and the corporate existence of **LITTLE GASPARILLA UTILITY, INC.** shall continue under the name of **LITTLE GASPARILLA UTILITY, INC.**, which shall become the owner, without other transfer, of all the rights and property of the constituent corporations, and **LITTLE GASPARILLA UTILITY, INC.** shall

FILED
96 JAN 18 AM 10:35
SECRETARY OF STATE
TALLAHASSEE, FLORIDA

STATE OF FLORIDA _____)
)ss
COUNTY OF CHARLOTTE)

I HEREBY CERTIFY that on this day before me, an officer duly qualified to take acknowledgments, personally appeared Jack Boyer, President/Director of Seaside Little Gasparilla, Inc. who is personally known to me ~~or who has produced _____~~ as identification and executed the foregoing instrument and acknowledged before me that he executed the same on behalf of the corporation.

WITNESS my hand and official seal in the County and State last aforesaid this 12th day of January, 1996.

Era Lucille Fountain
Notary Public

Era Lucille Fountain
(Print or Type Name)

Commission Number: CC179103

STATE OF FLORIDA _____)
)ss
COUNTY OF CHARLOTTE)

I HEREBY CERTIFY that on this day before me, an officer duly qualified to take acknowledgments, personally appeared Jack Boyer, President/Director and Robert L. Underwood, Secretary/Director of Little Gasparilla Utility, Inc., who is personally known to me ~~or who has produced _____~~ as identification and executed the foregoing instrument and acknowledged before me that he executed the same on behalf of the corporation.

WITNESS my hand and official seal in the County and State last aforesaid this 12th day of January, 1996.



Era Lucille Fountain
Notary Public

Era Lucille Fountain
(Print or Type Name)

Commission Number: CC179103

become the subject to all the debts and liabilities of the constituent corporations in the same manner as if **LITTLE GASPARILLA UTILITY, INC.** had itself incurred them.

**SECTION TWO
PRINCIPAL OFFICE**

The principal office of **LITTLE GASPARILLA UTILITY, INC.** shall remain the principal office of the corporation following this merger.

**SECTION THREE
OBJECTS AND PURPOSES**

The nature of the business and purposes proposed to be transacted and carried on by the corporation following the merger remain the same as prior to the merger, as provided in Chapter 617, Florida Statutes.

**SECTION FOUR
ARTICLES OF INCORPORATION**

The Articles of Incorporation of **LITTLE GASPARILLA UTILITY, INC.** shall not be amended and shall continue to be the Articles of Incorporation of the surviving corporation.

**SECTION FIVE
BY-LAWS**

The present By-Laws of **LITTLE GASPARILLA UTILITY, INC.** insofar as not inconsistent with this Agreement of Merger, shall be the By-Laws of the corporation following the merger until altered, amended, or repealed as therein provided.

LITTLE GASPARILLA UTILITY, INC.
Little Gasparilla, Florida

TO: Customers of Little Gasparilla Utility, Inc. (formerly Seaside Service Systems, Inc.)
FROM: Jack Boyer
DATE: April 3, 1996
RE: Status of Utility

As you all know, I have been working over the last year to seek a way to balance the many demands of our utility system-service, expansion, source of emergency water supply, DEP regulations, PSC regulations, and the long term financial well-being of the system. The use of a Water Authority has been discussed with you in several meetings.

With a view toward service, we recently expanded our capacity from 18,000 to 36,000 gallons per day. This should alleviate the problems of demand that we have had from time to time. In addition, we are in the process of an interconnect with Rotonda Utility Corporation that would provide water in the case of emergency.

In an ongoing effort to accomplish all of our objectives for the system, we formed a Florida Not-for-Profit corporation, Little Gasparilla Utility, on January 11, 1996 which will own the utility system. The corporation will operate as a Member owned and operated cooperative. It will be tax exempt for federal tax purposes as a Section 501(c)(12) organization.

The status as a member organization will allow the utility to be exempt from PSC regulations since it is under the control of the members. This exemption has been approved by the Public Service Commission. This will save the utility substantial amounts of money by not being subject to the annual filing and rate

making rules of the PSC. The PSC regulates rate setting only and has nothing to do with the quality of the water.

The utility will continue to be licensed and regulated by the DEP. Therefore, the quality of our system will be subject to the same rules with which we have always complied.

The new corporation mentioned above acquired the utility by means of a merger of the old Seaside System's corporate entity into the new Not-for-Profit organization. The assets and liabilities of the old system merely became part of Little Gasparilla Utility by means of the merger. However, no Seaside customer who is now a Member and customer of Little Gasparilla Utility, has become obligated for anything with the utility. As customers/Members of the new corporation, each will have a right to vote for Directors, etc. The customers have not assumed any liabilities of the utility. The customers will continue to pay a fair rate for water which will be set by the Board of Directors (elected by the members), not the PSC.

The first member meeting is scheduled for this summer and at that meeting a Board of Directors will be elected to manage the organization.

If you have further questions, please feel free to contact me.

3A

LITTLE GASPARILLA WATER UTILITY, INC.

P.O. BOX 5159

GROVE CITY, FLORIDA 34224

941-681-2778

January, 2014

Letter of Understanding between Little Gasparilla Water Utility Inc. and Marc Alan Essig in Reference to ownership of a 2009/PLC, 22' Prolite Boat. Hin # PLCLC001E809

I Marc Essig understands this boat, ownership and liability is fully that of Little Gasparilla Water Utility Inc. They have provide all funding as well as insurance payments.

Marc Essig



Date 1/27/14

Erickson M (cont) \$2100

#3

Boat

PRO LINE



SALES AGREEMENT

7891 N. Tamiami Trail ~ Sarasota, FL 34243
Phone 941-365-4444 ~ Fax 941-351-7893

Delivery Date: December 31, 2010

Buyer's Name: MARC ESSIG
Home Address: 4201 Rose Arbor
City: Port Charlotte St. FL
Phone 941-286-6350 email
Date: December 31, 2010
Zip: 33948

(hereinafter called BUYER), and the Buyer agrees to purchase from Erickson Marine Corp. the following described property to be delivered to and accepted by BUYER F.O.B. Englewood, Florida on or before December 8, 2010. (hereinafter called Delivery Date) or, as provided below in cases of late delivery from the manufacturer within 10 days after the Buyer has been notified that Erickson Marine Corp. has received such property from the manufacturer.

Table with columns: SERIAL NO., DESCRIPTION, PRICE. Includes rows for Boat, Motor, Drive, Trailer, Accessories, Options, Trade-in, and various fees.

Payments: Months @ Per Month To Chart

This agreement shall not be binding on Erickson Marine Corp. unless it is signed by an officer of Erickson Marine Corp. No other person is authorized to sign this contract on behalf on Erickson Marine Corp. Approved: Erickson Marine Corp.

By: [Signature] Officer
[Signature] Buyers Signature

RETAIL INSTALLMENT CONTRACT AND SECURITY AGREEMENT No. _____ Date _____	Seller _____ _____ _____ _____	Buyer _____ _____ _____ _____
	"We" and "us" mean the Seller above, its successors and assigns. "You" and "your" mean each Buyer above, and each guarantor, jointly and individually.	

SALE: You agree to purchase from us, on a time basis, subject to the terms and conditions of this contract and security agreement (Contract), the goods (Goods) and services described below. The Goods are sold in their present condition, together with the usual accessories and attachments.

Description of Goods or Services Purchased	Serial or Unit No.	Motor or Cabinet No.	Price of Each Unit
_____	_____	_____	_____

Description of Other Collateral (Not household goods) _____

SECURITY: To secure your payment and performance under the terms of this Contract, you give us a security interest in the Goods purchased and any other collateral described above, and all accessions, attachments, accessories, and equipment placed in or on the Goods or other collateral, together called Property, and proceeds of the Property. You also assign to us and give us a security interest in proceeds and premium refunds of any insurance and service contracts purchased with this Contract.

PROMISE TO PAY AND PAYMENT TERMS: You promise to pay us the principal amount of \$ _____, plus finance charges accruing on the unpaid balance at the rate of _____ % per year from today's date until paid in full. Finance charges accrue on a _____ day basis. You agree to pay this Contract according to the payment schedule and late charge provisions shown in the

TRUTH IN LENDING DISCLOSURES. You also agree to pay any additional amounts according to the terms and conditions of this Contract.

LOAN PROCESSING FEE: You agree to pay a non-refundable loan processing fee of \$ _____ that will be paid in cash. added to the cash price.

DOWN PAYMENT: You also agree to pay, or apply to the Cash Price, on or before today's date, any cash, rebate and net trade-in value described in the ITEMIZATION OF AMOUNT FINANCED. You agree to make deferred payments as part of the cash down payment as reflected in your Payment Schedule.

TRUTH IN LENDING DISCLOSURES

ANNUAL PERCENTAGE RATE	FINANCE CHARGE	AMOUNT FINANCED	TOTAL OF PAYMENTS	TOTAL SALE PRICE
The cost of your credit as a yearly rate. _____ %	The dollar amount the credit will cost you. \$ _____	The amount of credit provided to you or on your behalf. \$ _____	The amount you will have paid when you have made all scheduled payments. \$ _____	The total cost of your purchase on credit, including your down payment of \$ _____

Payment Schedule: Your payment schedule will be

Number of Payments	Amount of Payments	When Payments Are Due
_____	_____	_____

Security: You are giving a security interest in (description of other property) the Goods purchased.

Late Charge: If a payment is more than _____ days late, you will be charged _____.

Prepayment: If you pay off this Contract early, you will not have to pay a penalty.

Contract Provisions: You can see the terms of this Contract for any additional information about nonpayment, default, any required repayment before the scheduled date, and prepayment refunds and penalties.

CREDIT INSURANCE: Credit life, credit disability (accident and health), and any other insurance coverage quoted below, are not required to obtain credit and we will not provide them unless you sign and agree to pay the additional premium. If you want such insurance, we will obtain it for you (if you qualify for coverage). We are quoting below ONLY the coverages you have chosen to purchase.

Credit Life: Insured _____
 Single Joint Prem. \$ _____ Term _____

Credit Disability: Insured _____
 Single Joint Prem. \$ _____ Term _____

Your signature below means you want (only) the insurance coverage(s) quoted above. If none are quoted, you have declined any coverages we offered.

Buyer _____ d/o/b _____ Buyer _____ d/o/b _____

PROPERTY INSURANCE: You must insure the Property securing this Contract. You may purchase or provide the insurance through any insurance company reasonably acceptable to us. The deductible amount of this insurance may not exceed \$ _____.

If you get insurance from or through us you will pay \$ _____ for _____ of coverage.

This premium is calculated as follows:
 Fire-Theft and Combined Additional Coverage \$ _____
 _____ \$ _____
 _____ \$ _____

BODILY INJURY OR PROPERTY DAMAGE LIABILITY NOT INCLUDED UNLESS CHECKED AND INDICATED.

SINGLE-INTEREST INSURANCE: You must purchase single-interest insurance. The coverage may be obtained from a company of your choice, reasonably acceptable to us. If you buy the coverage from or through us, you will pay \$ _____ for _____ of coverage.

This insurance is solely for the interest of the Seller, its successors and assigns, and no protection exists for your benefit.

Signed: _____

ITEMIZATION OF AMOUNT FINANCED

Goods and/or Services Price	\$ _____
(including sales tax of \$ _____)	
Service Contract, Paid to:	\$ _____
Amount to Finance line e. (if e. is negative)	\$ _____
Cash Price	\$ _____
Manufacturer's Rebate	\$ _____
Cash Down Payment	\$ _____
Deferred Down Payment	\$ _____
a. Total Cash/Rebate Down	\$ _____
b. Trade-In Allowance	\$ _____
c. Less: Amount owing	\$ _____
Paid to:	
d. Net Trade-In (b. minus c.)	\$ _____
e. Net Cash/Trade-In (a. plus d.)	\$ _____

Down Payment (e.; disclose as \$0 if negative)	\$ _____
Unpaid Balance of Cash Price	\$ _____
Paid to Public Officials - Filing Fees	\$ _____
Insurance Premiums*	\$ _____
(See adjacent coverage and benefit types.)	
Loan Processing Fee Paid to Seller	\$ _____
To: _____	\$ _____
To: _____	\$ _____
To: _____	\$ _____
Total Other Charges/Amounts Pd. to Others	\$ _____
Less: Prepaid Finance Charges	\$ _____
Amount Financed	\$ _____

*We may retain or receive a portion of this amount.

SERVICE CONTRACT: With your purchase of the Goods, you agree to purchase a Service Contract to cover _____.

_____ This Service Contract will be in effect for _____.

NOTICE TO BUYER

A. Do not sign this agreement before you read it or if it contains any blank spaces. B. You are entitled to an exact copy of the contract you sign. Keep it to protect your legal rights.

BY SIGNING BELOW BUYER AGREES TO THE TERMS ON PAGES 1 AND 2 OF THIS CONTRACT AND ACKNOWLEDGES RECEIPT OF A COPY OF THIS CONTRACT.

Buyer: _____
 Signature _____ Date _____
 Signature _____ Date _____
 Seller: By _____

ASSIGNMENT: This Contract and Security Agreement is assigned to _____, the Assignee, phone _____. This assignment is made under the terms of a separate agreement. under the terms of the ASSIGNMENT BY SELLER on page 2. This assignment is made with recourse.
 Seller: By _____ Date _____

3-C-1
3-B

12/31/13 2013 FEDERAL SUMMARY DEPRECIATION SCHEDULE PAGE 1

CLIENT 047 LITTLE GASPARILLA WATER UTILITY, INC. 65-0824222

4/23/14 08:09PM

NO.	DESCRIPTION	DATE ACQUIRED	DATE SOLD	COST/ BASIS	BUS. PCT.	CUR 179/ SDA	PRIOR 179/ SDA/ DEPR.	METHOD	LIFE	CURRENT DEPR.
FORM 1120S										
AMORTIZATION										
23	LOAN COSTS	1/23/03		478			478	S/L	5	0
24	LOAN COSTS	VARIOUS		1,779			1,779	S/L	5	0
30	LOAN POINTS	3/27/09		491			491	S/L	2	0
35	LOAN COSTS	3/31/11		404			142	S/L	5	81
TOTAL AMORTIZATION				3,152		0	2,890			81
AUTO / TRANSPORT EQUIPMENT										
31	2009 PRO-LINE 22 SE BOAT	12/31/10		20,511			7,713	200DB MQ	10	2,560
34	1993 FORD RANGER	4/18/11		2,350			1,222	200DB HY	5	451
39	1960 BOAT	12/06/13		1,700				200DB MQ	5	85
TOTAL AUTO / TRANSPORT EQUI				24,561		0	8,935			3,096
BUILDINGS										
1	REJECT WALLS	4/01/99		31,291			31,291	S/L HY	10	0
2	REJECT WALLS	4/01/99		31,291			31,291	S/L HY	10	0
3	REJECT WALLS	4/01/99		31,291			31,291	S/L HY	10	0
4	MONITORING WELLS	4/01/99		21,556			21,556	S/L HY	10	0
5	TESTING EQUIPMENT	4/01/99		8,344			8,344	S/L HY	10	0
6	PUMPS	4/01/99		12,171			12,171	S/L HY	10	0
7	TRANSMISSION LINES-2"	4/01/99		76,488			76,488	S/L HY	10	0
8	TRANSMISSION LINES-3"	4/01/99		59,104			59,104	S/L HY	10	0
9	TRANSMISSION LINES-4"	4/01/99		52,151			52,151	S/L HY	10	0
10	OFFICE EQUIPMENT	4/01/99		2,953			2,953	S/L HY	10	0
11	METERS-INSTALLED	4/01/99		17,384			17,384	S/L HY	10	0
12	RO PROCESSING PLANT	4/01/99		205,127			205,127	S/L HY	10	0
13	MAINTENANCE EQUIPMENT	4/01/99		3,477			3,477	S/L HY	10	0
14	STORAGE FACILITY	4/01/99		118,209			118,209	S/L HY	10	0
15	PSC FILINGS	4/01/99		43,632			43,632	S/L HY	10	0
16	BUILDING	4/01/99		52,151			52,151	S/L HY	10	0
17	PERMITS	4/01/99		52,151			52,151	S/L HY	10	0
19	PUMPS	4/01/99		18,000			18,000	S/L HY	10	0
20	2001 STRUCTURE	12/31/01		9,085			3,993	S/L HY	25	363
21	2002 STRUCTURE	12/31/02		7,142			2,896	S/L MQ	25	286
22	2002 PLANT REFURBISHING	12/31/02		105,548			42,748	S/L MQ	25	4,222

#C2

Home Mail News Sports Finance Weather Games Groups Answers Screen Flickr Mobile More

Search Mail Search Web Jack



Compose

Back Forward Delete Move Spam View More Sponsored

- Inbox (3)
- Drafts
- Sent
- Spam (620)
- Trash (7)
- ▼ Folders (17)
 - Accounting
 - appraisals
 - ATT
 - Boat
 - Britt
 - credit
 - Deleted Items (16)
 - e-bay
 - Erin's wedding
 - Farmers Market
 - forms
 - FPL-LGWU
 - HC LLC,
 - Holy Land 2012
 - Insurance
 - Investors
 - Islands
 - KIU
 - Legal
 - LGWU
 - loans
 - Marinas
 - N.C. Property
 - Notes
 - OFF-THE-HOOK
 - O-T-H
 - PAT
 - Pedals Pushers
 - Pictures
 - PSC
 - Rocky Creek
 - Sent Items
 - Synced Messages
 - Taxes (1)
 - Testimonys
 - Wallace
 - YL

<input type="checkbox"/>	Bost...	BU Health Communication Masters D...	Sponsored	
<input type="checkbox"/>	eBay	jack, you have a special offer from eBay	2:25 PM	
<input type="checkbox"/>	Teresa C	boat depreciation	2:03 PM	
<input type="checkbox"/>	süheyta	5 new petition signatures: süheyta calisl	1:57 PM	
<input type="checkbox"/>	Snyder,	RE: LGWU	12:43 PM	

boat depreciation

Teresa Cabe Today at 2:03 PM
To Jack Boyer, Audrey - home, Jack Boyer (lwjd777@yahoo.com)

Audrey,

I looked into the boat and agree with Jack and the PSC that it should be depreciated over 5 years instead of 10. Since the 2013 tax return for LGWU has not yet been e-filed, I can adjust the depreciation to reflect the recalculated depreciation expense for 2013 while also catching up prior years' at the same time

Please note that due to annual depreciation limits on passenger vehicles/listed property, there are caps on the amount of depreciation that is allowed to be taken each year for the property. You will still get to take the full amount of depreciation expense, but it will require longer than 5 years to recoup the total amount. Because of these limitations, the additional depreciation expense to be included in 2013 to catch up prior years is \$378. Going forward, \$1,775 will be expensed each year until the balance is fully depreciated.

Please let me know if you have questions or what further information.

Thank you!
Teresa

Teresa M. Cabe, CPA
Underwood & Roberts, PLLC
919-664-8803
tcabe@rlulaw.com

THIS ELECTRONIC TRANSMISSION, INCLUSIVE OF ATTACHED DOCUMENTS, IS CONFIDENTIAL IF SO MARKED AND MAY CONTAIN ATTORNEY-CLIENT PRIVILEGED INFORMATION. IT IS COVERED BY THE ELECTRONIC COMMUNICATIONS PRIVACY ACT, 18 U.S.C. SECTIONS 2510-2521 AND IS EXPRESSLY INTENDED FOR THE ADDRESSEE ONLY. IF IT HAS BEEN RECEIVED IN ERROR, PLEASE CONTACT UNDERWOOD & ROBERTS, PLLC AS SOON AS POSSIBLE AT (919) 664-8803. FURTHER, PLEASE DELETE THE TRANSMISSION FROM YOUR SYSTEM. THANK YOU FOR YOUR COOPERATION.

IRS Circular 230 Disclosure: To ensure compliance with requirements imposed by the IRS, we inform you that any U.S. Federal tax advice, if any, contained in this document and its attachments may not be used or referred to in the promoting, marketing or recommending of any entity, investment plan or arrangement, nor is such advice intended or written to be used, and may not be used, by a taxpayer for the purpose of avoiding tax penalties under the Internal Revenue Code.

-----Original Message-----

- Stop Paying Credit Card Interest Today**
NextAdvisor.com
- What Is The Most Effective Way To Quit Smoking?**
YourBetterTomorrow
- The 10 Best Stocks to Hold Forever**
StreetAuthority
- Bailout Helps Homeowners Switch to 15 Year Fixed**
LowerMyBills
- New Site Grants Access to Anyone's Public Record**
Instant Checkmate

Sponsored



Match.com
View Singles in Your Area

3d3.

STATE OF FLORIDA
DEPARTMENT OF HIGHWAY SAFETY AND MOTOR VEHICLES - DIVISION OF MOTOR VEHICLES
2900 Apalachee Parkway, NEIL KIRKMAN BUILDING - TALLAHASSEE, FL 32399-0610

Notice of Sale and/or Bill of Sale for a Motor Vehicle,
Mobile Home, Off-Highway Vehicle or Vessel

- Notice of Sale (Seller must complete sections 1 & 3). The purchaser's signature in section 3 is optional.
- Bill of Sale (Seller and purchaser must complete sections 1, 2 (when applicable) & 3).

1. Motor Vehicle, Mobile Home, Off-Highway or Vessel Description

Year 1960	Make/Manufacturer Gaspar	Body Type Fiberglass	Model V-Hull	Color Blue
Certificate of Title Number		Vehicle/Vessel Identification Number		
I/we do hereby sell or have sold and delivered the above described motor vehicle, mobile home, off-highway vehicle or vessel to:				
Print Name(s) of Purchaser(s) Little Gasparilla Water Works				
Address PO 5159		City Greene City	State	Zip Code 34224
Date of Sale 12/20/13		Selling price \$1800 -		

2. Odometer Disclosure Statement (Required For a Motor Vehicle)

Federal and State law requires that you state the mileage in connection with the transfer of ownership. Failure to complete or providing a false statement may result in fines and/or imprisonment.

WE STATE THAT THIS MOTOR VEHICLE'S 5 DIGIT OR 6 DIGIT ODOMETER NOW READS . XX
(NO TENTHS) MILES, DATE READ ____/____/____, AND WE HEREBY CERTIFY THAT TO THE BEST OF OUR KNOWLEDGE THE ODOMETER READING:

1. REFLECTS THE ACTUAL MILEAGE. 2. IS IN EXCESS OF ITS MECHANICAL LIMITS. 3. IS NOT THE ACTUAL MILEAGE.

Affidavit (When applicable):

3. Certification

UNDER PENALTIES OF PERJURY, I DECLARE THAT I HAVE READ THE FOREGOING DOCUMENT AND THAT THE FACTS STATED IN IT ARE TRUE.

Seller's Signature Saxby Marine	Seller's Printed Name Saxby Marine	Date 12/20/13
Seller's Address 185 S. JACKSON Rd	City Venice	State FL
		Zip Code 34292
Co-Seller's Signature (when applicable) Benjamin Saxby	Co-Seller's Printed Name (when applicable) Benjamin Saxby	Date 12/20/13
Co-Seller's Address (when applicable)	City	State
		Zip Code
Purchaser's Signature	Purchaser's Printed Name	Date
Co-Purchaser's Signature (when applicable)	Co-Purchaser's Printed name (when applicable)	Date

OWNERSHIP STATUS FOR THE ABOVE DESCRIBED MOTOR VEHICLE, MOBILE HOME, OFF-HIGHWAY VEHICLE OR VESSEL WILL NOT CHANGE UNTIL THE PURCHASER APPLIES FOR AND IS ISSUED A CERTIFICATE OF TITLE.

3.E



DOLPHIN MARINE SERVICES

3255 Placida Road
GROVE CITY, FL 34224
(941) 697-5200

QTY.	PART NO. AND DESCRIPTION (All parts new unless otherwise specified)	AMOUNT
1	steering cable	135.00
1	oil filter	12.00
1	water pump impeller	20.00
1	gear oil	14.00
1	propeller	200.00

NAME: *Tash Boyer LGWU*
 ADDRESS:
 CITY: STATE: ZIP:
 YEAR, MAKE AND MODEL:
 SERIAL NO./V.I.N.:

DATE IN	A.M. P.M.	DATE PROMISED	A.M. P.M.
CUSTOMER'S ORDER NO.		ORDER WRITTEN BY	
BUS. PHONE		EXT.	
HOME PHONE			
LICENSE NO.		MILEAGE	
CALL WHEN READY <input type="checkbox"/> YES <input type="checkbox"/> NO		MECHANIC/TECHNICIAN	
TERMS			

381.00

SERVICES REQUESTED/DESCRIPTION OF WORK

AMOUNT

replace steering cable	1h.	80.00
replace water pump impeller change gear oil	1 1/2 h	120.00
install battery switch	3h.	40.00
sand bottom never been painted		110.00
paint bottom \$18 per ft. 22 ft.		396.00

Jack

TOTAL PARTS

**LOCAL CHECK OR CASH ACCEPTED UPON DELIVERY
THANK YOU**

I hereby authorize the above repair work to be done along with the necessary materials. You and your employees may operate vehicle for purposes of testing, inspection, or delivery at my risk. An express mechanics lien is acknowledged on above vehicle to secure the amount of repairs thereto. It is understood that you will not be held responsible for loss or damage to vehicle or articles left in vehicle in case of fire, theft or any other cause beyond your control.

SIGNATURE _____ SAVE OLD PARTS YES NO

ESTIMATED COSTS

PARTS	LABOR	TOTAL
AUTHORIZED BY _____	<input type="checkbox"/> IN PERSON <input type="checkbox"/> BY PHONE	
DATE _____	TIME _____	CALLED BY _____
		PHONE _____

REVISED ESTIMATE / ADDITIONAL WORK

PARTS	LABOR	TOTAL
AUTHORIZED BY _____	<input type="checkbox"/> IN PERSON <input type="checkbox"/> BY PHONE	
DATE _____	TIME _____	CALLED BY _____
		PHONE _____

TOTAL LABOR 350.00
 TOTAL PARTS 381.00
 TOTAL SUBLET 396.00
 GAS, OIL AND GREASE

EPA / WASTE DISPOSAL 1127.00
 TAX 78.89
TOTAL 1205.00

Date -50-13
M Jack Boyer

Address _____

Reg. No.	Clerk	Account Forward
1	R. Evans	
2	Right wheel	
3	Reaming	
4		
5	ON TRAIL	
6		\$ 55.00
7		
8		
9	Jack	
10		
11	# 3866	
12		
13		
14		
15		

Office Expenses for LGWU

office rent ~~492.50~~ 292.50

Water 75.00/mn average

Elec runs 150.00/mn average

LGWU pays nothing towards
elec & water

So lets say 10%

Water 7.50 per month \$90 per yr

Elec 15.00 per month \$180 per yr

LITTLE GASPARILLA WTR UTIL INC.

4112

Paul Richardson

3/11/2014

292.50
200.00

BB&T

492.50

LITTLE GASPARILLA WTR UTIL INC.

4112

Paul Richardson

3/11/2014

*Rent
Dock*

292.50
200.00

BB&T

492.50

RENT for office of LGWU

CIGNA HealthCare
PO Box 30365
Tampa FL 33630-3365

Agent ID #

#6.A



Policy Specification Page

Open Access 10000/100%
Benefit Option Code: OA008

mycigna.com

Insured:	JOHN BOYER		
Identification Number:	See Member ID Card	Policy Effective Date:	12/01/2010
Form Number:	FLIND072009	Plan Number:	4700050
Benefit Option Code:	OA008	Annual Deductible	\$10,000.00 Individual \$20,000.00 Family

This Policy Specification Page is part of and incorporated into the Policy identified by the Identification Number and Form Number shown above.

Please read the copy of the application attached to this Policy. Carefully check the application and write to:

CIGNA
Individual Services
PO Box 30365
Tampa, FL 33630-3365

within 10 days, if any information shown on it is not correct and complete, or if any past medical history has been left out of the application. This application is part of the Policy and the Policy was issued on the basis that the answers to all questions and the information shown on the application are correct and complete.

This Policy is generally subject to a Pre-Existing Condition exclusion that runs 12 months from the Effective Date. This exclusion period may be reduced by qualified Creditable Coverage from your prior health plan. Listed below for each Insured Person is the Pre-Existing Condition End Date as determined from the information we may have received regarding your Creditable Coverage.

If you disagree with the amount of coverage with which you are being credited, please submit an additional evidence of Creditable Coverage to CIGNA at the above listed address.

INSURED PERSON(S) UNDER THIS PLAN

Name	Original Effective Date	Preexisting Condition End Date	Monthly Premium
JOHN BOYER	12/01/2010	N/A	\$266.00

Changed - electronically from 0230143001 to 1100000521408 Routing # [redacted]

■ BUSINESS VALUE 500 CHECKING 1100000521408 (continued)

DATE	CHECK #	AMOUNT(\$)	DATE	CHECK #	AMOUNT(\$)	DATE	CHECK #	AMOUNT(\$)
03/10	4108	1,305.25	03/14	4113	1,696.01	03/31	*4123	175.00
03/03	4109	676.37	03/19	4114	136.00	03/31	*4125	34.01
03/03	4110	625.00	03/31	*4116	270.28	03/28	*4131	2,571.61
03/03	4111	1,134.77	03/31	*4118	131.42	03/28	4132	1,305.25
03/14	4112	492.50	03/31	4119	60.00	03/28	4133	677.48
							Total checks	= \$12,555.57

* indicates a skip in sequential check numbers above this item

Other withdrawals, debits and service charges

DATE	DESCRIPTION	AMOUNT(\$)
03/03	ACH CORP DEBIT CL PYMT BB&T OF FL XXXXXXXXXXXX0001	920.43
03/03	ACH CORP DEBIT SIGONFILE Charlotte County LITTLE GASP WATER UTIL	1,000.00
03/05	ISA PAYMNT NORTHWESTERN MU 9-01 JOHN R BOYER	289.67
03/05	8774845967 CIGNA 877-484-59 9014 JOHN BOYER JOHN BOYER	425.00
03/17	ACH CORP DEBIT USATAXPYMT IRS LITTLE GASPARILLA WATE	2,717.59
03/21	SERVICE CHARGES - PRIOR PERIOD	3.00
Total other withdrawals, debits and service charges		= \$5,355.69

Deposits, credits and interest

DATE	DESCRIPTION	AMOUNT(\$)
03/12	DEPOSIT	✓ 163.64
03/12	DEPOSIT	✓ 2,495.37
03/14	DEPOSIT	✓ 1,085.48
03/17	DEPOSIT	✓ 1,191.32
03/20	DEPOSIT	✓ 471.38
03/27	DEPOSIT	✓ 1,709.12
03/27	DEPOSIT	✓ 2,958.54
03/27	DEPOSIT	✓ 2,990.64
03/27	DEPOSIT	✓ 4,137.41
03/31	DEPOSIT	✓ 512.13
03/31	DEPOSIT	✓ 3,019.07
03/31	DEPOSIT	✓ 3,296.48
03/31	DEPOSIT	✓ 3,682.76
Total deposits, credits and interest		= \$27,713.34

Golden Rule

A UnitedHealthcare Company
P.O. Box 31372
Salt Lake City, UT 84131-0374

6A.

March 31, 2014

08864746LA025380001

LITTLE GASPARILLA WATER UTILIT
PO BOX 5159
1916 MICHIGAN
ENGLEWOOD FL 34224-0159

Subject: ID Number 059-408-521

Dear Ms. Boyer:

Thank you for your interest in the Electronic Funds Transfer (EFT) method of paying for your insurance plan.

We will be forwarding the March and April automatic charge for \$852.84 to your bank on or around April 15, 2014. We will then resume drafting on your regularly scheduled draft day of the 15th of each month beginning in May for \$426.42.

Since you are set up on our automatic payment plan, you will no longer be charged the \$10 direct bill fee. The fee has been removed from the payment listed above.

As requested, we have added Little Gasparilla Water Utility as the payor on your plan.

If you have questions, please contact our office. Customer service representatives are available to assist you.

Sincerely,

Policy Administration

cc: LITTLE GASPARILLA WATER UTILIT

#6B

A Basic Life Insurance Illustration

Prepared For:
John R. Boyer

Prepared By:
Adam E Nelson, Agent
STE 230
10070 DANIELS INTRSTE CT
FORT MYERS FL 33913
(239) 985-2800
May 1, 2013

Narrative Summary

Insured: John R. Boyer
Male, Age 58
Underwriting Class: Premier.
Dividend Option: Either reduce premium or cash options
Conversion Period: During the first 10 policy years
Policy Type: Level Term 20
Policy Number: 20-282-051

Initial Insurance Amount: \$750,000
Initial Contract Premium: \$3,356.50 Annually (see Premium Summary for other premium frequencies)
Premium Payable: To policy anniversary nearest insured's 80th birthday

L20 - This is a level insurance amount term life insurance policy. The premiums are guaranteed level for 20 years. Premiums increase annually in years 21-25 and are guaranteed. It has no cash surrender value.

Guaranteed Amounts - These numbers are based on the assumption that no dividends are paid and that Northwestern Mutual Life is charging the maximum premiums allowed in the contract. The premiums are guaranteed level for 20 years.

Non-Guaranteed Amounts - These numbers are based on the assumption that the non-guaranteed amounts currently illustrated will continue unchanged for all years shown. Northwestern Mutual Life is required to state that this is not likely to occur and that actual results may be more or less favorable. The premiums are guaranteed level for 20 years.

Illustrated Dividends are based on the assumption that the non-guaranteed dividends currently illustrated will continue unchanged under the assumed dividend scale for all years shown. This is not likely to occur; actual results may be more or less favorable. Future dividends may be larger or smaller than illustrated as a result of changes in the dividend scale and/or any policy changes you make, which includes changing the face amount and adding or dropping additional benefits.

Conversion Rights - During the conversion period, this policy may be converted to a single life permanent policy with the same Additional Benefits without providing further evidence of insurability. The insurance amount on the resulting permanent policy can be equal to or less than this policy's insurance amount, and is subject to established Northwestern Mutual Life minimums.

720 East Wisconsin Avenue
 Milwaukee, Wisconsin 53202
 www.northwesternmutual.com

Payment Information Notice

Account Number: 1657539

Prepared: May 2, 2013

Questions About This Notice?

www.northwesternmutual.com

Call: 1-800-388-8123

10129B21210002691

John R Boyer
 PO Box 5145
 Grove City FL 34224

Your Financial Representative

Adam E Nelson
 Ste 230
 10070 Daniels Intrste Ct
 Fort Myers FL 33913
 (239) 985-2800

Page 1 of 1

121000269140000Q 2937

Policies Paid by Your Insurance Service Account (ISA) Plus

See reverse side for an Explanation of Terms

Insured	Life Policy No.	Type of Policy	Monthly Premium	Total Payment
John R Boyer	20-282-051	Lvl Term 20	\$289.67	\$289.67
Life Sub-Totals			\$289.67	= \$289.67

The amount due changed because either you requested a change or minimum account requirements for premiums or special services changed.

Sub-Total for Life Policies \$289.67

Monthly Payment Due May 4 **\$289.67**

ISA Surplus as of May 2, 2013: \$84.36.
 Currently earning interest of .02%. Rates change weekly.

Revised

In accordance with the Terms of this Insurance Service Account Agreement, Northwestern Mutual will draw

\$289.67 on the 4th of each month

from BRANCH BANKING AND TRUST CO Account Number XXXXXXXXXX1408

Important: Please notify Northwestern Mutual Policyowner Services Department or your Financial Representative immediately if you plan to close this bank account or change your address. Please include your ISA Number **1657539** in any correspondence.

Thank you for your business.



Simplified Employee Pension (SEP) Plans

Description

A Simplified Employee Pension (SEP) Plan is a type of business retirement plan that allows an employer to contribute tax-deductible dollars to the owner's and the employee's retirement account. SEP IRA plans are funded in a similar manner as a Profit Sharing plan, in the sense that each eligible employee generally gets the same percentage of their individual compensation amount, and that percentage is at the discretion of the owner(s) from year to year.

The SEP can be set up by any type of business, including a sole proprietor, partnership, corporation (S or C), non-profit organization, and government entity.

Contributions

- Contributions to the accounts of eligible employer(s) and employee(s) are made entirely by the business.
- The contributions are a business tax deduction and grow tax deferred until distribution.
- The contribution limit is the lesser of 25 percent of compensation or \$51,000 (2013) and \$52,000 (2014).
- The compensation cap on which SEP contributions can be based is \$255,000 (2013) and \$260,000 (2014).
- Annual contributions to the plan are not mandatory, and may range from 0 to 25 percent.

Eligibility

An employer can elect to exclude employees using multiple requirements. The employer can require the employee to:

- Attain age 21, and,
- Perform services during at least three of the immediately preceding five years (there is no number of hours requirement, and no distinction between full and part-time employees), and,
- Have current compensation of at least \$550 (2013/2014).
- The employer can also exclude those employees covered by a collective bargaining agreement (generally union employees) and non-resident aliens.

The employer can reduce or eliminate these requirements if desired. Employers are subject to the same eligibility requirements as the employees.

Vesting

The SEP IRA does not offer a vesting schedule. All contributions are immediately 100 percent vested to the employee.

Deadlines

An existing employer has until their tax-filing deadline including extensions to establish and fund a SEP IRA.

Rollovers

A rollover is a non-taxable distribution from an IRA that has been re-deposited into an IRA within 60 calendar days of the distribution. A distribution from an IRA can be rolled over only once in any 12-month period, beginning with the date the distribution is received.

Additional Information

- Low cost - The Simplified Employee Pension is an inexpensive business retirement plan.
- Requires no special IRS filing - Simplified Employee Pension Plans do not require the filing of IRS form 5500.

Edward Jones, its employees and financial advisors do not provide tax or legal advice. This information is believed to be reliable, but its accuracy and completeness are not guaranteed. It should be used for broadly informational purposes only. You should consult with your tax professional for advice about your specific situation.

CUSTOMER NAME: BOYER, JOHN R
ACCOUNT NUMBER: 289-99802

DESTINATION: NEW ACCOUNTS
BRANCH #: 92897 DATE: 03/06/2014

**EDWARD JONES INDIVIDUAL RETIREMENT ACCOUNT
AUTHORIZATION FORM AND BENEFICIARY DESIGNATION**

A. ACCOUNT HOLDER INFORMATION

Account Holder Name JOHN R BOYER
Account Holder Address PO BOX 5145
City/State/Zip GROVE CITY, FL 34224
Date of Birth/Trust 01/21/1955 Social Security Number [REDACTED]

B. TYPE OF ACCOUNT (INDICATE ONE) Traditional IRA Roth IRA SEP IRA SIMPLE IRA

Inherited IRA No Yes

C. ACCOUNT HOLDER'S ACCEPTANCE. By signing below:

- Under penalties of perjury, I certify that the number shown on this form is my correct Taxpayer Identification Number.
- I acknowledge that I have received, read and understand the Edward Jones Custodial Agreement applicable to the type of account indicated above and agree to its terms, and have received the Disclosure Statement applicable to the type of account indicated above, Schedule of Fees for IRAs, Privacy Notice, and Revenue Sharing Disclosure.
- If I have designated any beneficiaries on the Edward Jones Beneficiary Designation Form, I have reviewed said designation form for accuracy, confirmed it is attached hereto and incorporated by reference.
- THE EDWARD JONES TRADITIONAL INDIVIDUAL RETIREMENT ACCOUNT CUSTODIAL AGREEMENT CONTAINS ON PAGE 5, ARTICLE VIII, SECTION 15, A BINDING ARBITRATION PROVISION, WHICH MAY BE ENFORCED BY THE PARTIES.**

(Please retain this copy for your records) JOHN R BOYER
Signature of Account Holder Account Holder's Name _____ Date _____
(or authorized representative of Account Holder)

**NO BENEFICIARY DESIGNATION FORM ATTACHED
CUSTODIAL AGREEMENT DEFAULT APPLIES**

Edward Jones Prototype SEP Plan General Information

1. Simplified Employee Pension Plan

A Simplified Employee Pension (SEP) is a written arrangement (a plan) that allows an employer to make deductible contributions for the benefit of participating employees. The contributions are made to individual retirement arrangements (IRAs) set up for participants in the Plan.

2. Employer Eligibility Requirements

The following conditions must be met in order for an employer to be eligible to set up an Edward Jones SEP Prototype Plan:

- The SEP Plan must be set up by an individual that controls a business from which his or her personal services are an income producing factor.
- An IRA has been set up for all eligible employees to receive contributions.
- The employer may be required to include leased employees and the employees of other business(es) as described below:
 - a) An affiliated service group described in section 414(m)
 - b) A controlled group of corporations described in section 414(b)
 - c) Trades or businesses under common control described in section 414(c)

3. Employee Eligibility Requirements

An eligible employee is an individual who meets the following requirements:

- Has attained age 21
- Has worked for the employer three of the last five preceding years
- Has received at least \$550.00 in compensation

An employer may exclude employees covered by a collective bargaining agreement, non-resident aliens, and employees who have earned less than \$550.00.

4. Contributions

An employer can decide from year to year if a SEP contribution will be made to the SEP Plan. The employer has until his/her tax filing deadline including extensions to make the SEP contribution to the Plan.

All SEP employer contributions must be made to each eligible employee's individual retirement account in the form of cash.

Under an Edward Jones Prototype SEP Plan, the employer may choose to make contributions under the percentage formula, flat dollar formula, or integrated formula. (See Edward Jones SEP Basic Plan Document for details).

5. Deducting Contributions

Generally, an employer can deduct the SEP contributions he/she makes for each employee. The most an employer can deduct for contributions for participants is the lesser of the following amounts:

- 1) Employer contributions (including any elective deferrals and excess contributions carryover)
- 2) 25% of each participant's compensation, (Annual compensation limited to \$255,000 for 2013 and \$260,000 for 2014 may be adjusted for cost-of-living) during the plan year

For details on deductions and deduction limits for self-employed individuals and deduction limits for multiple plans, see IRS Publication 560.

6. Employee Notices

The following information must be provided to each employee (participant):

- Edward Jones Simplified Employee Pension Adoption Agreement (SEP)
- Edward Jones SEP Basic Plan Document and SEP Disclosure Information
- An employer must provide to each participant of the SEP Plan an individual statement detailing his/her SEP contribution totals and any excess contribution notices

7. Distributions

An employer may not prohibit participants of the SEP from taking distributions from their individual retirement accounts (IRAs).

8. Tax Consequences

Before establishing an Edward Jones SEP Prototype Plan, please consult with a qualified attorney or tax advisor. Edward Jones does not issue an opinion as to and is not responsible for the tax consequences of the Adoption of an Edward Jones SEP Prototype Plan.

SEP

25% per year of Annual Salary

John R Boyer	18975.00
Diane K Boyer	4500.00
Ashton D Boyer	3881.25
Audrey Rice (Vokes) approx	2000.00

8b

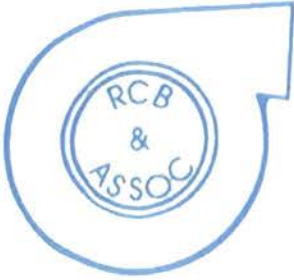

RC BEACH & ASSOC. INC.

539 SAN CHRISTOPHER DRIVE DUNEDIN, FLORIDA 34698 USA
PHONE (727) 736-3696 FAX (727) 733-2647
WWW.RCBEACH.COM

Pump #2 122 GPM 125 TDH 7.5 HP 100% of Sys Flow Model: AP-2-7-A NSF-61/CA. Low Lead Approved System 3" Stainless Steel Header w/ Grooved Flange Adapters ODP Variable Speed Motor Frame STD Skid Base Variable Frequency Drive for Each Pump Pump Check Valve 6 Week Delivery Options Panel Enclosure: NEMA 12 Standard Enclosure Surge Protection Device Flow Sensor / Transmitter / Display / Staging (Sensor/Transmitter/Spool Shipped Loose) Copper Sensing Lines Modbus TCP Communications Factory Flow Test Factory HydroStatic Test Certified X + Y Plot Test at Duty Point Freight Included to State: FL				
Line #	Qty	Description	Price Ea.	Extended
	1	Total Quote Price		\$18765.00

Shipping Notes

Quote Last Updated: 5/9/2014

By: Craig Dickinson

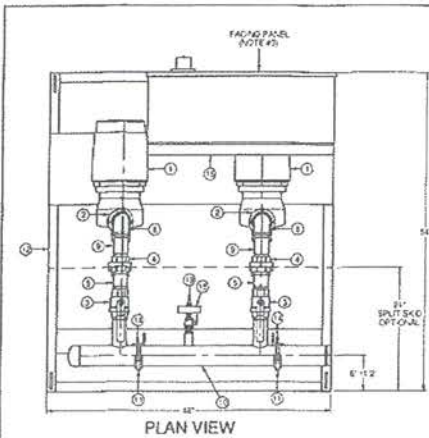

PLAN VIEW

NOTES:

1. THE HEADER ORIENTATION DEPICTED IN THIS DRAWING IS FOR REFERENCE ONLY.
2. REGARDLESS OF HEADER ORIENTATION, THE OPEN END OF THE HEADER IS TO BE FLUSH WITH THE EDGE OF THE SKID.
3. WHEN FACING THE CONTROL PANEL, THE SUCTION AND DISCHARGE CONNECTION WILL NEED TO BE DETERMINED BY THE CUSTOMER (PLEASE INDICATE ON THE CHART BELOW)

HEADER ORIENTATION	LEFT	RIGHT
SUCTION CONNECTION		
DISCHARGE CONNECTION		

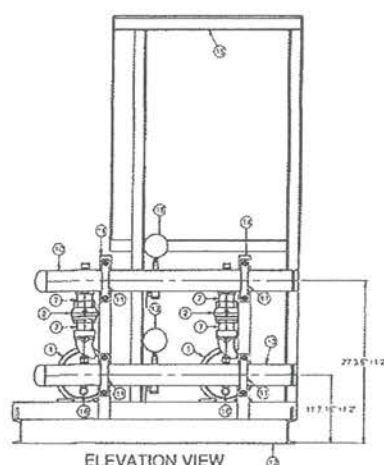
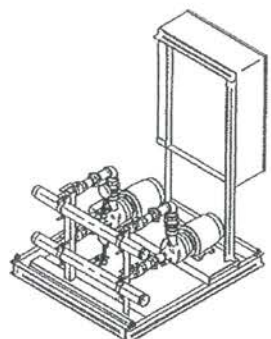

ELEVATION VIEW

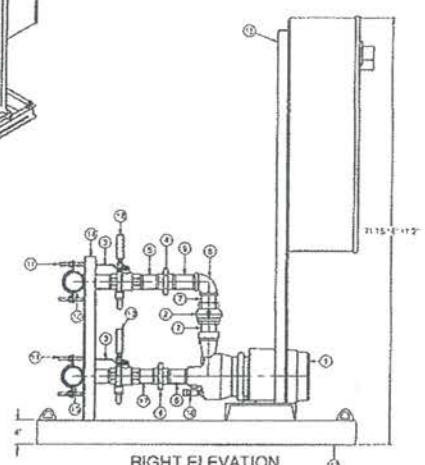

RIGHT ELEVATION

THIS DOCUMENT CONTAINS DESIGNS AND OTHER INFORMATION WHICH ARE THE CONFIDENTIAL PROPERTY OF PATTERSON PUMP COMPANY. THE RECIPIENT ACKNOWLEDGES THAT THIS IS FURNISHED FOR ITS PRIVATE USE AND UPON THE EXPRESS AGREEMENT THAT IT WILL NOT REPRODUCE, COPY, EXHIBIT OR LEND IT IN WHOLE OR IN PART FOR ANY PURPOSE WHATSOEVER WITHOUT THE PRIOR WRITTEN CONSENT OF PATTERSON PUMP COMPANY.

PRELIMINARY DRAWINGS NOT FOR CONSTRUCTION

QUOTE NO.: _____
 PROJECT NAME: _____
 TOTAL STATION FLOW: _____
 SUCTION PRESSURE: _____
 PRESSURE BOOST: _____
 TOTAL DISCHARGE PRESSURE: _____

Qty	Chg	Qty	Chg
1		2	
2		2	
3		4	
4		5	
5		6	
6		7	
7		8	
8		9	
9		10	
10		11	
11		12	
12		13	
13		14	
14		15	
15		16	
16		17	
17		18	
18		19	

CERTIFIED FOR APPROVAL ONLY X
 CERTIFIED FOR CONSTRUCTION _____

DATE: 11/22/2012
 SCALE: 1:1
 SHEET: 1 of 1

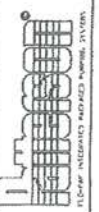

JOB TITLE:
 VFD DUPLEX AQUA-FLOPAC LOW LEAD
 DAP-2-7-A-3 VFD 2X2X6

REV. DATE: 11/22/2012

TOP VIEW

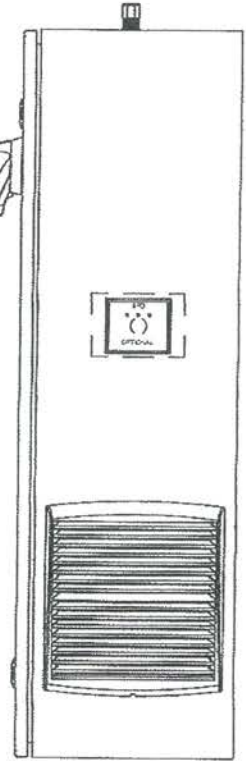
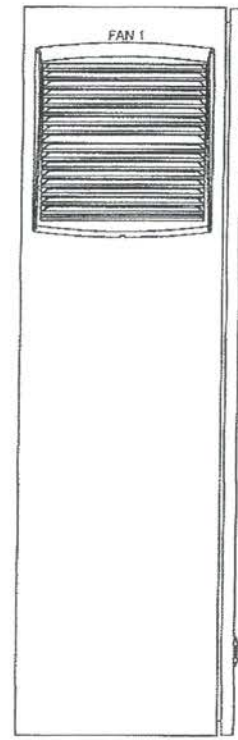
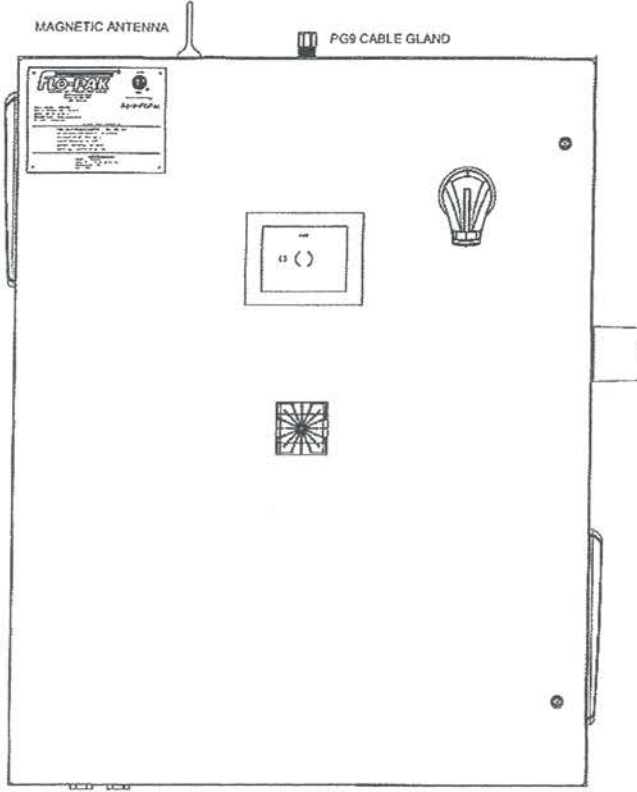
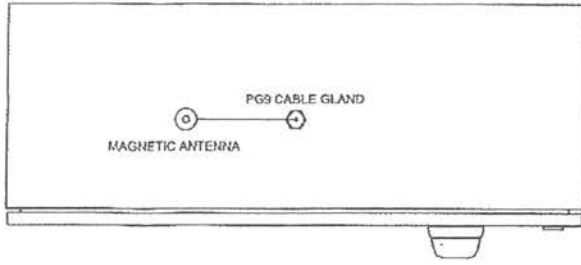

L/H SIDE VIEW

R/H SIDE VIEW

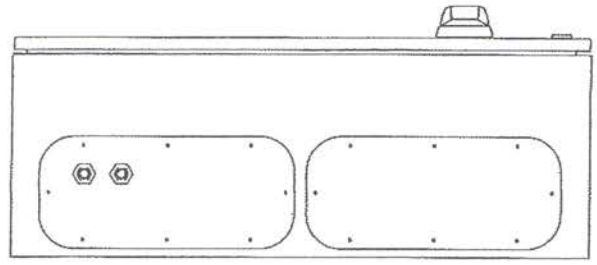

BOTTOM VIEW

Duplex Variable Speed Panel

Enclosure Type	Height	Width	Depth		Page 1
Nema Type 12	39.37"	31.5"	11.93"		

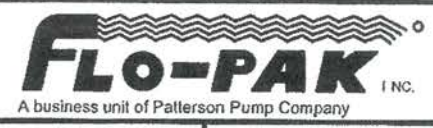

Drawn By: WRW	Date: 01/16/2014
Drawing Number: A85-128382-1	Rev. 1

TOP VIEW

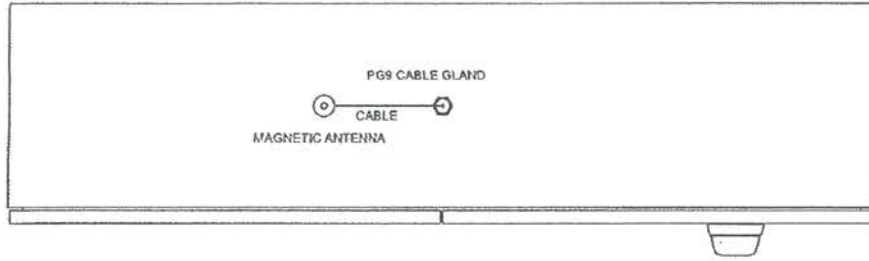

MAGNETIC ANTENNA PG9 CABLE GLAND

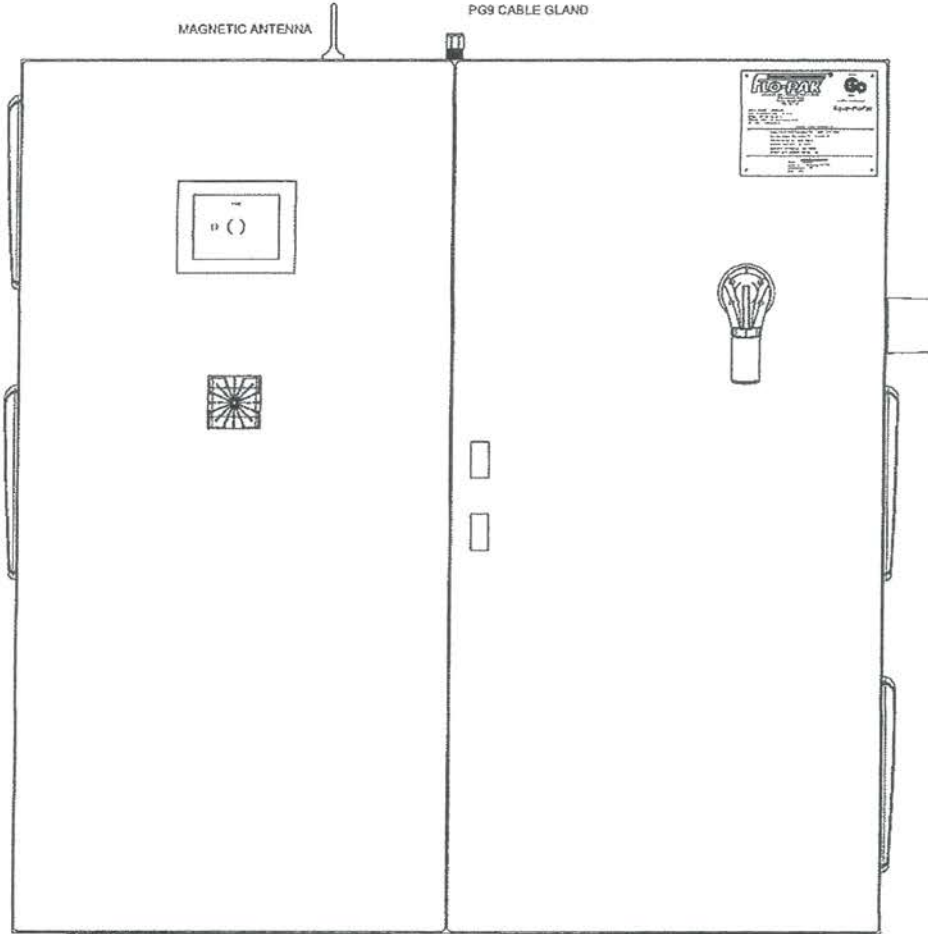

BOTTOM VIEW

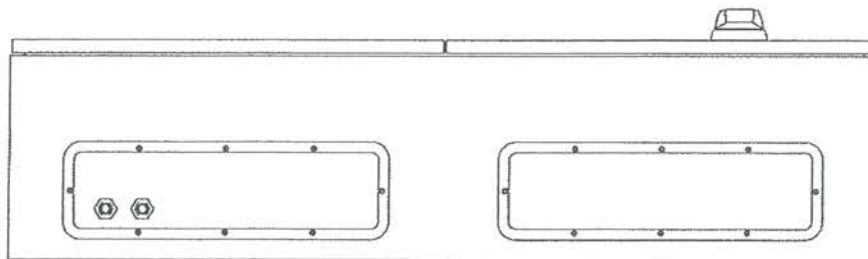

LE Duplex Variable Speed Panel

Enclosure Type	Height	Width	Depth		Page 1
Nema Type 12	47.24"	47.24"	11.90"		



Drawn By: WRW	Date: 01/16/2014
Drawing Number: A85-128390-1	Rev. 1

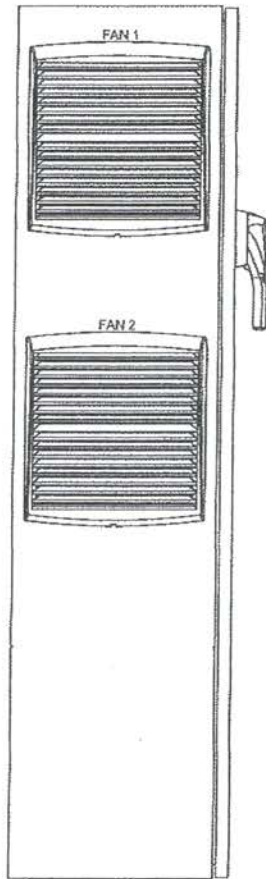

L/H SIDE VIEW

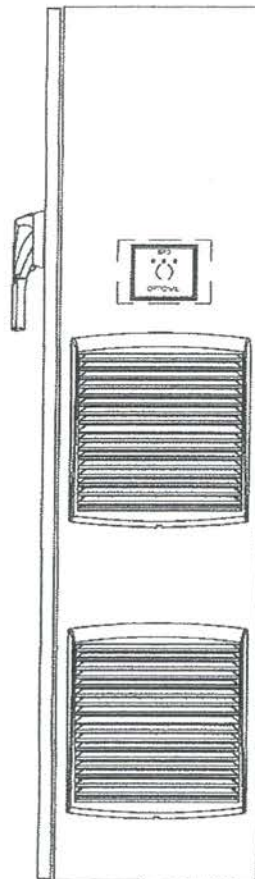

R/H SIDE VIEW

LE Duplex Variable Speed Panel

LE Duplex Variable Speed Panel					 A business unit of Patterson Pump Company	
Enclosure Type	Height	Width	Depth			
Nema Type 12	47.24"	47.24"	11.90"			Drawn By: WRW Date: 01/16/2014 Drawing Number: A85-128390-1 Rev. 1

MAGNETIC ANTENNA
 30A DISCONNECT
 PG9 CABLE GLAND

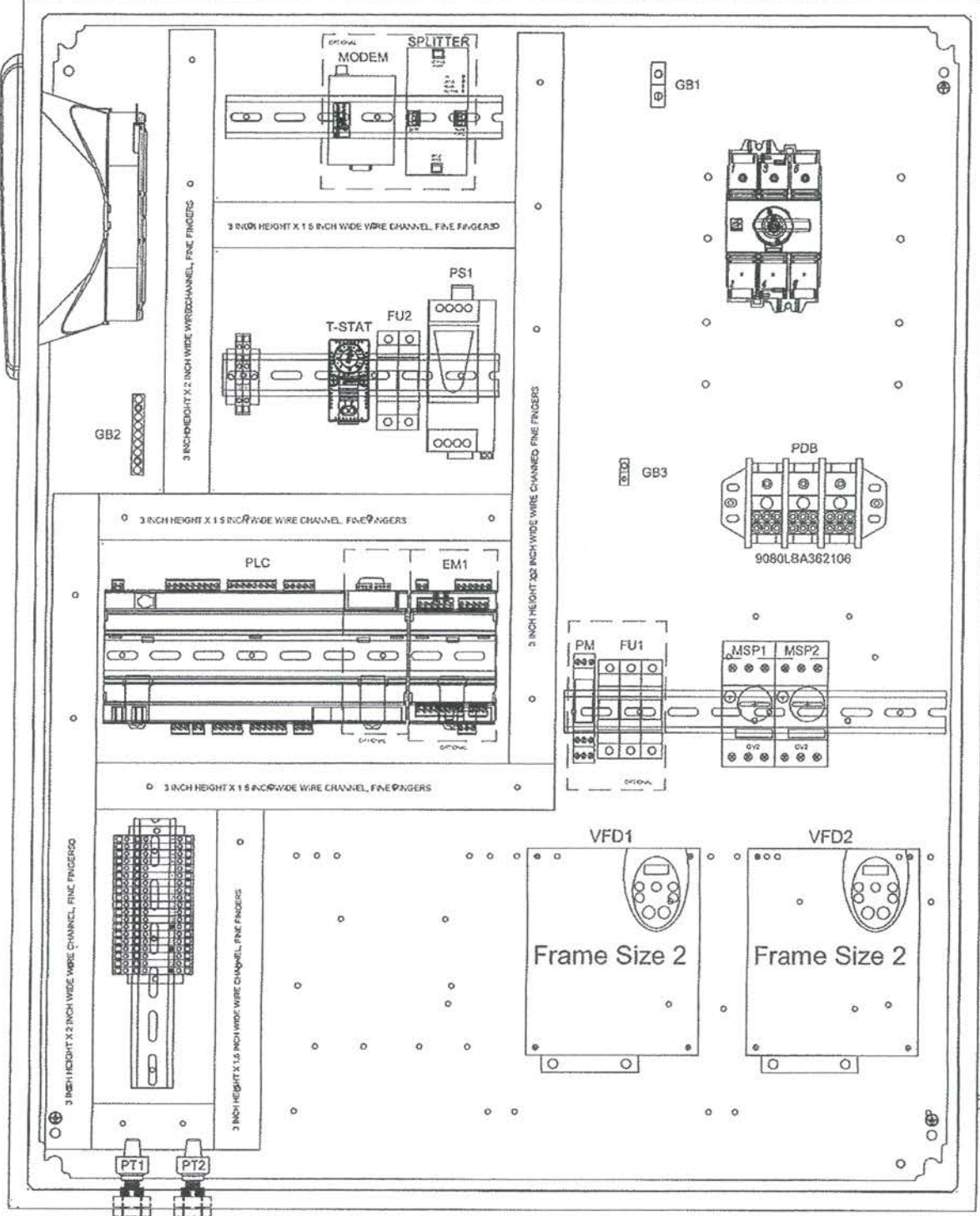

VOLTAGE	HP RATING	FRAME SIZE
480VAC	DAP - 5	2
480VAC	DAP - 7	2

Duplex Variable Speed Panel

Enclosure Type	Height	Width	Depth		Page 3
Nema Type 12	39.37"	31.5"	11.93"		

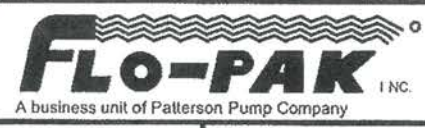

Drawn By: WRW	Date: 01/16/2014
Drawing Number: A85-128382-1	Rev. 1

TOP VIEW

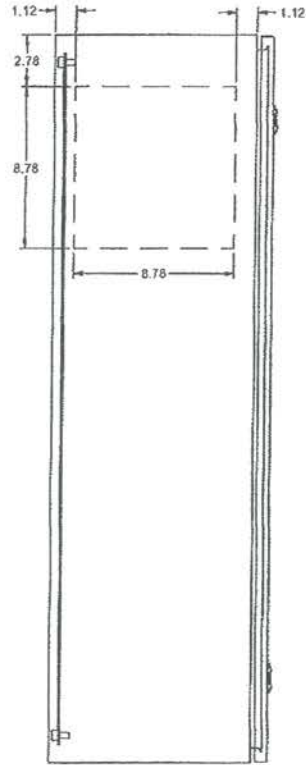
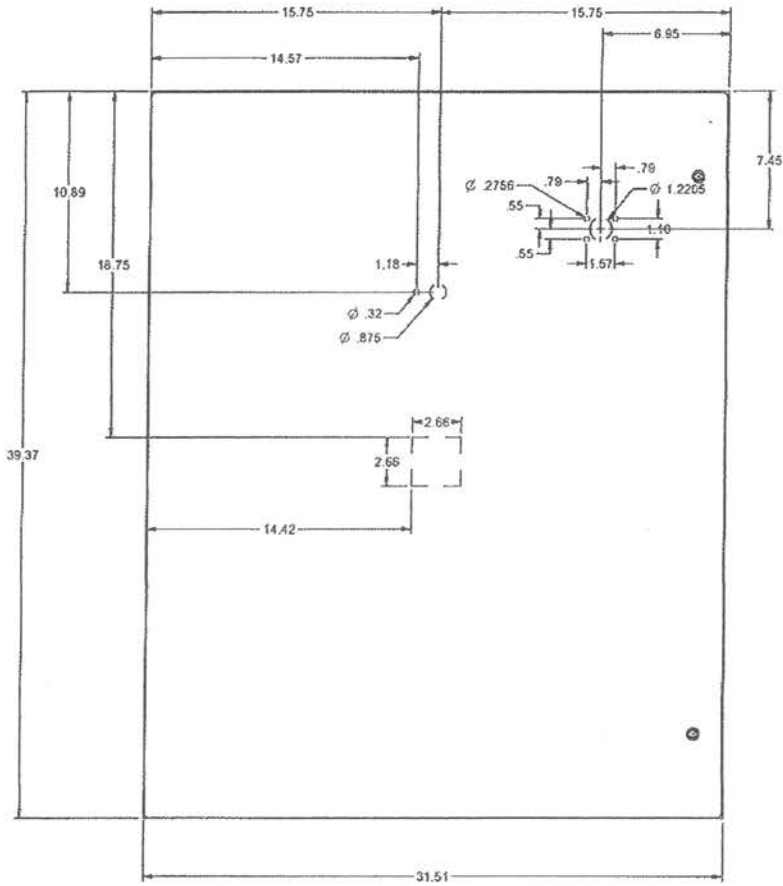
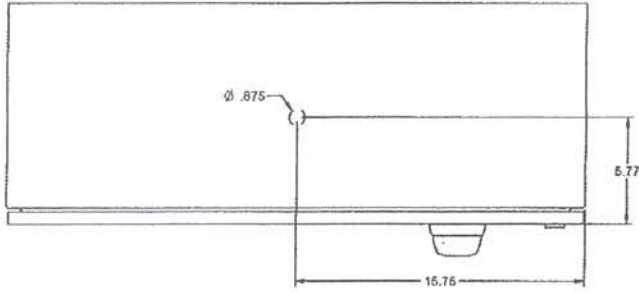

LH SIDE VIEW

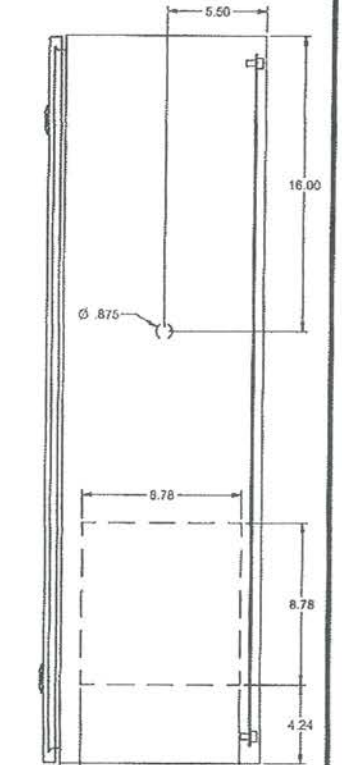

RH SIDE VIEW

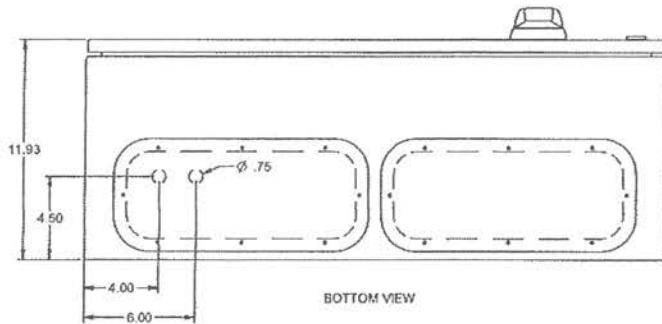

BOTTOM VIEW

Duplex Variable Speed Panel

Enclosure Type	Height	Width	Depth		Page 8
Nema Type 3R	39.37"	31.5"	11.93"		



Drawn By: WRW	Date: 01/16/2014
Drawing Number: A85-128382-1	Rev. 1

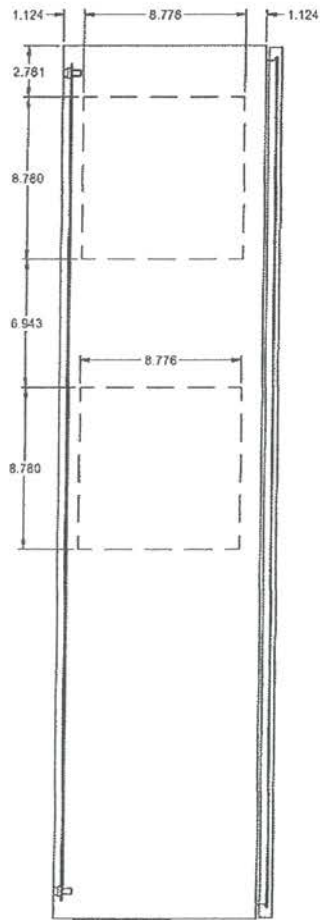

LH SIDE VIEW

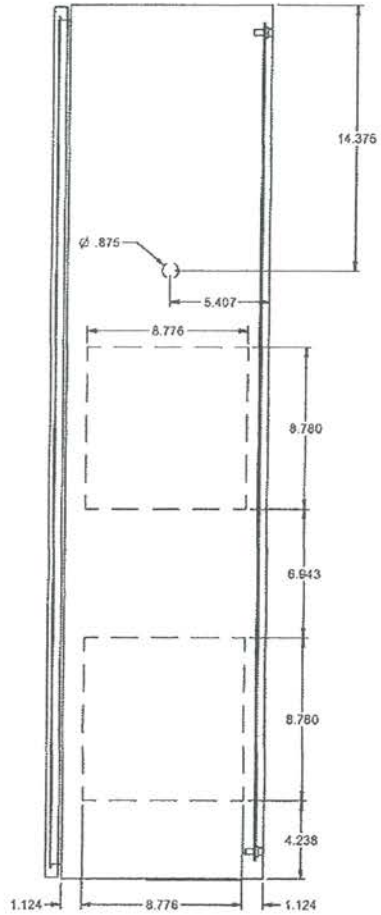

RH SIDE VIEW

LE Duplex Variable Speed Panel

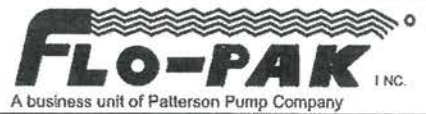

Enclosure Type	Height	Width	Depth		Page 9
----------------	--------	-------	-------	--	--------

Nema Type 12	47.24"	47.24"	11.90"		
--------------	--------	--------	--------	--	--

Drawn By: WRW	Date: 01/16/2014
---------------	------------------

Drawing Number: A85-128390-1	Rev. 1
------------------------------	--------

1. Water Distribution System Category I				
Distribution System	Level 1	Level 2	Level 3	Level 4
Distribution system connected to a Class A, B, or C water treatment plant.	<p>Serving 100,000 or more persons.</p> <p>The lead/chief operator must be a Level 1 water distribution system operator or a Class C or higher water treatment plant operator. Additionally, a Level 3 or higher water distribution system operator or a Class C or higher water treatment plant operator shall be in on-site charge of any water distribution system operation or maintenance activity that may affect water quality or quantity and that is listed in Footnote 1 below unless the activity is being performed by a licensed contractor working within the scope of his or her license.²</p>	<p>Serving at least 10,000 persons and less than 100,000 persons.</p> <p>The lead/chief operator must be a Level 2 or higher water distribution system operator or a Class C or higher water treatment plant operator. Additionally, a Level 3 or higher water distribution system operator or a Class C or higher water treatment plant operator shall be in on-site charge of any water distribution system operation or maintenance activity that may affect water quality or quantity and that is listed in Footnote 1 below unless the activity is being performed by a licensed contractor working within the scope of his or her license.²</p>	<p>Serving at least 1,000 persons and less than 10,000 persons.</p> <p>The lead/chief operator must be a Level 3 or higher water distribution system operator or a Class C or higher water treatment plant operator. Additionally, a Level 3 or higher water distribution system operator or a Class C or higher water treatment plant operator shall be in on-site charge of any water distribution system operation or maintenance activity that may affect water quality or quantity and that is listed in Footnote 1 below unless the activity is being performed by a licensed contractor working within the scope of his or her license.²</p>	<p>Serving less than 1,000 persons³</p> <p>The lead/chief operator must be a Level 4 or higher water distribution system operator or a Class D or higher water treatment plant operator. Additionally, a Level 4 or higher water distribution system operator or a Class D or higher water treatment plant operator shall be in on-site charge of any water distribution system operation or maintenance activity that may affect water quality or quantity and that is listed in Footnote 1 below unless the activity is being performed by a licensed contractor working within the scope of his or her license.²</p>

¹ The following water distribution system operation or maintenance activities may affect water quality or quantity: cleaning (swabbing, pigging, scraping, or air-purging) existing or repaired water mains; tapping, depressurizing/dewatering, or disinfecting existing or repaired water mains; dewatering, cleaning, or disinfecting existing or repaired finished-water storage tanks; and manually operating pumps, or adjusting automatic pump controls or automatic control valves, as necessary to regulate water distribution system flows or pressures.

² Part I of Chapter 489, F.S., and rules adopted thereunder and administered by the Department of Business and Professional Regulation and the Construction Industry Licensing Board regulate the construction industry and establish whether construction work, including the repair or replacement of water distribution system facilities, must be performed by a licensed contractor.

³ For wholesale systems, a Category I water distribution system serving less than 1,000 persons shall be classified as a Level 3 water distribution system.

#10

Meter #

6/8/1998 J - PLACIDA BEACH CONDOS - Bldg 100 1053.78
 6/8/1998 ✓ ✓ ✓ Bldg 200 1052-07,
 6/8/1998 ✓ ✓ ✓ Bldg 300 1067-07
 6/8/1998 ✓ ✓ ✓ Bldg 400 1021-964
 6/8/1998 ✓ ✓ ✓ Bldg 400 4444-A-80
 10/1/2004 PLACIDA HARBOR CLUB. Bldg 400 973
 6/8/1998 PLACIDA HARBOR (POOL) 20253127

3/10/1999 B - Cone DARNELL - dock

6/8/1998 D - Home owners Assoc. dock 1057 D687
 6/8/1998 Gasp. Hideaway - dock. 1055 D930
 3/21/2002 SAM JONES - dock 1134 D438

9/1/2004 E - MARY ANN DiFRANK 4444E 367
 FREEMAN ~~XXXXXXXXXX~~

3/1/2004 H - Beach Club Hideaway - Fire Pump. 1082 H 537
 Beach Club Pool 1079 I 273
 6/8/1998 Beach Club Hideaway Sewer Plant 2024 H 55-
 3/3/2004 House We Stade in 914M

9/1/2004 M Bob Hill - home 068M
 3/17/2010 Robert Thomas - dock 670M.1
 Brian Mills

*Fernal 10 Docks
Swimming Pool
Fire House*

Table 4.1

CIAC and Accumulated Amortization

	12/31/1999	Additions	12/31/2000	Additions	12/31/2001	Additions	12/31/2002	Additions	12/31/2003	Additions	12/31/2004	Additions	12/31/2005	Additions	12/31/2006
CIAC	\$ -	\$ (49,500)	\$ (49,500)	\$ (22,500)	\$ (72,000)	\$ (45,000)	\$ (117,000)	\$ (22,500)	\$ (139,500)	\$ (153,000)	\$ (292,500)	\$ (81,000)	\$ (373,500)	\$ (94,500)	\$ (468,000)
Amtz. CIAC	\$ -	\$ 619	\$ 619	\$ 1,519	\$ 2,138	\$ 2,363	\$ 4,500	\$ 3,206	\$ 7,706	\$ 5,400	\$ 13,106	\$ 8,325	\$ 21,431	\$ 10,519	\$ 31,950

	Additions	12/31/2007	Additions	12/31/2008	Additions	12/31/2009	Additions	12/31/2010	Additions	12/31/2011	Additions	12/31/2012	Additions	09/30/2013
CIAC	\$ (40,500)	\$ (508,500)	\$ (13,500)	\$ (522,000)	\$ (18,000)	\$ (540,000)	\$ (18,000)	\$ (558,000)	\$ (13,500)	\$ (571,500)	\$ (27,000)	\$ (598,500)	\$ (18,000)	\$ (616,500)
Amtz. CIAC	\$ 11,194	\$ 43,144	\$ 12,881	\$ 56,025	\$ 13,275	\$ 69,300	\$ 13,725	\$ 83,025	\$ 14,119	\$ 97,144	\$ 14,625	\$ 111,769	\$ 11,391	\$ 123,159

Average CIAC \$ (607,500)
Average Acc. Amtz. CIAC \$ 115,636

Rate of 2.5% used/1/2 year convention

Year	2000	2001	2002	2003	2004	2005	2006	Total Connections
Connections	11	5	10	5	34	18	21	104
Capacity Charge per Tariff	\$ 4,500	\$ 4,500	\$ 4,500	\$ 4,500	\$ 4,500	\$ 4,500	\$ 4,500	\$ 4,500
Total	\$ 49,500	\$ 22,500	\$ 45,000	\$ 22,500	\$ 153,000	\$ 81,000	\$ 94,500	

Year -	2007	2008	2009	2010	2011	2012	2013
Connections	9	3	4	4	3	6	4
Capacity Charge	\$ 4,500	\$ 4,500	\$ 4,500	\$ 4,500	\$ 4,500	\$ 4,500	\$ 4,500
Total	\$ 40,500	\$ 13,500	\$ 18,000	\$ 18,000	\$ 13,500	\$ 27,000	\$ 18,000

2000 - 2006 - PSC Annual Reports
2008 - 2010 agrees with County SAR and/or books
2011, 2012 and 2013 - Utility's books
Total customers added 2000 - 2013
Total customers at 9/6/13 per billing records
Remaining bal indicates customers at beginning of 2000

The Utility explained all general service customers were added in 1988 except for 2 that were added in 2004. Therefore the 2004 number of customers has been reduced since only residential customers are required to pay \$4,500 per the tariff dated 5/22/200:

*M Bob Hill - Home
Robert Thomas - a/cok. 914m
H - Beach Club Highway 1082H527
Beach Club Highway Pool
Beach Club Highway 1079E273
Beach Club Highway Sewer Plant 2024H553*

*E-4444 E 36.7 MARY ANN DOFRANK
FREEMAN*

Total Cust.	106
	26
	13
	139
	370
	231

*Doek. 1057D687
Doek. 1055D930
1134P4381053-789
Placida Beach Condominium Bldg 100
1032-071 Bldg 200
1067-077 Bldg 300
1021-964 Bldg 400
Placida Harbor 4444-A504
973 Placida Harbor Pool*

#12b

Home Mail News Sports Finance Weather Games Groups Answers Screen Flickr Mobile More

Search Mail Search Web

Jack



Compose

☰ Delete Move Spam View More Sponsored

- Inbox (4)
- Drafts
- Sent
- Spam (542)
- Trash
- ▼ Folders (17)
 - Accounting
 - appraisals
 - ATT
 - Boat
 - Britt
 - credit
 - Deleted Items (16)
 - e-bay
 - Erin's wedding
 - Farmers Market
 - forms
 - FPL-LGWU
 - HC LLC.
 - Holy Land 2012
 - Insurance
 - Investors
 - Islands
 - KU
 - Legal
 - LGWU
 - loans
 - Marinas
 - N.C. Property
 - Notes
 - OFF-THE-HOOK
 - O-T-H
 - PAT
 - Pedals Pushers
 - Pictures
 - PSC
 - Rocky Creek
 - Sent Items
 - Synced Messages
 - Taxes (1)
 - Testimonys
 - Wallace
 - YL

- ☀ Tam... Do You Want to Find a Great Relatio... Sponsored ^
- **LinkedI** See Shelly Shepard's new endorsement 3:23 PM
- Hubbard RE: LGWU ? 3:21 PM
- **NorCro** NorCross Marine sent you an invitation 2:45 PM
- **United** Young People in Mission, Team Openin! 2:22 PM

New Site Grants Access to Anyone's Public Record Instant Checkmate

Brand New Muscle Builder Takes GNC by Storm Force Factor

Credit Cards Now Offering 0% APR for 18 Months. CompareCards.com

Brand New Muscle Builder Takes GNC by Storm Force Factor

Bad News for Agents, Good News for Florida Drivers FreeRateReport.com

RE: LGWU ?

Hubbard, Gary Today at 3:21 PM
To lwjd777@yahoo.com, Bullert, Bruce

Jack,

We calibrate the water meters internally at no additional cost to our customers. Meter calibrations normally occur in January of each year.

Should you need additional information or further clarification on this matter, just let me know.

Thanks,
Gary Hubbard

.....
.....

Gary M. Hubbard, P.E.
Utilities Operations Manager
Charlotte County Utilities
25550 Harbor View Rd
Port Charlotte FL 33980
Office: 941.764.4558
Cell: 941.456.0040
Fax: 941.764.4315
gary.hubbard@charlottefl.com

<http://www.charlottecountyfl.com>
"To Exceed Expectations in the Delivery of Public Services"

For more information go to CharlotteCountyFl.com and select the [Water & Sewer](#) from the Popular Links list.

From: Bullert, Bruce
Sent: Friday, May 09, 2014 5:15 PM
To: Hubbard, Gary
Subject: FW: LGWU ?

Gary,

Please respond to Jack.

Thanks, Bruce

From: Jack Boyer [<mailto:lwjd777@yahoo.com>]
Sent: Friday, May 09, 2014 10:46 AM
To: Bullert, Bruce
Subject: LGWU ?

Hi Bruce, jack with LGWU here. I am trying to answer some of the FPSC questions in relation to our bulk water agreement. Looking for a budget number for our annual Calibration fee? thanks jack

The information contained in this email message may be privileged,

Sponsored



Instant Checkmate
New Site Grants Access to
Anyone's Public Record

by The Daily Beast
via Flickr

14

Little Gasparilla Water Utility, Inc.
Docket No. 130265-WU
Friedman, Friedman & Long, P.A.

Actual Fees and Costs through April, 2014 (Invoices Attached) \$ 1,269.61

Estimate to complete rate case through PAA Order

<u>Hours</u>	<u>Description</u>
4.5 hrs	Respond to formal and informal data requests from Staff
7.5 hrs	Prepare for and attend customer meeting; Discuss customer meeting with client and consultant; Discuss customer meeting with Staff, including responding to formal and informal inquiries.
5.0 hrs	Review Preliminary Staff Report and conference with client concerning same; Research and draft response to preliminary Staff Report.
2.5 hrs	Review Staff recommendation; Conference with client and consultants regarding recommendation; Conference with Staff regarding recommendation.
10.0 hrs	Prepare for and attend Agenda conference, discuss Agenda with client.
1.0 hrs	Review PAA Order; conference with client regarding PAA Order.
3.0 hrs	Prepare revised tariff sheets, obtain Staff approval of tariffs; Draft final customer notice, obtain Staff approval; Coordinate mailing of customer notices and implementation of tariffs.
33.5 hrs @ \$350/hr	
TOTAL	\$11,725.00 total estimated fees

Estimate of costs to complete:

\$ 1,000.00 Attend Agenda Conference & Customer Meeting, travel/meals/hotel
 \$ 20.00 Estimated photocopier costs
\$ 20.00 Estimated courier costs
 \$ 1,040.00 TOTAL

TOTAL ACTUAL AND ESTIMATED LEGAL FEES AND COSTS: \$14,034.61

Audrey (Book Keeper 50hr @ 23⁰⁰ = 1,150.⁰⁰

\$15,184.61

1,150.00
↑
Audrey
Attorney
to
Data

1,150.00

259.7 +
2,111.9 +
755.0 +
50.6 +
304.32 *

Attorney

Travel

50 hrs @ 23.00
\$1150⁰⁰

14

LAW OFFICES
SUNDSTROM, FRIEDMAN & FUMERO, LLP
2548 BLAIRSTONE PINES DR
TALLAHASSEE, FLORIDA 32301

F.E.I.# 59-2783536

(850) 877-6555

PLEASE REFER TO INVOICE NUMBER
WHEN REMITTING

LITTLE GASPARILLA WATER UTILITY, INC
C/O JOHN R BOYER
P O BOX 5145
GROVE CITY, FL 34224

JULY 10, 2013
INVOICE # 50654
FILE # 35019-00001
PAGE 1

MATTER: ORIGINAL CERTIFICATE

ACCOUNTS RECEIVABLE BALANCE FORWARD \$.00

6/10/13 MSF DRAFT NOTICE OF FILING AFFIDAVIT AND CUSTOMER .50 175.00
NOTICE; LETTER TO MS. RICE; LETTER TO MS. ROBERTS
AT PSC

TOTAL HOURS .50

PROFESSIONAL FEES \$ 175.00

MARTIN S FRIEDMAN .50 175.00

TOTAL COSTS ADVANCED \$.00

TOTAL STATEMENT \$ 175.00

TOTAL DUE ON ACCOUNT \$ 175.00
=====

86.00

261.00

LAW OFFICES
SUNDSTROM, FRIEDMAN & FUMERO, LLP

2548 BLAIRSTONE PINES DR
TALLAHASSEE, FLORIDA 32301

F.E.I.# 59-2783536

(850) 877-6555

PLEASE REFER TO INVOICE NUMBER
WHEN REMITTING

LITTLE GASPARILLA WATER UTILITY, INC
C/O JOHN R BOYER
P O BOX 5145
GROVE CITY, FL 34224

JULY 10, 2013
INVOICE # 50655
FILE # 35019-00005

MATTER: RECERTIFICATION AT PSC

CURRENT INVOICE SUMMARY

SUMMARY OF CHARGES RENDERED ON THIS INVOICE:

CURRENT FEES: \$ 70.00

CURRENT COSTS: \$ 16.00

TOTAL CHARGES FOR THIS INVOICE: \$ 86.00

OUTSTANDING ACCOUNTS RECEIVABLE: \$ 2,001.66

TOTAL AMOUNT DUE THIS MATTER: ~~\$ 2,087.66~~

due

p.d.

LAW OFFICES
SUNDSTROM, FRIEDMAN & FUMERO, LLP

2548 BLAIRSTONE PINES DR
TALLAHASSEE, FLORIDA 32301

F.E.I.# 59-2783536

(850) 877-6555

PLEASE REFER TO INVOICE NUMBER
WHEN REMITTING

LITTLE GASPARILLA WATER UTILITY, INC
C/O JOHN R BOYER
P O BOX 5145
GROVE CITY, FL 34224

JUNE 11, 2013
INVOICE # 50445
FILE # 35019-00005
PAGE 1

MATTER: RECERTIFICATION AT PSC

ACCOUNTS RECEIVABLE BALANCE FORWARD \$.00

4/04/13 MSF	TELEPHONE CONFERENCE WITH MS. DANIEL AND MS. ROBERTS WHO TELEPHONED WHILE PREPARING STAFF RECOMMENDATION;	.20	70.00
4/13/13 MSF	REVIEW STAFF RECOMMENDATION AND LETTER TO CLIENT CONCERNING SAME	.20	70.00
4/24/13 MSF	TRAVEL TO TALLAHASSEE FOR PSC AGENDA (SHARED WITH TWO OTHER CLIENTS)	1.30	455.00
4/25/13 MSF	PREPARE FOR AND ATTEND PUBLIC SERVICE COMMISSION AGENDA AND REPORT OUTCOME TO CLIENT AND RETURN TO CENTRAL FLORIDA (SPLIT WITH TWO OTHER CLIENTS)	1.70	595.00
4/29/13 MSF	REVIEW PSC ORDER GRANTING WATER CERTIFICATE AND LETTER TO MR. BOYER CONCERNING SAME	.10	35.00
5/23/13 MSF	TELEPHONE CONFERENCE WITH MS. ROBERTS OF PSC WHO TELEPHONED REGARDING FINALIZING TARIFF AND LETTER TO MR. BOYER CONCERNING SAME	.20	70.00
5/28/13 MSF	REVIEW CORRESPONDENCE FROM MR. BOYER AND LETTER TO MS. ROBERTS AT PSC	.10	35.00
5/28/13 MSF	CORRESPONDENCE FROM MS. ROBERTS AT PSC; DRAFT CUSTOMER NOTICE AND RESEARCH AND DRAFT LETTER TO MS. ROBERTS CONCERNING SAME	.70	245.00
5/29/13 MSF	FOLLOW-UP CORRESPONDENCE WITH MS. ROBERTS AT PSC REGARDING CUSTOMER NOTICE AND LETTER TO MR. BOYER CONCERNING SAME	.20	70.00
5/30/13 MSF	LETTER FROM MR. BOYER; TELEPHONE CONFERENCE WITH AND LETTER TO MS. RICE; DRAFT AFFIDAVIT OF MAILING; LETTER TO MS. ROBERTS AT PSC	.50	175.00
	TOTAL HOURS	5.20	

PROFESSIONAL FEES \$ 1,820.00

LAW OFFICES
SUNDSTROM, FRIEDMAN & FUMERO, LLP

2548 BLAIRSTONE PINES DR
TALLAHASSEE, FLORIDA 32301

F.E.I.# 59-2783536

(850) 877-6555

PLEASE REFER TO INVOICE NUMBER
WHEN REMITTING

LITTLE GASPARILLA WATER UTILITY, INC
C/O JOHN R BOYER
P O BOX 5145
GROVE CITY, FL 34224

MARCH 11, 2013
INVOICE # 49726
FILE # 35019-00005
PAGE 1

MATTER: RECERTIFICATION AT PSC

ACCOUNTS RECEIVABLE BALANCE FORWARD \$.00

2/18/13 MSF	BEGIN RESEARCH AND DRAFT RECERTIFICATION TO PSC AND LETTER TO MR. BOYER CONCERNING SAME	1.00	350.00
2/19/13 MSF	CORRESPONDENCE WITH MR. BOYER; FINALIZE RECERTIFICATION APPLICATION	.20	70.00
2/22/13 MSF	FINALIZE APPLICATION, TARIFF AND DOCUMENTATION; LETTER TO PSC CLERK	.90	315.00
	TOTAL HOURS	2.10	

PROFESSIONAL FEES \$ 735.00

MARTIN S FRIEDMAN 2.10 735.00

atty total line 2.10 \$ 735.00

TOTAL COSTS ADVANCED \$.00

TOTAL STATEMENT -----
\$ 735.00

TOTAL DUE ON ACCOUNT
=====

Please Pay 

LAW OFFICES
SUNDSTROM, FRIEDMAN & FUMERO, LLP

2548 BLAIRSTONE PINES DR
TALLAHASSEE, FLORIDA 32301

F.E.I.# 59-2783536

(850) 877-6555

PLEASE REFER TO INVOICE NUMBER
WHEN REMITTING

LITTLE GASPARILLA WATER UTILITY, INC
C/O JOHN R BOYER
P O BOX 5145
GROVE CITY, FL 34224

APRIL 10, 2013
INVOICE # 49938
FILE # 35019-00005
PAGE 1

MATTER: RECERTIFICATION AT PSC

ACCOUNTS RECEIVABLE BALANCE FORWARD

\$ 735.00 *pd.*

3/18/13 MSF	REVIEW AND RESPOND TO CORRESPONDENCE FROM MR. REIGER AT THE PSC;	.10	35.00
3/20/13 MSF	CORRESPONDENCE MR. BOYER; REVIEW SYSTEM MAP AND DRAFT LETTER TO PSC CLERK	.40	140.00
3/27/13 MSF	TELEPHONE CONFERENCE WITH MS. ROBERTS OF PSC WHO TELEPHONED REGARDING SERVICE CHARGES; LETTER TO MR. BOYER CONCERNING SAME;	.30	105.00
TOTAL HOURS		.80	

PROFESSIONAL FEES

\$ 280.00

MARTIN S FRIEDMAN

.80

280.00

atty total line

.80

\$ 280.00

FEDERAL EXPRESS
PHOTOCOPIES

25.66

1.00

TOTAL COSTS ADVANCED

\$ 26.66

TOTAL STATEMENT

\$ 306.66

14

LAW OFFICES
SUNDSTROM, FRIEDMAN & FUMERO, LLP

2548 BLAIRSTONE PINES DR
TALLAHASSEE, FLORIDA 32301

F.E.I.# 59-2783536

(850) 877-6555

PLEASE REFER TO INVOICE NUMBER
WHEN REMITTING

LITTLE GASPARILLA WATER UTILITY, INC
C/O JOHN R BOYER
P O BOX 5145
GROVE CITY, FL 34224

FEBRUARY 11, 2014
INVOICE # 52051
FILE # 35019-00002
PAGE 1

MATTER: MISCELLANEOUS ADVICE

ACCOUNTS RECEIVABLE BALANCE FORWARD \$.00

1/02/14 MSF	REVIEW AND COMMENT UPON COUNTY'S COMMENTS TO INTERCONNECT AGREEMENT; TELEPHONE CONFERENCE WITH MR. BOYER CONCERNING SAME; LETTER TO ATTORNEY BURTON;	.90	315.00
1/06/14 MSF	TELEPHONE CONFERENCE WITH ATTORNEY BURTON REGARDING CHANGES TO BULK SERVICE AGREEMENT AND LETTER TO MR. BOYER CONCERNING SAME;	.40	140.00
1/16/14 MSF	REVIEW MOST RECENT DRAFT OF INTERCONNECT AGREEMENT AND LETTER TO MR. BOYER CONCERNING SAME; TELEPHONE CONFERENCE WITH MR. BOYER WHO TELEPHONED AND LETTER TO ATTORNEY BURTON;	.40	140.00

TOTAL HOURS 1.70

PROFESSIONAL FEES \$ 595.00

MARTIN S FRIEDMAN 1.70 595.00

TOTAL COSTS ADVANCED \$.00

TOTAL STATEMENT \$ 595.00

Friedman, Friedman & Long, P.A.

766 N. Sun Drive
Suite 4030
Lake Mary, FL 32746

F.E.I.: 46-4480334

407-830-6331

PLEASE REFER TO INVOICE NUMBER
WHEN REMITTING

Little Gasparilla Water Utility, Inc.
Post Office Box 5145
Grove City, FL
34224 USA

March 5, 2014

Attention: John Boyer

File #: 35019.04
Inv #: 180

RE: 2013 SARC

Feb-05-14	MSF	Telephone conference with Mr. Boyer who telephoned; draft letter to Mr. Boyer regarding schedule;	0.20	70.00
Feb-17-14	MSF	Telephone Conference with Ms. Bruce of PSC Staff who telephoned; Review Staff's First Data Request; Letter to Mr. Boyer concerning same;	0.20	70.00
Feb-18-14	MSF	Telephone Conference with Mr. Boyer who telephoned; Letter to Ms. Bruce at PSC regarding data request responses;	0.10	35.00

Totals 0.50 \$175.00

Total Fee & Disbursements \$175.00

Balance Now Due \$175.00

Friedman, Friedman & Long, P.A.

766 N. Sun Drive
Suite 4030
Lake Mary, FL 32746

F.E.I.: 46-4480334

407-830-6331

PLEASE REFER TO INVOICE NUMBER
WHEN REMITTING

Little Gasparilla Water Utility, Inc.
Post Office Box 5145
Grove City, FL
34224 USA

March 31, 2014

Attention: Jack Boyer

File #: 35019.04

Inv #: 371

RE: 2013 SARC

Mar-03-14	MSF	Research and draft response to Staff's First data request; Review Audit Report and several telephone conference with Mr. Boyer concerning same;	1.40	490.00
Mar-08-14	MSF	Review and revise Mr. Boyer's response to Audit Report	0.20	70.00
	Totals		1.60	\$560.00

DISBURSEMENTS

Mar-25-14	FedEx		41.36	
	Totals			\$41.36

Total Fee & Disbursements	\$601.36
Previous Balance	175.00
Previous Payments	175.00
Balance Now Due	\$601.36

LAW OFFICES
SUNDSTROM, FRIEDMAN & FUMERO, LLP

2548 BLAIRSTONE PINES DR
TALLAHASSEE, FLORIDA 32301

F.E.I.# 59-2783536

(850) 877-6555

PLEASE REFER TO INVOICE NUMBER
WHEN REMITTING

LITTLE GASPARILLA WATER UTILITY, INC
C/O JOHN R BOYER
P O BOX 5145
GROVE CITY, FL 34224

JANUARY 10, 2014
INVOICE # 51930
FILE # 35019-00004
PAGE 1

MATTER: 2013 SARC

ACCOUNTS RECEIVABLE BALANCE FORWARD \$ 210.00

12/04/13 MSF	PREPARE FOR AND PARTICIPATE IN CONFERENCE CALL WITH PSC STAFF; TELEPHONE CONFERENCE WITH MR. BOYER	.40	140.00
12/09/13 MSF	RESEARCH AND DRAFT LETTER TO COUNTY ADMINISTRATOR	.20	70.00
	TOTAL HOURS	.60	

PROFESSIONAL FEES \$ 210.00

MARTIN S FRIEDMAN .60 210.00

PHOTOCOPIES 2.25

TOTAL COSTS ADVANCED \$ 2.25

TOTAL STATEMENT -----
\$ 212.25

TOTAL DUE ON ACCOUNT
=====

LAW OFFICES
SUNDSTROM, FRIEDMAN & FUMERO, LLP

2548 BLAIRSTONE PINES DR
TALLAHASSEE, FLORIDA 32301

F.E.I.# 59-2783536

(850) 877-6555

PLEASE REFER TO INVOICE NUMBER
WHEN REMITTING

LITTLE GASPARILLA WATER UTILITY, INC
C/O JOHN R BOYER
P O BOX 5145
GROVE CITY, FL 34224

DECEMBER 11, 2013
INVOICE # 51660
FILE # 35019-00002
PAGE 1

MATTER: MISCELLANEOUS ADVICE

ACCOUNTS RECEIVABLE BALANCE FORWARD \$.00

11/05/13 MSF	REVIEW AND COMMENT UPON INTERCONNECT AGREEMENT WITH CCU; FOLLOW-UP CORRESPONDENCE WITH MR. BOYER; TELEPHONE CONFERENCE WITH MR. BOYER AND REVISE INTERCONNECT AGREEMENT ACCORDINGLY;	1.40	490.00
11/06/13 MSF	CORRESPONDENCE WITH MR. BOYER AND DRAFT LETTER TO ATTORNEY BURTON AT CHARLOTTE COUNTY; REVIEW RESPONSE	.40	140.00
	TOTAL HOURS	1.80	

PROFESSIONAL FEES \$ 630.00

MARTIN S FRIEDMAN 1.80 630.00

TOTAL COSTS ADVANCED \$.00

TOTAL STATEMENT \$ 630.00

TOTAL DUE ON ACCOUNT \$ 630.00

630
210
840

LAW OFFICES
SUNDSTROM, FRIEDMAN & FUMERO, LLP

2548 BLAIRSTONE PINES DR
TALLAHASSEE, FLORIDA 32301

F.E.I.# 59-2783536

(850) 877-6555

PLEASE REFER TO INVOICE NUMBER
WHEN REMITTING

LITTLE GASPARILLA WATER UTILITY, INC
C/O JOHN R BOYER
P O BOX 5145
GROVE CITY, FL 34224

DECEMBER 11, 2013
INVOICE # 51661
FILE # 35019-00004
PAGE 1

MATTER: 2013 SARC

ACCOUNTS RECEIVABLE BALANCE FORWARD \$.00

11/19/13 MSF TELEPHONE CONFERENCE WITH MR. BOYER WHO .60 210.00
TELEPHONED; LETTER TO PSC STAFF; TELEPHONE
CONFERENCE WITH MR. MOURING WHO TELEPHONED;

TOTAL HOURS .60

PROFESSIONAL FEES \$ 210.00

MARTIN S FRIEDMAN .60 210.00

TOTAL COSTS ADVANCED \$.00

TOTAL STATEMENT -----
\$ 210.00

TOTAL DUE ON ACCOUNT \$ 210.00
=====

LAW OFFICES
ROSE, SUNDBSTROM & BENTLEY, LLP

2548 BLAIRSTONE PINES DR
 TALLAHASSEE, FLORIDA 32301

F.E.I.# 59-2783536

(850) 877-6555

PLEASE REFER TO INVOICE NUMBER
 WHEN REMITTING

SUBAQUEOUS, LLC
 DEAN BECKSTEAD
 7092 PLACIDA RD
 CAPE HAZE, FL 33946

MLU

JULY 11, 2011
 INVOICE # 45445
 FILE # 45083-00001
 PAGE 1

MATTER: FORMATION OF LLC

5/26/11 MSF	REVIEW CORRESPONDENCE FROM MR. BOYER REGARDING NEW COMPANY; REVIEW CHARLOTTE COUNTY ORDINANCES; TELEPHONE CONFERENCE WITH MR. BECKSTEAD AND MR. BOYER	.80	272.00
5/27/11 MSF	RESEARCH AND DRAFT LETTER OF UNDERSTANDING AND LETTER TO CLIENTS CONCERNING SAME.	.60	204.00
6/14/11 MSF	FORM LIMITED LIABILITY COMPANY	.30	102.00
6/15/11 MSF	RESEARCH AND DRAFT OPERATING AGREEMENT; DRAFT AMENDMENT TO CHANGE MR. NODEN'S ENTITY	1.40	476.00
6/21/11 MSF	REVIEW MR. UNDERWOOD'S COMMENTS TO OPERATING AGREEMENT AND LETTER TO MR. BECKSTEAD CONCERNING SAME	.30	102.00
6/22/11 MSF	TELEPHONE CONFERENCE WITH MR. UNDERWOOD WHO TELEPHONED; LETTER TO CLIENTS	.30	102.00
6/27/11 MSF	RESEARCH AND DRAFT PROPOSED BULK WATER AGREEMENT	1.20	408.00
6/28/11 MSF	REVISE BULK WATER SERVICE AGREEMENT AND LETTER TO CLIENTS CONCERNING SAME	.90	306.00
	TOTAL HOURS	5.80	

PROFESSIONAL FEES \$ 1,972.00

MARTIN S FRIEDMAN 5.80 1,972.00

Company: _____

5.80 \$ 1,972.00

Acct. #: _____

Total: _____

Approved: *ADB* _____

Posted: _____

Date Pd.: _____

Chk. #: _____

LAW OFFICES
ROSE, SUNDBROM & BENTLEY, LLP

2548 BLAIRSTONE PINES DR
TALLAHASSEE, FLORIDA 32301

F.E.I.# 59-2783536

(850) 877-6555

PLEASE REFER TO INVOICE NUMBER
WHEN REMITTING

SUBAQUEOUS, LLC

Invoice #: 45445

PAGE 2

FILING FEE	125.00
PHOTOCOPIES	1.00
TOTAL COSTS ADVANCED	\$ 126.00

TOTAL STATEMENT	----- \$ 2,098.00 =====
-----------------	-------------------------------



Charlotte County Generators

2112 Jacobs Street Port Charlotte ,FL

941-624-2274

33953

#1600

New Client Application (Residential): Please print legibly in blue or black ink

Full Name:	Little Gasparilla Water Hill	Date of Birth:		Last 4 of SSN	
Billing Address:	P.O. 5159	Service Address:			
City, State, Zip	Grove City FL	City, State, Zip			
Seasonal? Circle one:	YES <input type="radio"/> NO <input checked="" type="radio"/>	please list other service addresses on the back of this form----->			
Alt. Contact Name:	Jack Boyer	Date Range you reside at service address:			
Alt. Contact Phone	941 626 8294				
How did you hear about us?	Gate Code Required for Entry:				
Do you have objections to us servicing your unit if you are not home? (circle one) YES <input type="radio"/> NO <input checked="" type="radio"/>					

Home Phone		Work Phone		Cell Phone	
Best Day & Time of Day to contact (circle):	Mon.	Tues.	Wed.	Thurs.	Fri. / Morning or Afternoon
Email:					
Alt. Email:					

For Office Use Only:

Make/Model:		Size:		Transfer Switch Inside?	
Special Parts, part #'s etc:					
Annual System Inspection & Full Service Including Parts.....	\$189.50	Notes:			
Semi-Annual System Inspection.....	\$100.00				
<i>Seasonal Residents: Annual and Semi-annual Inspections are Recommended to optimize your generators performance.</i>					

Agreement for Service Maintenance:

This scheduled maintenance agreement is between above stated and Charlotte County Generators, LLC for the location(s) listed above. The duration of this agreement is for one (1) year beginning on the date of the first scheduled preventative maintenance. All preventative maintenance work is base on rates for normal business hours Monday through Friday. Labor or parts not covered under this agreement will be subject to our regular existing rate unless otherwise specified. The charge for our full service maintenance includes: Oil, oil filters, spark plugs, fuel filters and the disposal of used oil and filters. PAYMENT IS DUE UPON COMPLETION OF SERVICE/PREVENTATIVE MAINTENANCE.

Authorized Signature: _____

Date: 5-8-14

Charlotte County Generators

5-10-14

Annual Sys Inspection

\$189⁵⁰

170a

LITTLE GASPARILLA WATER UTILITY, INC.

P.O. BOX 5159

GROVE CITY, FLORIDA 34224

941-681-2778

Reference; #7 Billing Flows

We bill quarterly and the report attached is the closest thing we can come up with. Flows will be off by 15 days on both ends. I hope that makes since.

So;

12 month billing usage is 9,684,314

12 month of production 10,291,000

Difference of 607,686

I would attribute the difference to flushing and leaks.



An Easier Read

176

Date: May 6, 2014
Quote #: 00109
Quote Valid For: 90 days

Salesperson	Job	Shipping Method	Shipping Terms	Delivery Date	Payment Terms	Due Date
Cody Champagne	Little Gasparilla	Best Way			Net 30 days	

Qty	Item #	Description	Unit Price	Discount	Line Total
1.00		Blutower Drive-by Evaluation Kit	\$23,414.63		\$ 23,414.63
1.00		On-Site Training and Software Install	\$1,500.00		\$ 1,500.00
Items included in Evaluation Kit					
100.00		5/8 x 3/4 BluMet Meters	n/c		
1.00		Laptop	n/c		
1.00		FasTrackIT Receiver	n/c		
1.00		Blutower RMS Software	n/c		

Total Discount		
	Subtotal \$	24,914.63
	Sales Tax	
	Total \$	24,914.63

Quotation prepared by: _____CodyChampagne_____

This quote does not include shipping or any applicable sales tax.

To accept this quotation, sign here and return: _____

Thank you for your business!

2855 South Pine Ave / Ocala, FL 34471

Evaluation Starter Kit

**IMPROVE CUSTOMER
RELATIONSHIPS**

IMPROVE EFFICIENCY

IMPROVE SAFETY



- 100 Endpoints
- Receiver package with all necessary hardware and software
- Onsite training and software installation
- Technical support after installation

BluTower is offering water utilities an exciting new opportunity to “test drive” AMR without the expense of automating the entire system. Conventional meter reading is a labor-intensive process and BluTower is confident that any utility will see an immediate return on its’ investment, by moving toward automating their system.

BluTower’s Evaluation Starter Kit will be tailored to meet your utilities individual needs with regards to hard to read meters, leak detection and resolving meter reading disputes. We offer a fully integrated register (BluMet) that can retrofit most leading water meter manufactures direct read registers and a wired endpoint (DataSource915)

for use with existing encoded or pulse output registers. Based on the age of the meters in your system, a complete meter change out could be a way to recoup lost revenue from under registering water meters.

Receiver Options:

HandTrackIT® Receiver (Walk-by) – Ideal for small to medium size utilities with less than 4000 endpoints in a condensed urban setting.

FastTrackIT® Receiver (Mobile) – The preferred system for medium to large utilities in either rural or urban settings.



BluMet Water Meter



Features and Benefits

- ⇒ Integral Radio and Water Meter
- ⇒ Quality NSF-61 Bronze Construction
- ⇒ True Encoded Communication for Accurate Bills
- ⇒ Rated to 120°F
- ⇒ Factory Programmed
- ⇒ Works Within BluTower's Walk-by, Drive-by and Fixed Network Systems
- ⇒ Available in 5/8" thru 2" Sizes
- ⇒ Also Available in Turbine and Compound Meters
- ⇒ Meets or Exceeds AWWA C700 Standards
- ⇒ 20 Year Battery Warranty
- ⇒ Durable Strainer Protects Against Damage
- ⇒ Optional Datalogging

Simple

BluMet comes from the factory ready to install. No special FCC Licenses are required so preconstruction time planning is no longer critical. No wiring is required in the field and no configuration programming is required by the installer. By keeping it simple and allowing for a quick installation, BluMet keeps installation and maintenance costs down and ensures a successful installation every time, and time is money.

Affordable

With few moving parts and no wires BluMet is innately inexpensive when compared to conventional meters with conventional registers from which it evolved. Fewer parts, thanks to advanced engineering, results in the best value in the utility/submetering market.

Connector

Tailpieces/meter couplings for installation of meters are available as an option.

Accurate

BluMet utilizes the BluTower positive displacement meter that conforms to AWWA C700 standards and is NSF-61 certified. PD Meters are inherently accurate over a wide flow range and unlike jet-style meters, their accuracy is not susceptible to changes in orientation so vertical installs are not a problem. Its positive displacement design is time-proven for long-term accuracy and dependability, ensuring maximum revenue for many years. The revolutionary LCD display not only shows the meter reading but it also communicates that reading to the integral radio. With the radio and battery mounted internally there is no resident tampering or questionable reads with BluMet!

Flexible

BluMet can be read as either a fixed network, drive-by or walk-by. It uses the same RF protocol as BluTower DataSource 915 Transponders and therefore can coexist on the same network or reading route.

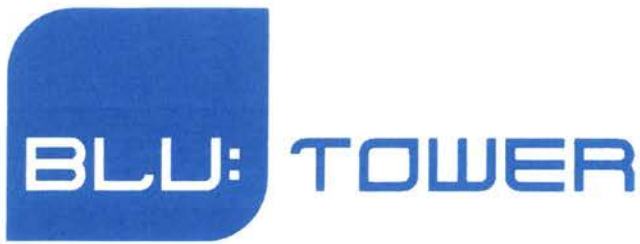

900 Series FastTrackIT[®] Receiver



Features and Benefits

- ⇒ Designed to work in an open systems environment
- ⇒ Fast data acquisition: >200 meters/sec
- ⇒ Operation at posted rate speeds
- ⇒ Readings in excess of 40,000 meters/day
- ⇒ Interfaces to popular billing and route management systems
- ⇒ Compact and easily transferable from one vehicle to another

Application The 900 Series FastTrackIT receiver is the vehicle based data collection device for the BluTower DataSource and 900 Series AMR system. The FastTrackIT is a radio receiver that permits meter readers to quickly retrieve a large number of meter readings from a vehicle driving at posted speed limits.

Operation A FastTrackIT is designed to fit temporarily in the passenger seat of a vehicle. It can be easily installed in the vehicle and removed so that there is no need to dedicate a single vehicle to the reading activity. The reading route file is loaded into the laptop computer before the route is read. At the end of the day the route file, with completed readings, is downloaded to route management or billing system. The receiver protocol is open so it can be integrated with most utilities existing handheld computers and route management software packages.

Accessories A complete FastTrackIT system includes:

- Radio receiver
- Laptop computer
- Data collection software
- Antenna
- Power cable
- Data cable

Standards The system operates in the 902 MHz to 928 MHz ISM band and is FCC Part 15 compliant, which means that no part of the system requires a license for operation. It is also meets the IC RSS210 standards for Industry Canada Specification for Approval of Low Power, License Exempt Radio Communication devices.

Part Numbers	
Description*	Part Number
FastTrackIT Receiver Package	820-100-10
FastTrackIT Antenna Package	310-200-10
FastTrackIT Systems Pkg includes laptop	830-100-10

*Please contact distributor or BluTower for full details of package contents and individual item requests.

OPERATIONAL AND PHYSICAL CHARACTERISTICS

Wireless Specifications	Operates in the 902 MHz to 928 MHz license exempt ISM band
Operating Temperature	-4° F to +122° F (-20° C to +50° C)
Storage Temperature	-40° F to +158° F (-40° C to +70° C)
Operating Voltage	12VDC – FastTrackIT [®] has PSU that is hardened for use in vehicle systems
Power Consumption	3W (Nominal current is 250mA)
Communication protocol	RS-232 (DB9) at 115kbps
Antenna	13 3/4" x 7 1/2" x 2" co-linear antenna with magnetic mount base
Dimensions	10 3/4" x 7 1/2" x 2"
Weight	2 lbs



©2009 BluTower, Inc. All rights reserved. Names, brand names and product names are the property of their respective holder(s). BluTower, Inc. reserves the right to change specifications, packaging, or other product information without notice. This publication could include technical inaccuracies or typographical errors.

BluTower, Inc.
2855 South Pine Ave.
Ocala, FL 34471
Tel: 352-624-8695
Fax: 352-624-8696

Email: infoweb@blutower.com
Web: www.blutower.com



DS900FastTrackIT012714

#19A

1

1 is North & 6 is South



-  6"
-  4"
-  2"
-  3"

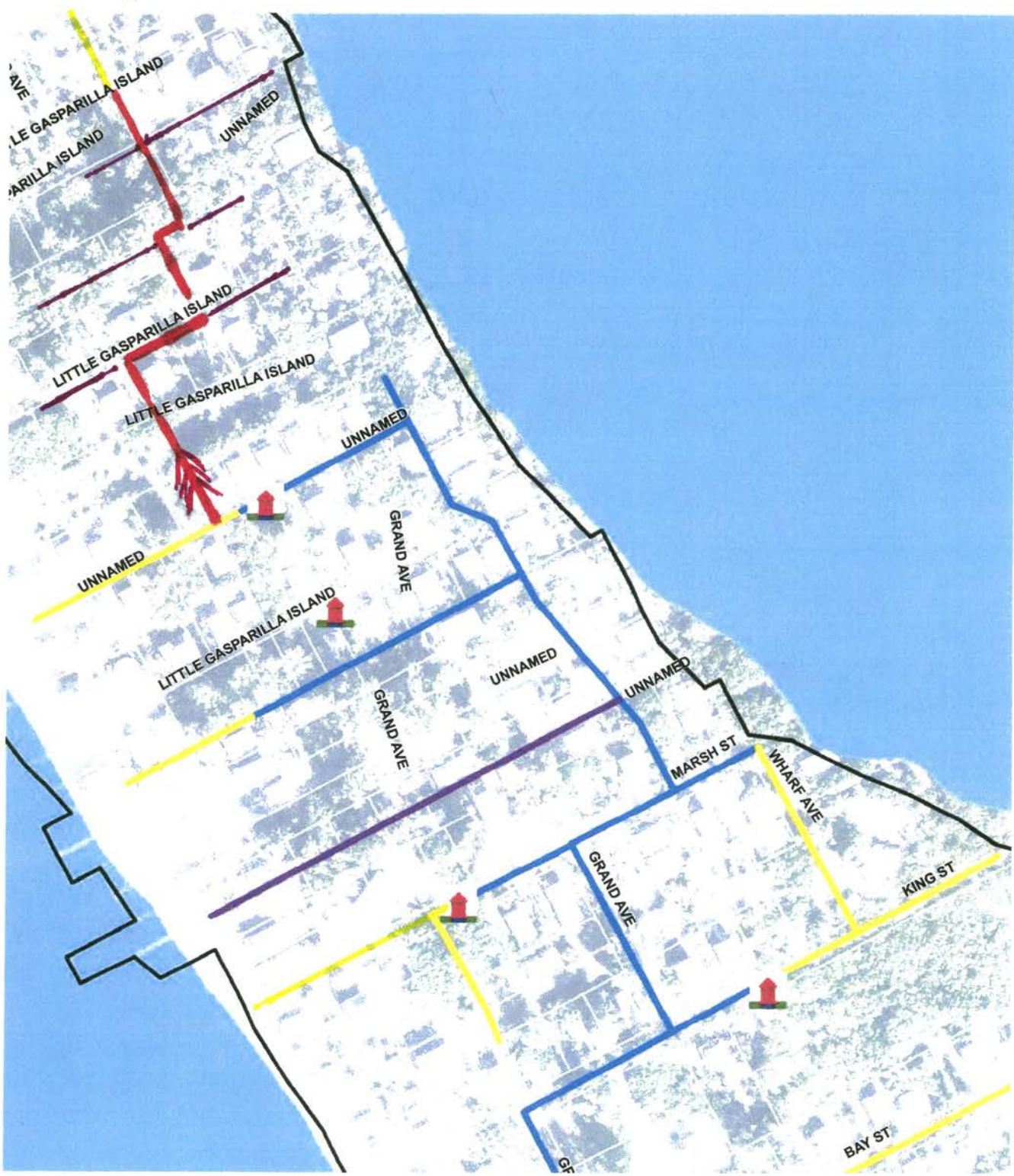

IN PERMITTING W/DEP



Water Plant

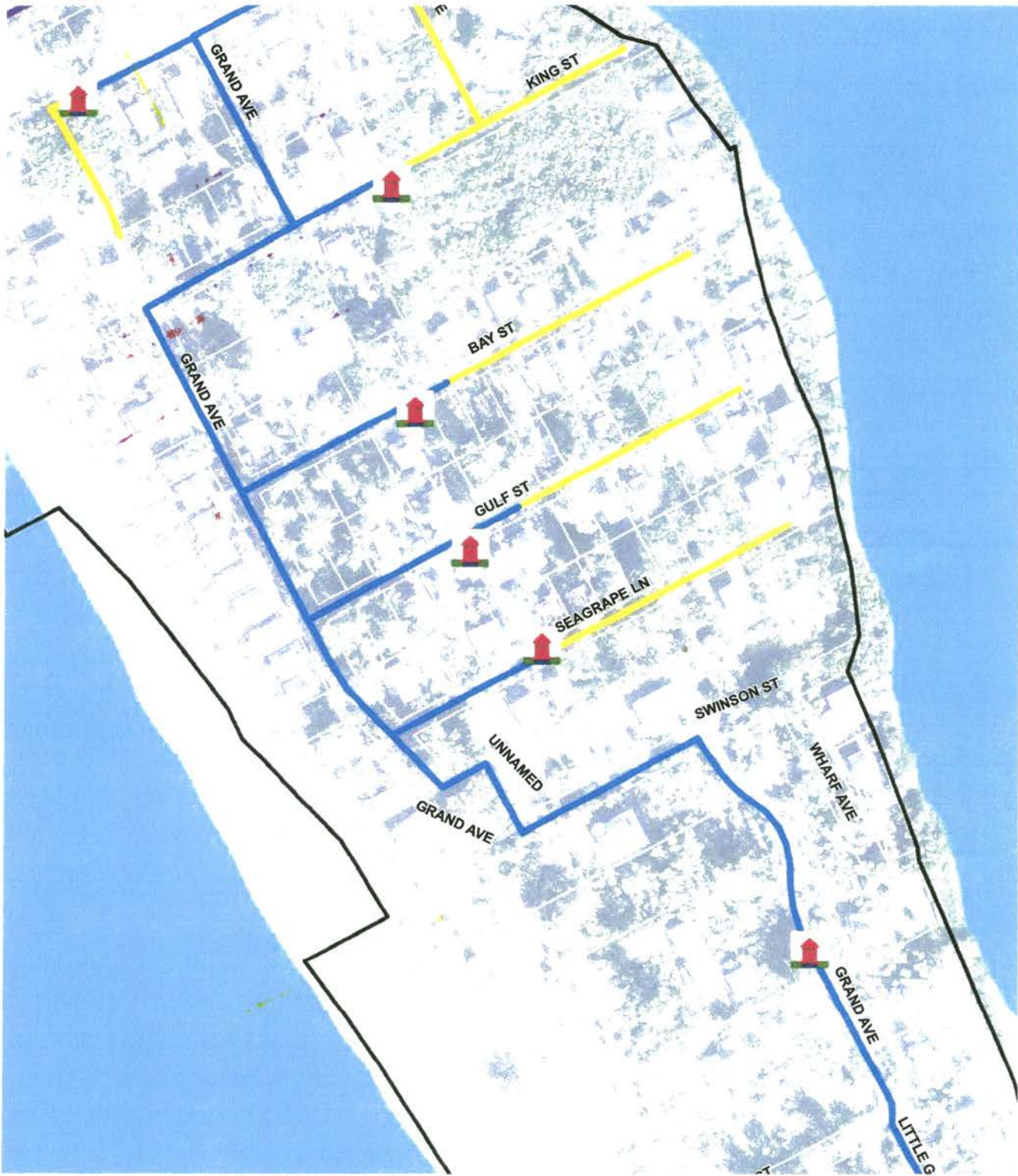

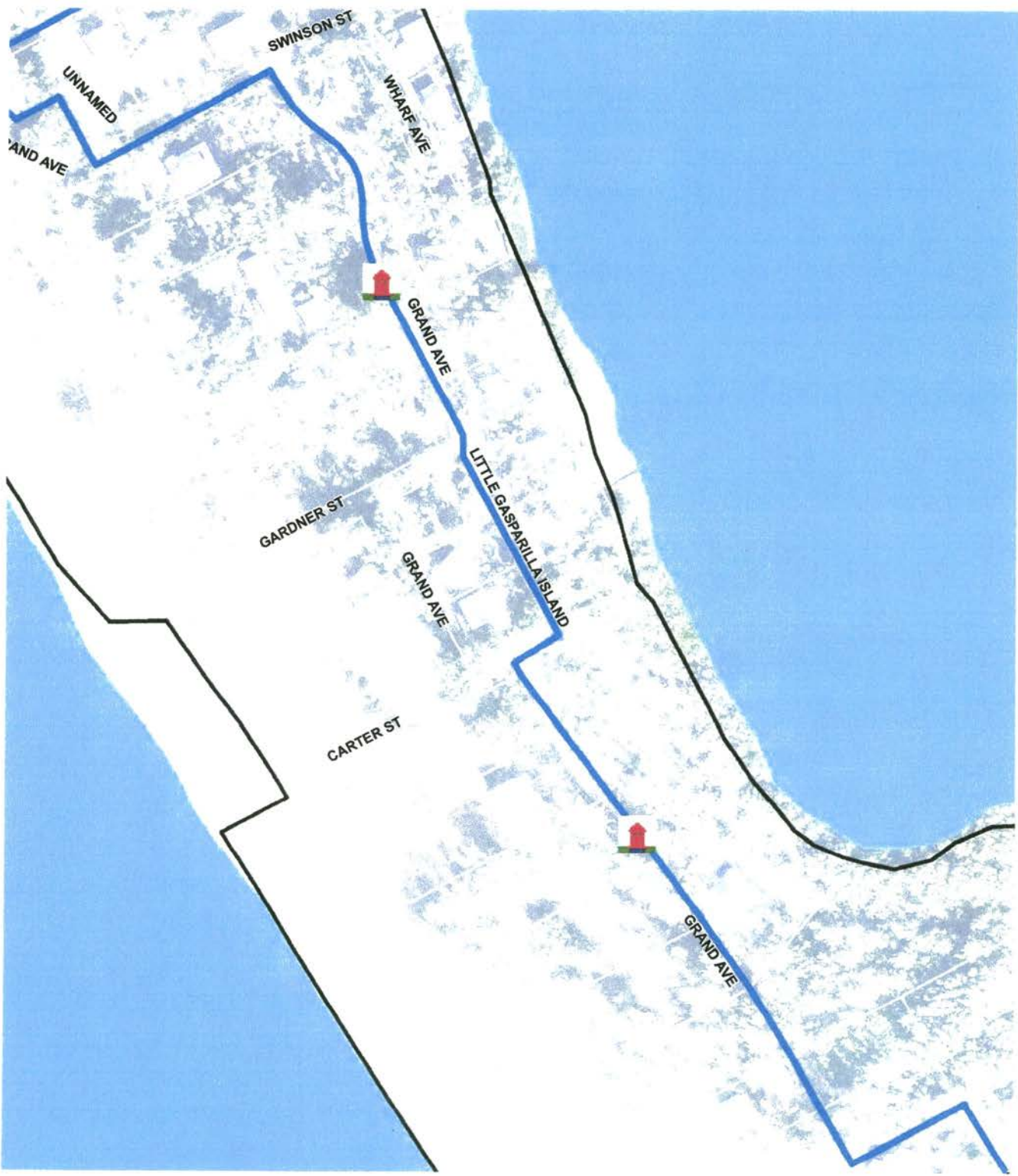

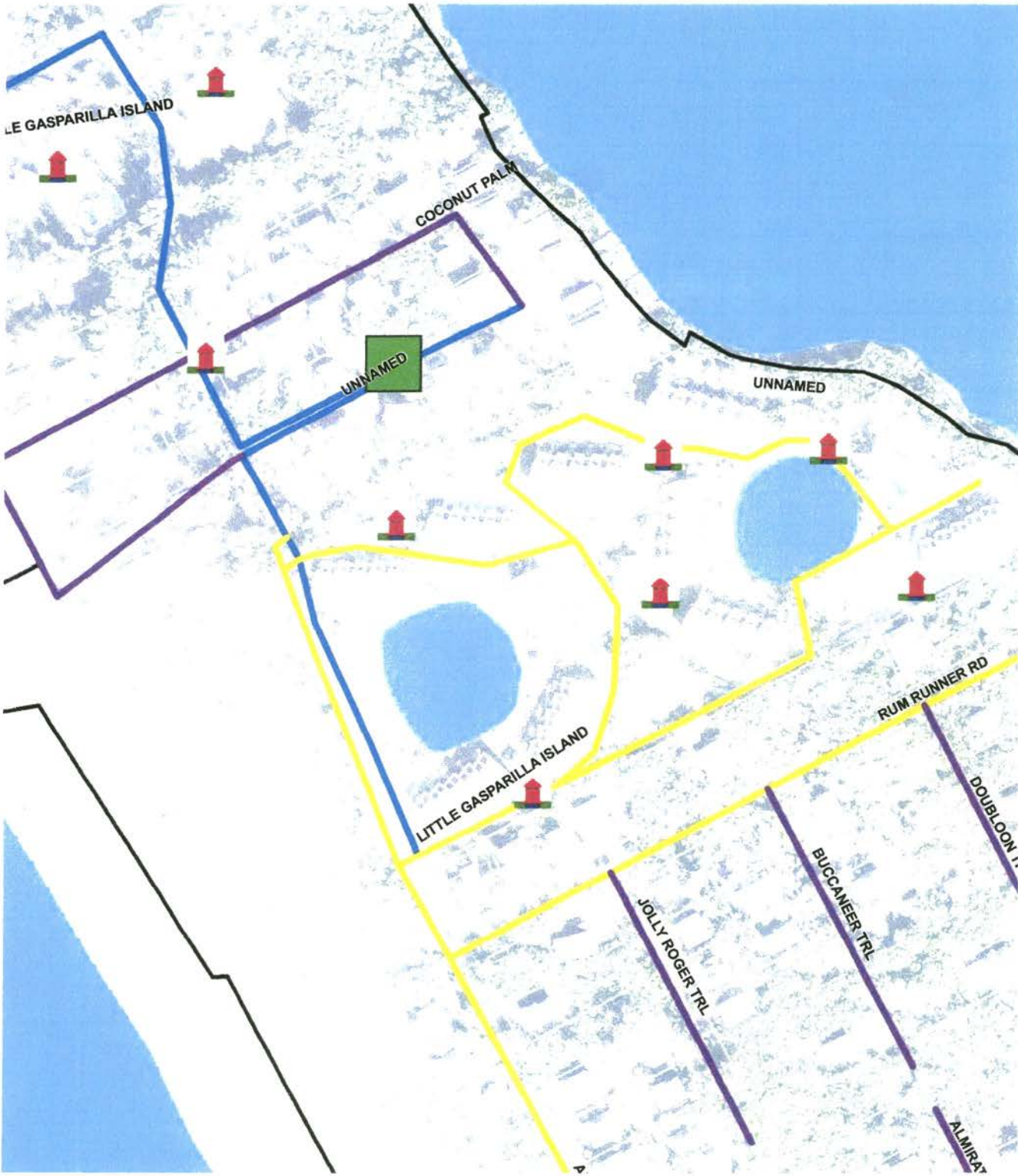

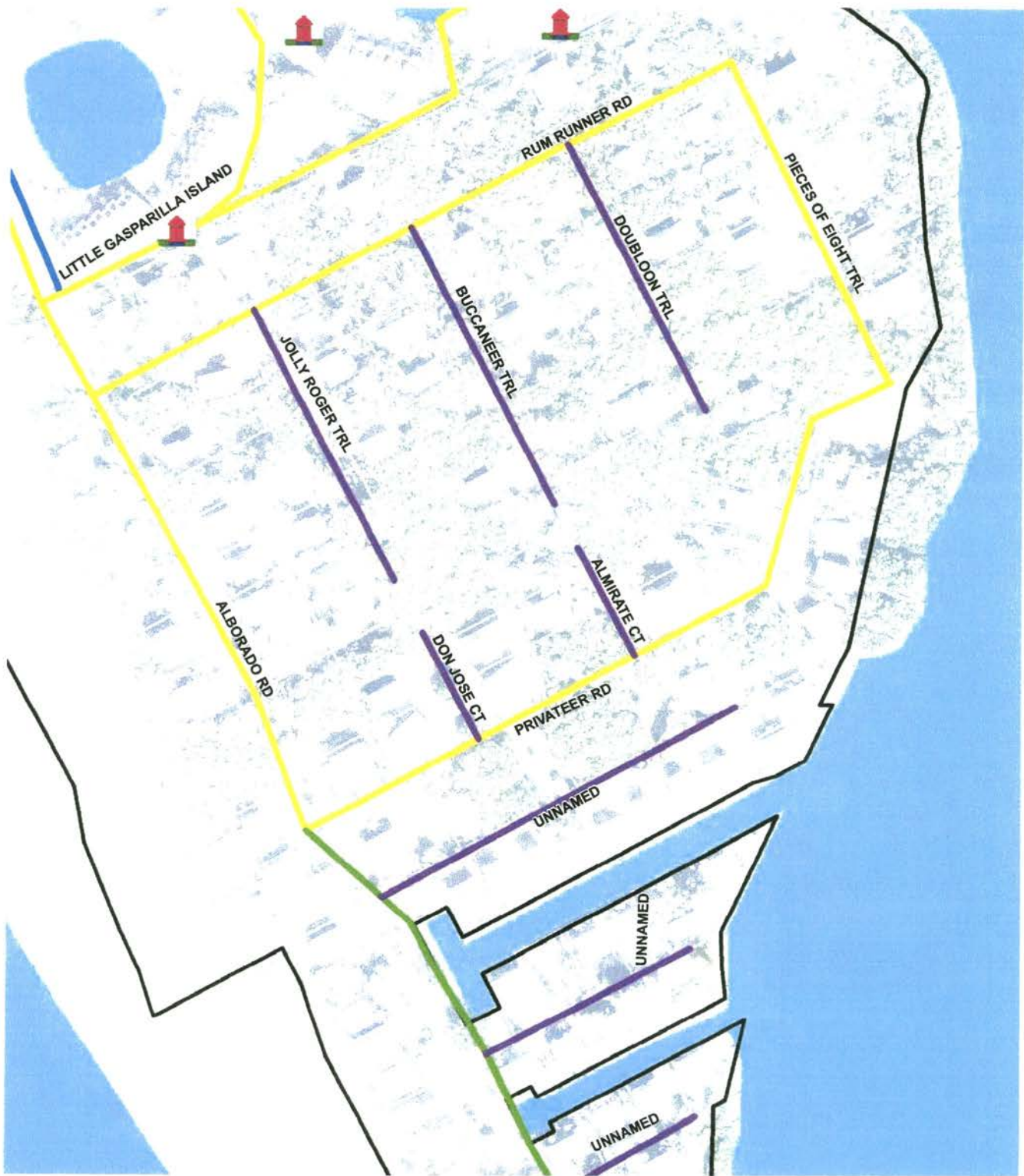

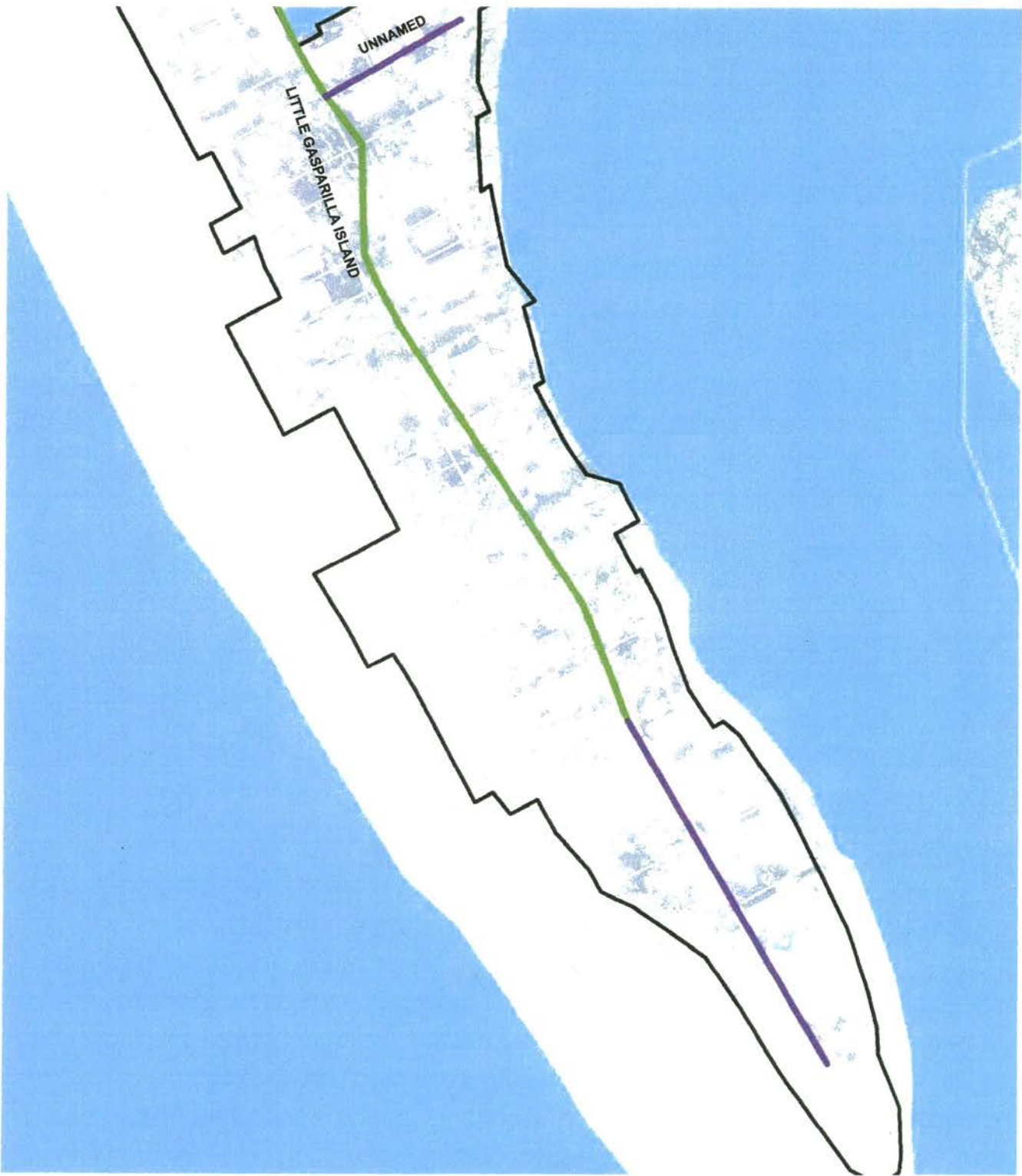

LITTLE GASPARILLA ISLAND

UNNAMED

#21

Home Mail News Sports Finance Weather Games Groups Answers Screen Flickr Mobile | More

Search Mail Search Web Jack



Compose

Actions: Delete, Move, Spam, View, More, Sponsored

- Inbox (2)
- Drafts
- Sent
- Spam (567)
- Trash (8)
- ▼ Folders (17)
 - Accounting appraisals
 - ATT
 - Boat
 - Britt
 - credit
 - Deleted Items (16)
 - e-bay
 - Erin's wedding
 - Farmers Market
 - forms
 - FPL-LGWU
 - HC LLC.
 - Holy Land 2012
 - Insurance
 - Investors
 - Islands
 - KIU
 - Legal
 - LGWU
 - loans
 - Marinas
 - N.C. Property
 - Notes
 - OFF-THE-HOOK
 - O-T-H
 - PAT
 - Pedals Pushers
 - Pictures
 - PSC
 - Rocky Creek
 - Sent Items
 - Synced Messages
 - Taxes (1)
 - Testimonys
 - Wallace
 - YL

- Ame...** Earn up to 30,000 Bonus Miles Towar... **Sponsored**
- ☐ Igpoaju Re: Fw: Little Gasparilla Water Utility 12:15 PM
- ☐ Abrahar RE: Jack Boyer-CCU applicatiojn 11:28 AM
- ☐ **Pandor.** **More music for you** **11:19 AM**
- ☐ Abrahar ★ RE: 565 Green Dolphin Dr 11:03 AM

Overstock Clearance - 7" Tablet PC for only \$59! Nomoreraack.com

They're Here! 2014's Top 10 Balance Transfer Cards Credit Karma

\$0 Down Home Loan for Veterans- See if You Qualify Veterans United

Upgrade Your Home with Quality Laminate Flooring BuildDirect®

How old is your body? RealAge

RE: Jack Boyer-CCU applicatiojn

Abraham Binoy Today at 11:28 AM
To 'Clune, Patricia', 'Jack Boyer'

Dear Patricia,

I need the following :

1. Application number.
2. Any corrections on the notices to be sent out to property owners. Notices have not been mailed yet. See attached.
3. Additional fees. \$500 for the submerged land easement Per section 18-21.008 (1)(a)(8) and \$650 for the water connection per Form 62-555.900(7) have been mailed.

Thank you.

Abraham Binoy, PE
DMK Associate, Inc.

From: Clune, Patricia [mailto:Patricia.Clune@dep.state.fl.us]
Sent: Monday, May 12, 2014 3:15 PM
To: Abraham Binoy
Subject: RE: Jack Boyer-CCU applicatiojn

What are the \$500 and the \$650 checks for? The Easement processing fee is \$619 and I'm not sure what the permit fee is at this time. As far as the drinking water permit goes, that is handled by another section so I have no idea what their permit fees are at this time.

Patricia Clune
Environmental Specialist II

Florida Department of Environmental Protection
Submerged Lands and Environmental Resource Permitting
South District Office
2295 Victoria Avenue, Ste 364
Fort Myers, FL 33902-2549
Email: Patricia.Clune@dep.state.fl.us
Tel. 239.344.5639
Fax 850.412.0590

If you have received an authorization from the ERP program, please click on the survey link (below) to provide us valuable feedback about your experience. [ERP Customer Survey](#)

Additional web resources:

[DEP Home Page](#) [DEP Business Portal](#) [ERP Online Help](#)

From: Abraham Binoy [mailto:abinoy@dmkassoc.com]
Sent: Monday, May 12, 2014 2:40 PM
To: Clune, Patricia
Subject: Jack Boyer-CCU applicatiojn

Dear Patricia,

I am attaching Form F and detail activity statement along with this email, it

Sponsored



Nomoreraack.com
Overstock Clearance - 7" Tablet PC for only \$59!

by MADDIE PHOTOGRAPHY on flickr

24,438.03 /
 11 3,951.23
 12 13,998.30
 13 6,498.50
 14 27,837.05
 DEP = 1,751.00
 Total to D 53,425.06
 51,711.00
 53,425.06
 105,125.06

DEP ✓ 5
 18
 2
 4
 3
 5
 7
 7
 5
 52,85

Future # 22

Home Mail News Sports Finance Weather Games Groups Answers Screen Flickr Mobile | More

Search Mail Search Web

Jack



Compose

- Inbox (5)
- Drafts
- Sent
- Spam (551)
- Trash
- ▼ Folders (17)
 - Accounting
 - appraisals
 - ATT
 - Boat
 - Britt
 - credit
 - Deleted Items (16)
 - e-bay
 - Erin's wedding
 - Farmers Market
 - forms
 - FPL-LGWU
 - HC LLC.
 - Holy Land 2012
 - Insurance
 - Investors
 - Islands
 - KIU
 - Legal
 - LGWU
 - loans
 - Marinas
 - N.C. Property
 - Notes
 - OFF-THE-HOOK
 - O-T-H
 - PAT
 - Pedals Pushers
 - Pictures
 - PSC
 - Rocky Creek
 - Sent Items
 - Synced Messages
 - Taxes (1)
 - Testimonys
 - Wallace
 - YL

☰ ⏪ ⏩ 🗑️ Delete 📁 Move ⋮ More ⏴ View ☀️ Sponsored

- | Mac... | Tired of Boring Games? | Sponsored |
|-----------------------------------|---|-----------|
| <input type="checkbox"/> Jack Boy | Fw: aggrement | 10:03 AM |
| <input type="checkbox"/> Charlott | Re: Estimate 158 from Charlotte County Gr | 9:54 AM |
| <input type="checkbox"/> dianedic | RSVP | 8:32 AM |
| <input type="checkbox"/> Leigh O | Re: Fill | May 11 |

Better than Brow Pencils
DermStore

Find Your High School Yearbook
Classmates.com

How Old is Your Body?
RealAge

Ready for a Vacation?
Compare Hotels
trivago

ITT Tech's School of Information Technology
ITT Technical Institute

Fw: aggrement

Jack Boyer
To Jack Boyer

Today at 10:03 AM

----- Forwarded Message -----

From: Karl W. Kokomoor PE <kkokomoor@dmkassoc.com>
 To: 'Jack Boyer' <lwjd777@yahoo.com>
 Cc: 'Warren McLeod' <wmcleod@dmkassoc.com>; Kreg Maheu <KMaheu@dmkassoc.com>; 'Abe Binoy' <abinoy@dmkassoc.com>
 Sent: Monday, May 12, 2014 5:02 PM
 Subject: RE: aggrement

Jack,
 I have attached a signed copy of our agreement. To date, we have invoiced \$27,837.05. \$25,454.55 is outstanding and due. We are approximately:

1. 90% complete with Task 1, Building and Pipeline Design
2. 60% complete with Task 2, Permitting. (we have not included any of the pump house modifications in the DEP Permit)
3. 60% complete with Task 3, Land Lease

18
8
4
<30 k>

If you can get up payment on what is owed, it would be appreciated.

There is no budget for providing services during construction, certification of completion to agencies, certification to the utility, preparation of easements, staking of the waterline over the north, staking for guidance of the subaqueous.

These services will be supplied hourly and depend upon when construction takes place and how long it will take to complete. Some very rough budget numbers are:

1. Staking the north pipe 1800 feet over land, 3 crew days, \$3,600
2. Providing as builts of the north pipe, 3 crew days, \$3,600
3. Staking the route of the subaqueous pipe. This will be in the bid numbers by the contractor. No budget included.
4. Services during construction, 2 engineer visits to site per week. 8 per month, \$4,000 per month of construction.
5. Preparation of easements adjacent to lots. Estimate of 30 easements necessary at \$250 each
6. As builts for the subaqueous line: wire guided positioning provided by contractor, contractor markups with surveyors rough staking, transferred straight to engineers as built. No final survey locations by PSM. Survey locates on landward portions, 1 crew day plus drafting and engineering verification; \$5,000

3,600
3,600
2,000 (2 w.k.)
7,500

5,000

\$21,700
\$51,700

These are all estimates only. They do not anticipate problems from DEP Coastal Systems or the Army COE or CCU for as builts and verification.

Sponsored



CompareCards.com
Credit Cards Now Offering 0% APR for 18 Months.



22 13-0209
Backup

ENGINEERS SURVEYORS PLANNERS

435 Commercial Court, Suite 200, Venice, FL 34292 Phone (941) 626-8294 Fax (941) 626-8295

435 S. Venice Road, Venice, FL 34292 Phone (941) 626-8294 Fax (941) 626-8295

DATE: February 19, 2013

CLIENT: Little Gasparilla Island Water Utility
Mr. Jack Boyer
PO Box 5145
Grove City, FL 34224

RE: Bulk Water from CCU and LGI
Water Distribution System Extension

Ph: (941) 626-8294

This Proposal/Agreement is between Little Gasparilla Island Water Utility/Jack Boyer and DMK Associates, Inc. of 435 Commercial Court, Suite 200, Venice, FL 34292. The Description of the land on which these services will be performed is, Little Gasparilla Island and the ICW.

DMK Associates (DMK) shall provide engineering, survey and permitting services required to construct a 6-inch potable water/fire service line from a CCU supplied water meter near Cape Haze, directionally bored under the ICW to connect with existing LGI facilities on Little Gasparilla Island. DMK's design and permitting efforts will include the demolition and replacement of the R/O plant's deteriorating wood, pump house building and the extension of their water distribution system to the north end of Little Gasparilla Island.

DMK's services shall include, but likely not be limited to:

Task 1 - Engineering Services

During the Engineering phase, DMK shall provide:

- a. Drafting services for the demolition and reconstruction of the wood pump house building at the LGI water plant from a sketch provided by the Client.
- b. Engineering and design services for a 3,300 linear feet of a directionally bored 6-inch water main under the ICW from Cape Haze to LGI to connect existing CCU and LGI water facilities.
- c. Engineering and design services for 1,800 linear feet of a 4-inch extension to the existing water distribution system to the north end of Little Gasparilla Island.

Fee: \$18,000.00 @ 90% Balance of \$1,800

Task 2 - Permitting Services

DMK shall combine the pump house replacement, directional bore under the ICW and the water distribution extension into an Environmental Resource and Water Main Extension Permit submittal to the Florida Department of Environmental Protection. Our permit submittal will be compliant with Rule 62-555.330, F.A.C. The Army Corp of Engineers and FDEP's Bureau of Beach and Coastal Systems will also be involved in the FDEP permitting process.

Fee: \$20,000.00 @ 60% \$12,000

Task 3 - Sovereign Submerged Land Lease

Once FDEP conceptually approves the directional bore alignment under the ICW, DMK shall prepare a Land Lease Easement across Gasparilla Sound, from approximately Lot 1, Block U, Cape Haze subdivision on Green Dolphin Drive to King Street on Little Gasparilla Island. The proposed route will cross privately owned submerged lands by Cape Haze Corporation and West Coast Inland Navigation District which may require separate easements for each, not included in this proposal.

Fee: ~~\$4,500.00~~ \$10k @ 60% \$4,000

Client: Family Gasparilla Island Water Utility Mr. Jack Bowen

Date: February 19, 2013

NOTE: No structural engineering, environmental, bathymetric survey or geotechnical work is being proposed or included in the Fee Proposal.

DMK Associates, Incorporated agrees to provide the above services under an: Hourly Fee Fixed Fee
 Estimated Fee for the specific services outlined above

This Agreement does not require a retainer. Invoices will be processed: Monthly Bi-Weekly At Completion, in accordance with completion levels of work.

If this offer is not executed and delivered to DMK Associates, Incorporated on or before March 29, 2013 this offer may be withdrawn.

I hereby authorize the firm of DMK Associates, Incorporated to perform the above services on the above described property. I have read and fully understand the "General Conditions" and "Hourly Fee Sheet" attached to this Agreement. I understand that the agreed upon fee will cover the cost of services provided within limitations stipulated in the "General Conditions" and "Hourly Fee Sheet." I hereby accept the terms and conditions of this Agreement.

Client: John R. Sawyer Title: V P Date: 1/29/14

As To DMK Associates, Incorporated: Jay S. Johansen Title: Project Mgr. Date: 2-19-2013

PLEASE SIGN AND RETURN ONE COPY TO OUR OFFICE

GENERAL CONDITIONS

1. **DEFINITIONS:**
 - CLIENT:** Owner of the project, responsible for obtaining and paying for all the services defined in this agreement, either directly or indirectly, through a consultant, contractor, subcontractor, or any other party.
 - OWNER:** The individual, firm, or entity, to whom title of the project and/or real estate is transferred upon completion of the Agreement for services, and who shall be the party with whom the Consultant shall contract for the Project's Services.
 - CONSULTANT:** The individual, firm, or entity, who operates under the Florida Corporation Act and is operating solely with their agents or representatives.
 - SCOPE OF SERVICES AND FEES:** Those services described within the attached Scope of Services and Fees of the Consultant.
 - ADDITIONAL SERVICES:** All services requested by the Client that are not included within the Scope of Services and Fees of the Agreement and requiring assistance beyond those set forth in the Scope of Services and Fees (Additional Fees) shall be an addendum with the Consultant/Client under other arrangements and made in writing.
 - AGREEMENT:** Shall include the legally binding written contract outlining the obligations, dates, and scope of the Client and Consultant. The Agreement shall govern the Scope of Services and Fees, the General Conditions, and the Hourly Fee Sheet.
 - HOURLY FEE SHEET:** Consultant's rates to be re-evaluated on a periodic basis and may include but not limited to the attached hereto, and that shall be made a part of every General Condition by reference.
2. **RESPONSIBILITY:** The Client and Consultant, and any third party, shall be responsible for obtaining all permits under the Agreement as well as all other permits, including delinquent fees due for Consultant, including professional attorney fees.
3. **PRIME SERVICES OF THE CONSULTANT:** Consultant agrees to provide basic services as defined within the attached "Scope of Services and Fees". The Scope of Services and Fees shall include as a minimum: A) date and term of the Agreement; B) basic fees for the Scope of Services defined; and C) means fees for any Additional Services. All other conditions of the Agreement shall be as presented within these General Conditions. In the event of a conflict between the Scope of Services and Fees and the General Conditions, the General Conditions shall prevail and all other specified services shall be deemed Additional Services. The following list of services shall be deemed as Additional Services unless specifically included by name: Archaeological/Historical Studies, Architecture, Landscape Architecture, Ingot or Design, Electrical/Mechanical Engineering, Environmental/Biological Services, Traffic Studies, TxDOT Permitting, Water Use Permitting, Construction Staking, Easement Preparation, or Special Purpose Surveys.
4. **CLIENT'S RESPONSIBILITY:** The Client shall be responsible for providing all necessary information required by the Consultant in conducting the work under this Agreement. The Client shall provide as a minimum: 1) right of entry to the project site; 2) ground surveys and study data on the project and site; 3) title work showing all encumbrances on the property; and 4) thorough and timely responses to all of the Consultant's requests for information.
5. **CONFIDENTIALITY AND OWNERSHIP OF DOCUMENTS:** All services provided by the Consultant are for the benefit of the parties specifically named. No other person or entity may use any information provided by Consultant under this Agreement without the Consultant's prior written consent. All original documents and copies thereof, produced as a direct or indirect result of this Agreement, shall be the property of the Consultant, and any reuse by the Client or Owner shall be prohibited. Consultant reserves the right to reuse all documents without consent of the Client or Owner.
6. **TERMS OF PAYMENT:** All fees for services rendered under this Agreement will be invoiced to the Client on a monthly basis. All invoices are due upon receipt and subject to a late fee and finance charge of 1.5% per month which is an annual rate of 18%, or the maximum allowable by law, on any balance past due more than thirty (30) days after the date of the invoice. In the event Client fails to pay Consultant within thirty (30) days of the invoice date, Client agrees that Consultant has the right to consider the Agreement breached and, upon five (5) days written notice, terminate all services and demand full payment for all services rendered. During the notice period, Client shall have the right to remedy all payment issues with no restart penalty. Client further agrees that if paid the termination period expires without resolution of payment issues, there will be a restart fee for re-commencing the project upon payment for all debts due. That fee shall be no less than 10% of the total value of the Agreement.
7. **CHANGED CONDITIONS AND ADDITIONAL SERVICES:** Any changes, modifications, additions, or substitutions made to this Agreement, either orally or written, will result in additional fees and charges. Additional fees will be based upon Consultant's hourly rates as detailed on the attached Hourly Fee Sheet. Changes in conditions shall include any modification directed or requested by the Client, any changes in laws, rules, regulations, policies, or ordinances of any regulatory agency having jurisdiction over the work, any changes to the Scope of Services and Fees of this Agreement beyond the Consultant's control, and any work which, at the Consultant's sole discretion, is outside of the scope of this Agreement and necessary for the proper sequencing and completion of the Agreement.
8. **OUTSIDE CHARGES, SUB CONSULTANT FEES AND REIMBURSABLES:** The services of the Consultant do not include fees for permits, permit inspections, application fees, consultants, attorney fees, title searches, abstracts, reproduction fees, travel, or any other "outsider" or "sub-consultant" charges or services not specifically detailed within the Scope of Services and Fees of the Agreement. All such costs are subject to a 10% surcharge if invoiced through the offices of the Consultant.
9. **TERMINATION:** All work under this Agreement may be terminated, with or without cause, by either party, upon five (5) days written notice. Upon termination, Consultant shall be entitled to payment for all services rendered up to the time of termination subject to all original Terms of Payment.
10. **ASSIGNMENT:** Client agrees that no portion of this Agreement may be assigned to any party other than the assigns or representatives of the Consultant.
11. **FEES SCHEDULE ADJUSTMENT:** Hourly fees will be charged at the rates in force during the time the services are rendered. Consultant reserves the right to adjust hourly rates annually and charge the most current fees for all services rendered.
12. **DIGITAL MEDIA:** Digital media and data are supplied at the Client's sole risk. Consultant assumes no responsibility for the existence of viruses or defects in the transmitted digital files or media. Client agrees to verify the data to assure its accuracy for the intended use. In the event of a conflict between digital information and certified records drawings, the drawings shall prevail. Consultant reserves the right to revise, update, and improve its electronic data without notice or liability.
13. **GOVERNMENTAL AND/OR REGULATORY AGENCY ACTIONS:** Consultant shall not be liable for damages resulting from delays, actions, inactions, or conflicts or pauses upon the Consultant's work by any Governmental or Regulatory Agency or their assigns. No guarantee, either written or implied, is made regarding the receipt, adequacy, or sufficiency of any Governmental or Regulatory Permit.
14. **ENFORCEMENT:** Should actions be necessary to enforce any provision of this Agreement, or to collect any portion of fees or debts payable, the Client shall pay for all costs of litigation, collection expenses, witness fees, court costs, and reasonable attorney fees to the Consultant should the Consultant prevail. In the event Client initiates a complaint or law suit against Consultant due to an alleged failure to perform, error, omission, or act of negligence and the suit is not successfully prosecuted, the Client agrees to pay all original and additional Consultant fees and any and all costs of defense, including reasonable attorney fees and associated court costs. All parties to this Agreement agree to waive all rights to a trial by jury in any and all disputes.
15. **LEGAL JURISDICTION AND SEVERABILITY:** Client and Consultant agree that any action brought to enforce any provision of this Agreement shall only be brought in a court of competent jurisdiction located in Sarasota County, Florida. Should any provision of this Agreement be unenforceable for any reason, all other provisions shall remain in force and enforceable to the maximum extent of the law.
16. **FIDUCIARY RESPONSIBILITY:** It is mutually agreed that neither the Consultant nor any of the Consultant's sub-consultants have a fiduciary responsibility to the Client or Owner.
17. **LIMITS OF LIABILITY:** To the fullest extent permitted by law, the execution of this Agreement limits Consultant's liability for damages to the sort of Consultant's professional fees charged and collected. This limitation shall apply regardless of the cause of action or legal theory pled or asserted.

18. **STANDARD OF CARE:** The obligation of the engineer is that of a professional. Any error or omission in the Agreement shall be deemed a "deficiency" standard of care. Total services rendered shall not be held liable for the deduction of a fee. The quality of services rendered is the responsibility of the engineer. The quantity of work is not a guarantee of quality. The engineer shall not be held liable for the same to the extent of the contract or otherwise.
19. **ENTIRE AGREEMENT:** This schedule along with the Scope of Services and Fee Schedule Sheet represent the entire Agreement between the parties. If the client or the Agreement is deleted or altered more than 30 days after the subject work date, then the terms may be subject to change.

DMK ASSOCIATES, INC.
STANDARD FEE SHEET
Effective March 1, 2009

<u>FEE SCHEDULE</u>	<u>Hourly Fee</u>
Principal	\$ 180.00
Sr. Project Manager	\$ 140.00
Project Manager	\$ 125.00
Project Engineer/Sr. Surveyor	\$ 115.00
Design Engineer/Surveyor	\$ 95.00
Engineer/Designer	\$ 90.00
Sr. CAD Technician IV	\$ 80.00
CAD Technician III	\$ 75.00
CAD Technician II	\$ 65.00
CAD Technician I	\$ 60.00
Sr. Inspector	\$ 65.00
Sr. Party Chief/ Inspector/Field Tech	\$ 70.00
Sr. Instrument Man/Inspector 3/Field Tech 3	\$ 65.00
Instrument Man/Inspector/Field Tech	\$ 45.00
Rodman	\$ 35.00
Administrative V	\$ 65.00
Administrative IV	\$ 60.00
Administrative III	\$ 50.00
Administrative II	\$ 45.00
Administrative I	\$ 40.00
 <u>FEE SCHEDULE</u>	 <u>Hourly Fee</u>
Delivery	\$ 40.00
Expenses other than field & office supplies	Cost + 10%
Barrier Island Surcharge	\$110.00 flat rate
Motor Boat (combined with Survey Crew)	\$ 20.00 / hour
GPS Equipment (combined with Survey Crew)	\$ 30.00 / hour
Concrete Monuments	\$ 30.00 / each
<u>Photo Copies:</u>	
"A" copies - 8 1/2" x 11"	\$.40 each
"B" copies - 11" x 17"	\$ 1.25 each
"C" copies - 18" x 24"	\$ 3.00 each
"D" copies - 24" x 36"	\$ 5.00 each
 Certification (sign/seal)	 \$ 10.00 each
Retrieval Fee (over 30 days)	\$ 25.00 each
Digital File (per disk)	\$ 50.00 each
Mileage	\$.50 per mile

#22

LITTLE GASPARILLA WTR UTIL INC.
P. O. BOX 5159
GROVE CITY, FL 34224

BB&T
BRANCH BANKING AND TRUST COMPANY
1-800-BANK BBT BBT.com

4138

PAY TO THE
ORDER OF

Dept. of Environmental Protection
six hundred & fifty & 00/100

4/8/14
\$ 650⁰⁰

DOLLARS

MEMO

Permit App.

AUTHORIZED SIGNATURE

⑈004138⑈



REDACTED

LITTLE GASPARILLA WTR UTIL INC.
P. O. BOX 5159
GROVE CITY, FL 34224

BB&T
BRANCH BANKING AND TRUST COMPANY
1-800-BANK BBT BBT.com

4173

PAY TO THE
ORDER OF

Dept of ENVIRONMENTAL Protection
five hundred & 00/100

5-11-14
\$ 500⁰⁰

DOLLARS

MEMO

AUTHORIZED SIGNATURE

⑈004173⑈



Details on Back
Security Features Included

Dec.
2014



421 Commercial Court, Suite C
 Venice, FL 34292
 Phone (941) 412-1293
 Fax (941) 412-1043
 admin@dmkassoc.com

22

Past

Little Gasparilla Water Utility, Inc
 PO Box 5145
 Grove City, FL 34224
 Jack Boyer

Invoice number 8826
 Date 01/31/2014
 Project 13-0209 Little Gasparilla Island Facilities Upgrade

Wood Frame Structural Design

Task 1: Design, drafting and permitting services for the demolition and reconstruction of a wood frame pump house at Little Gasparilla Island Utility (LGIU). Engineering design and permitting services for a 3,300 LF directional bore, 8 inch waterline connecting Charlotte County Utilities to LGIU. Engineering and design services for an 1,800 LF, 4 inch water line from King street to the north end of LGI.

Task 2: Permitting in accordance with FAC 62.555.330.

Task 3: Preparation of sovereign submerged land lease for approximately 3,000 LF of crossing between Cape Haze and LGI. Preparation of easements for WCIND and Cape Cave Corp. review.

Structural engineering, environmental and bathymetric survey and geotechnical work is specifically omitted from this scope of work per PSA dated February 19, 2014.

Invoice Summary

Inter connect

Description	Current Billed
TASK 1 BUILDING AND PIPELINE DESIGN	461.25
<i>Development of design criteria. Contract geotechnical firms for quote.</i>	
TASK 2 PERMITTING	2,670.00
<i>Site visit. Meeting with DEP regarding submittal.</i>	
TASK 3 LAND LEASE	0.00
<i>No work this period.</i>	
ADDITIONAL SERVICES	0.00
Total	3,131.25

Task 1 Building and Pipeline Design

Development of design criteria. Contract geotechnical firms for quote.

Professional Services

	Hours	Rate	Billed Amount
A2-Administration 2	0.25	45.00	11.25
PC6-Professional Consultant 6	2.50	180.00	450.00
Phase subtotal			461.25

Task 2 Permitting

Site visit. Meeting with DEP regarding submittal.

Professional Services

	Hours	Rate	Billed Amount
PC4-Professional Consultant 4	15.00	125.00	1,875.00
PC5-Professional Consultant 5	1.50	140.00	210.00
PC6-Professional Consultant 6	3.25	180.00	585.00

Task 2 Permitting

Miscellaneous meetings, establish design standards.

Professional Services

	Hours	Rate	Billed Amount
PC6-Professional Consultant 6	0.50	180.00	90.00
Reimbursables			3.30
Phase subtotal			713.30

Task 3 Land Lease

Field services, easement preparation, bathymetric work in progress.

Professional Services

	Hours	Rate	Billed Amount
CT4-CAD Tech 4	1.00	80.00	80.00
FT1-Field Tech 1	27.25	35.00	953.75
FT2-Field Tech 2	3.50	45.00	157.50
FT4-Field Tech 4	19.25	70.00	1,347.50
PC4-Professional Consultant 4	29.00	125.00	3,625.00
Phase subtotal			6,163.75
Invoice total			7,813.30

Aging Summary

Invoice Number	Invoice Date	Outstanding	Current	Over 30	Over 60	Over 90	Over 120
8826	01/31/2014	3,131.25		3,131.25			
8873	02/28/2014	7,813.30	7,813.30				
	Total	10,944.55	7,813.30	3,131.25	0.00	0.00	0.00

Approved by:

Karl W. Kokomoor
 President/CEO

Terms : Net Due Upon Receipt

TO RECEIVE INVOICES BY EMAIL, PLEASE EMAIL YOUR ADDRESS TO ap@dmkassoc.com



421 Commercial Court, Suite C

421 Commercial Court, Suite C
 Venice, FL 34292
 Phone (941) 412-1293
 Fax (941) 412-1043
 admin@dmkassoc.com

Little Gasparilla Water Utility, Inc
 PO Box 5145
 Grove City, FL 34224
 Jack Boyer

Invoice number 8873
 Date 02/28/2014

Project 13-0209 Little Gasparilla Island Facilities Upgrade

Facilities Upgrade, Design and Permitting

Task 1: Design, drafting and permitting services for the demolition and reconstruction of a wood frame pump house at Little Gasparilla Island Utility (LGIU). Engineering design and permitting services for a 3,300 LF directional bore, 8 inch waterline connecting Charlotte County Utilities to LGIU. Engineering and design services for an 1,800 LF, 4 inch water line from King street to the north end of LGI.

Task 2: Permitting in accordance with FAC 62.555.330.

Task 3: Preparation of sovereign submerged land lease for approximately 3,000 LF of crossing between Cape Haze and LGI. Preparation of easements for WCIND and Cape Cave Corp. review.

Structural engineering, environmental and bathymetric survey and geotechnical work is specifically omitted from this scope of work per PSA dated February 19, 2014.

Invoice Summary

Description	Current Billed
TASK 1 BUILDING AND PIPELINE DESIGN	936.25
<i>Authorization of survey work. Preliminary alignment, field coordination.</i>	
TASK 2 PERMITTING	713.30
<i>Miscellaneous meetings, establish design standards.</i>	
TASK 3 LAND LEASE	6,163.75
<i>Field services, easement preparation, bathymetric work in progress.</i>	
ADDITIONAL SERVICES	0.00
Total	7,813.30

Task 1 Building and Pipeline Design

Authorization of survey work. Preliminary alignment, field coordination.

Professional Services

	Hours	Rate	Billed Amount
A2-Administration 2	0.25	45.00	11.25
PC4-Professional Consultant 4	2.00	125.00	250.00
PC6-Professional Consultant 6	3.75	180.00	675.00
Phase subtotal			936.25

Task 2 Permitting

Miscellaneous meetings, establish design standards.

Professional Services

	Hours	Rate	Billed Amount
PC4-Professional Consultant 4	3.00	125.00	375.00
PC5-Professional Consultant 5	1.75	140.00	245.00

Task 3 Land Lease

1

Professional Services

	Hours	Rate	Billed Amount
CT4-CAD Tech 4	3.25	80.00	260.00
FT1-Field Tech 1	2.00	35.00	70.00
FT2-Field Tech 2	2.00	45.00	90.00
FT4-Field Tech 4	2.00	70.00	140.00
PC4-Professional Consultant 4	1.50	125.00	187.50
Phase subtotal			747.50

Invoice total **7,302.50**

Aging Summary

Invoice Number	Invoice Date	Outstanding	Current	Over 30	Over 60	Over 90	Over 120
8826	01/31/2014	3,131.25			3,131.25		
8873	02/28/2014	7,813.30		7,813.30			
8981	03/28/2014	7,302.50	7,302.50				
Total		18,247.05	7,302.50	7,813.30	3,131.25	0.00	0.00

Approved by:

Karl W. Kokomoor
 President/CEO

Terms : Net Due Upon Receipt

TO RECEIVE INVOICES BY EMAIL, PLEASE EMAIL YOUR ADDRESS TO ap@dmkassoc.com



421 Commercial Court, Suite C
 Venice, FL 34292
 Phone (941) 412-1293
 Fax (941) 412-1043
 admin@dmkassoc.com

Little Gasparilla Water Utility, Inc
 PO Box 5145
 Grove City, FL 34224
 Jack Boyer

Invoice number 8981
 Date 03/28/2014

Project **13-0209 Little Gasparilla Island Facilities Upgrade**

Facilities Upgrade, Design and Permitting

Task 1: Design, drafting and permitting services for the demolition and reconstruction of a wood frame pump house at Little Gasparilla Island Utility (LGIU). Engineering design and permitting services for a 3,300 LF directional bore, 8 inch waterline connecting Charlotte County Utilities to LGIU. Engineering and design services for an 1,800 LF, 4 inch water line from King street to the north end of LGI.

Task 2: Permitting in accordance with FAC 62.555.330.

Task 3: Preparation of sovereign submerged land lease for approximately 3,000 LF of crossing between Cape Haze and LGI. Preparation of easements for WCIND and Cape Cave Corp. review.

Structural engineering, environmental and bathymetric survey and geotechnical work is specifically omitted from this scope of work per PSA dated February 19, 2014.

Invoice Summary

Description	Current Billed
TASK 1 BUILDING AND PIPELINE DESIGN	6,532.50
1	
TASK 2 PERMITTING	22.50
1	
TASK 3 LAND LEASE	747.50
1	
ADDITIONAL SERVICES	0.00
Total	7,302.50

Task 1 Building and Pipeline Design

1

Professional Services

	Hours	Rate	Billed Amount
CT4-CAD Tech 4	33.00	80.00	2,640.00
PC4-Professional Consultant 4	22.50	125.00	2,812.50
PC6-Professional Consultant 6	6.00	180.00	1,080.00
Phase subtotal			6,532.50

Task 2 Permitting

1

Professional Services

	Hours	Rate	Billed Amount
A2-Administration 2	0.50	45.00	22.50



421 Commercial Court, Suite C
 Venice, FL 34292
 Phone (941) 412-1293
 Fax (941) 412-1043
 admin@dmkassoc.com

Little Gasparilla Water Utility, Inc
 PO Box 5145
 Grove City, FL 34224

Invoice number 8730
 Date 01/03/2014

Project 13-0209 Little Gasparilla Is. Utility
 Manager's Residence

Wood Frame Structural Design

For engineering services rendered through 12/20/13. Services include preparation of revised plans, review of design needs with drafting, preparation of letter to client outlining projected costs for PSC.

Invoice Summary

Description	Current Billed
STRUCTURAL	2,382.50
Total	2,382.50

Structural

Professional Services

Interconnect
Chen

	Hours	Rate	Billed Amount
A2-Administration 2	0.50	45.00	22.50
CT4-CAD Tech 4	13.75	80.00	1,100.00
PC6-Professional Consultant 6	7.00	180.00	1,260.00
Phase subtotal			2,382.50

Invoice total **2,382.50** ✓

Aging Summary

Invoice Number	Invoice Date	Outstanding	Current	Over 30	Over 60	Over 90	Over 120
8730	01/03/2014	2,382.50	2,382.50				
	Total	2,382.50	2,382.50	0.00	0.00	0.00	0.00

Approved by:

Karl W. Kokomoor
 President/CEO

Terms : Net Due Upon Receipt

TO RECEIVE INVOICES BY EMAIL. PLEASE EMAIL YOUR ADDRESS TO ad@dmkassoc.com

4:47 PM

05/08/14

Accrual Basis

Little Gasparilla Utilites
Account QuickReport
January through December 2013

Type	Date	Num	Name	Memo	Split	Amount
expansion/Bocilla Utilities						
Check	1/3/2013	3763	DMK Group		BB&T	2,000.00
Check	1/9/2013	3771	DMK Group		BB&T	1,747.50 ✓
Check	1/18/2013	3773	Knight Island Utilitie...		BB&T	1,123.50 ✓
Check	4/11/2013	3838	Knight Island Utilitie...		BB&T	1,176.00
Check	6/20/2013	3890	Knight Island Utilitie...		BB&T	451.50
Total expansion/Bocilla Utilities						6,498.50
TOTAL						6,498.50

Statement

Venice Office
 435 Commercial Court, Suite 200
 Venice, FL 34292
 Phone (941) 412-1293
 Fax (941) 412-1043



Englewood Office
 4315 South Access Road
 Englewood, FL 34224
 Phone (941) 475-6596
 Fax (941) 474-5060

Little Gasparilla Water Utility, Inc
 PO Box 5159
 Grove City, FL 34224

Statement date: 9/4/2012

	Invoice Number	Invoice Date	Amount
--	----------------	--------------	--------

Little Gasparilla Water Utility, Inc
 09-0164 Little Gasparilla Water Utility - Bulk Water from
 CCU

7503	4/13/2012	<i>Pd</i>	2,797.50
7678	6/30/2012		5,345.00
Client Outstanding			8,142.50
			3147.50

Little Gasparilla Water Utility, Inc						Prepayment
Outstanding	Current	31-60 Days	61-90 Days	91-120 Days	121+ Days	
8,142.50	0.00	0.00	5,345.00	0.00	2,797.50	0.00

PAST DUE!
 WE WOULD APPRECIATE YOUR
 PAYMENT TODAY!

Pd 2000.00 1/4
 1747.50

LITTLE GASPARILLA WTR UTIL INC.

DMK Group

1/9/2013

3771

1,747.50

BB&T

1,747.50

LITTLE GASPARILLA WTR UTIL INC.

DMK Group

1/9/2013

3771

1,747.50

BB&T

1,747.50

LMP12 M/P CHECK

51N311/39287



435 Commercial Court, Suite 200
 Venice, FL 34292
 Phone (941) 412-1293
 Fax (941) 412-1043

Little Gasparilla Water Utility, Inc
 PO Box 5159
 Grove City, FL 34224
 Jack Boyer

Invoice number 8163
 Date 04/01/2013

Project **09-0164 Little Gasparilla Water Utility - Bulk Water from CCU**

Design & FDEP Permit 8-inch Potable Water Line Interconnect with CCU

For services rendered through 3/22/13 to prepare a letter with photographs describing the extent and probable causes of the deterioration of the R/O plant pump station. Prepare an aerial photograph with overlay of the proposed directional bore under the ICW and identified two parcels owned by WCIND and the Cape Cave Corp. the directional bore might need permission to go under. Emailed aerial plan to WCIND and Cape Cave.

Little Gasparilla Island

Invoice Summary

Description	Contract Amount	Percent Complete	Total Billed	Prior Billed	Remaining	Current Billed
HDD ROUTE AERIAL & P/H LETTER	1,000.00	60.75	607.50	0.00	392.50	607.50
Total	1,000.00	60.75	607.50	0.00	392.50	607.50

HDD Route Aerial & P/H Letter

Professional Services

	Hours	Rate	Billed Amount
A2-Administration 2	4.00	45.00	180.00
PC2-Professional Consultant 2	4.50	95.00	427.50
Phase subtotal			607.50
Invoice total			607.50

Aging Summary

Invoice Number	Invoice Date	Outstanding	Current	Over 30	Over 60	Over 90	Over 120
8163	04/01/2013	607.50	607.50				
	Total	607.50	607.50	0.00	0.00	0.00	0.00

Approved by:

OK per J.B.

Jay S. Johansen
 Project Manager

Phase subtotal 2,670.00

Invoice total 3,131.25

Aging Summary

Invoice Number	Invoice Date	Outstanding	Current	Over 30	Over 60	Over 90	Over 120
8826	01/31/2014	3,131.25	3,131.25				
	Total	3,131.25	3,131.25	0.00	0.00	0.00	0.00

Approved by:

Karl W. Kokomoor
President/CEO

Terms : Net Due Upon Receipt

TO RECEIVE INVOICES BY EMAIL, PLEASE EMAIL YOUR ADDRESS TO ap@dmkassoc.com



435 Commercial Court, Suite 200
 Venice, FL 34292
 Phone (941) 412-1293
 Fax (941) 412-1043

Little Gasparilla Water Utility, Inc
 PO Box 5159
 Grove City, FL 34224
 Jack Boyer

Invoice number 8240
 Date 05/06/2013

Project **09-0164 Little Gasparilla Water Utility - Bulk Water from CCU**

Design & FDEP Permit 8-inch Potable Water Line Interconnect with CCU

For services rendered through 4/26/13 to research history and files for Little Gasparilla Island water storage tank construction plans. Found some structural plans in Alchemy and other plans on P-drive under number 91-1022. Made copies and delivered to client.

Little Gasparilla Island

Invoice Summary

Description	Contract Amount	Percent Complete	Total Billed	Prior Billed	Remaining	Current Billed
HDD ROUTE AERIAL & P/H LETTER	1,000.00	84.50	845.00	607.50	155.00	237.50
Total	1,000.00	84.50	845.00	607.50	155.00	237.50

HDD Route Aerial & P/H Letter

Professional Services

	Hours	Rate	Billed Amount
PC2-Professional Consultant 2	2.50	95.00	237.50

Invoice total **237.50**

Aging Summary

Invoice Number	Invoice Date	Outstanding	Current	Over 30	Over 60	Over 90	Over 120
8240	05/06/2013	237.50	237.50				
	Total	237.50	237.50	0.00	0.00	0.00	0.00

Approved by:

Jay S. Johansen
 Project Manager

Terms : Net Due Upon Receipt

TO RECEIVE INVOICES BY EMAIL, PLEASE EMAIL YOUR ADDRESS TO ap@dmkassoc.com

LITTLE GASPARILLA WTR UTIL INC.

Knight Island Utilities, Inc.

1/18/2013

3773

1,123.50

BB&T

1,123.50

LITTLE GASPARILLA WTR UTIL INC.

Knight Island Utilities, Inc.

1/18/2013

3773

1,123.50

BB&T

1,123.50

LMP12 M/P CHECK

51N311/39287

Little Gasparilla Utilites
Account QuickReport
 January through December 2012

Type	Date	Num	Name	Memo	Split	Amount
expansion/Bocilla Utilites						
Check	1/5/2012	3479	DMK Group		BB&T	1,221.25
Check	1/26/2012	3492	Knight Island Utilitie...		BB&T	283.50
Check	3/21/2012	3533	DMK Group		BB&T	1,632.50
Check	4/11/2012	3555	Knight Island Utilitie...		BB&T	2,776.30
Check	5/22/2012	3588	DMK Group	permitting	BB&T	1,135.00
Check	8/10/2012	3657	Knight Island Utilitie...		BB&T	551.25
Check	8/23/2012	3666	Knight Island Utilitie...		BB&T	777.00
Check	9/20/2012	3682	DMK Group	#7503	BB&T	2,797.50
Check	9/20/2012	3683	Knight Island Utilitie...		BB&T	588.00
Check	11/8/2012	3722	Knight Island Utilitie...		BB&T	451.50
Check	12/19/2012	3745	Knight Island Utilitie...		BB&T	63.00
General Journal	12/31/2012	AJE 7		To reclass ex...	Expansion/Bo...	-12,276.80
Total expansion/Bocilla Utilites						0.00
TOTAL						0.00

5/22/12

Knight Isl.

462.00 ✓

~~12,276.80~~

\$ 12,738.96 ✓

7/18/12 Knight.

126.00

11/20/12 Knight.

262.50

12/19/12 Knight

861.00

13,988.30

Venice Office
 435 Commercial Court, Suite 200
 Venice, FL 34292
 Phone (941) 412-1293
 Fax (941) 412-1043



Englewood Office
 4315 South Access Road
 Englewood, FL 34224
 Phone (941) 475-6596
 Fax (941) 474-5060

435 Commercial Court
 Suite 200
 Venice, FL 34292

Little Gasparilla Water Utility, Inc
 PO Box 5159
 Grove City, FL 34224
 Jack Boyer

Invoice number 7503
 Date 04/13/2012

Project **09-0164 Little Gasparilla Water Utility - Interconnect with CCU**

Design & FDEP Permit 8-inch Potable Water Line Interconnect with CCU

For services rendered through 3/30/12 to review Jon Iglehart's letter claiming FDEP's South District's ownership of the LGWU project. Met with Jack Boyer at DMK to plan strategy for the upcoming meeting at FDEP, met with James Oni, Jon Iglehart, Mr. Ahmari, and Jack Boyer.

Although the results of the meeting seemed encouraging, Mr. Iglehart's backtracking on his FPL easement assertions brought the project back to square one. DMK attended a site meeting with FDEP's Recreation & Park and ERP personnel at Don Pedro Island State Park on 3/29/12 to agree on the water main route from the ICW to the wetland crossing south of Don Pedro Island State Park.

Little Gasparilla Island

Invoice Summary

Description	Contract Amount	Total Billed	Prior Billed	Remaining	Current Billed
BULK WATER PERMITTING	3,000.00	577.50	577.50	2,422.50	0.00
STATE PARK EASEMENT	3,800.00	6,573.75	3,776.25	-2,773.75	2,797.50
DESIGN AND FDEP PERMIT	12,556.70	14,544.86	14,544.86	-1,988.16	0.00
Total	19,356.70	21,696.11	18,898.61	-2,339.41	2,797.50

State Park Easement

Professional Services

	Hours	Rate	Billed Amount
PC2-Professional Consultant 2	16.50	95.00	1,567.50
PC5-Professional Consultant 5	7.50	140.00	1,050.00
PC6-Professional Consultant 6	1.00	180.00	180.00
Phase subtotal			2,797.50
Invoice total			2,797.50

Aging Summary

Invoice Number	Invoice Date	Outstanding	Current	Over 30	Over 60	Over 90	Over 120
7409	02/29/2012	1,135.00		1,135.00			
7503	04/13/2012	2,797.50	2,797.50				
Total		3,932.50	2,797.50	1,135.00	0.00	0.00	0.00

Venice Office
 Commercial Court, Suite 200
 Venice, FL 34292
 Phone (941) 412-1293
 Fax (941) 412-1043



Englewood Office
 4315 South Access Road
 Englewood, FL 34224
 Phone (941) 475-6596
 Fax (941) 474-5060

435 Commercial Court
 Suite 200
 Venice, FL 34292

Little Gasparilla Water Utility, Inc
 PO Box 5159
 Grove City, FL 34224
 Jack Boyer

Invoice number 7327
 Date 01/31/2012

Project **09-0164 Little Gasparilla Water Utility - Interconnect with CCU**

Design & FDEP Permit 8-inch Potable Water Line Interconnect with CCU

For services rendered through 1/27/12 to complete DMK's aerial map showing proposed water main routes for the LGWU Upland Easement Application, made adjustments per Jack Boyer's (JB) comments. Utilized the Upland Easement Application to identify necessary contributors of documents required as attachments to the application and emailed to Charlotte County Zoning, FDEP's Recreation & Parks, and JB. Received and responded to numerous emails and telecons from Charlotte County, FDEP, and JB. DMK clarified several issues raised by Charlotte County and received their "Letter of Consistency".

Little Gasparilla Island

Invoice Summary

Description	Contract Amount	Total Billed	Prior Billed	Remaining	Current Billed
BULK WATER PERMITTING	3,000.00	577.50	577.50	2,422.50	0.00
STATE PARK EASEMENT	3,800.00	2,641.25	1,008.75	1,158.75	1,632.50
DESIGN AND FDEP PERMIT	12,556.70	14,544.86	14,544.86	-1,988.16	0.00
Total	19,356.70	17,763.61	16,131.11	1,593.09	1,632.50

State Park Easement

Professional Services

	Hours	Rate	Billed Amount
A2-Administration 2	1.50	45.00	67.50
PC2-Professional Consultant 2	15.00	95.00	1,425.00
PC5-Professional Consultant 5	1.00	140.00	140.00
Phase subtotal			1,632.50

Invoice total 1,632.50

Aging Summary

Invoice Number	Invoice Date	Outstanding	Current	Over 30	Over 60	Over 90	Over 120
7327	01/31/2012	1,632.50	1,632.50				
Total		1,632.50	1,632.50	0.00	0.00	0.00	0.00

Venice Office
 435 Commercial Court, Suite 200
 Venice, FL 34292
 Phone (941) 412-1293
 Fax (941) 412-1043



Englewood Office
 4315 South Access Road
 Englewood, FL 34224
 Phone (941) 475-6596
 Fax (941) 474-5060

435 Commercial Court
 Suite 200
 Venice, FL 34292

Little Gasparilla Water Utility, Inc
 PO Box 5159
 Grove City, FL 34224
 Jack Boyer

Invoice number 7409
 Date 02/29/2012

Project 09-0164 Little Gasparilla Water Utility -
 Interconnect with CCU

Design & FDEP Permit 8-inch Potable Water Line Interconnect with CCU

For engineering services rendered through 2/24/12. Services rendered include continued work with Jack Boyer on the Upland Easement Application and all required supporting documents from Charlotte County, FDEP, and Little Gasparilla Water Utility. Created a LGWU logo and combined all required easement application documents into a several page response with referenced documents.

Received a letter from the Director of FDEP's South District Office, Jon Iglehart, and attended a meeting with Mr. Iglehart, James Oni, and Dr. Ahmadi on 2/21/12, in which very encouraging progress was made.

Little Gasparilla Island

Invoice Summary

Description	Contract Amount	Total Billed	Prior Billed	Remaining	Current Billed
BULK WATER PERMITTING	3,000.00	577.50	577.50	2,422.50	0.00
STATE PARK EASEMENT	3,800.00	3,776.25	2,641.25	23.75	1,135.00
DESIGN AND FDEP PERMIT	12,556.70	14,544.86	14,544.86	-1,988.16	0.00
Total	19,356.70	18,898.61	17,763.61	458.09	1,135.00

State Park Easement

Professional Services

	Hours	Rate	Billed Amount
A2-Administration 2	2.00	45.00	90.00
PC2-Professional Consultant 2	11.00	95.00	1,045.00
Phase subtotal			1,135.00
Invoice total			1,135.00

Aging Summary

Invoice Number	Invoice Date	Outstanding	Current	Over 30	Over 60	Over 90	Over 120
7327	01/31/2012	1,632.50		1,632.50			
7409	02/29/2012	1,135.00	1,135.00				
Total		2,767.50	1,135.00	1,632.50	0.00	0.00	0.00

Knight Island Utilities, Inc.

Attn: Flip

7092 Placida Road

Cape Haze, FL 33946

Invoice

Date	Invoice #
4/18/2012	21

Bill To
LITTLE GASPARILLA UTILITIES ATTN: JACK BOYER PO BOX 5159 GROVE CITY, FL 34224

Memo	Item	Class	Account #	Amount
SEE ATTACHED INVOICE FROM WOTITZKY INV 12	MISCELLANEOUS EXPENSES			777.00
			Total	
			Payments/Credits	
			Balance Due	\$777.00

Sanight Island Utilities, Inc.

Attn: Flip
7092 Placida Road
Cape Haze, FL 33946

Invoice

Date	Invoice #
3/19/2012	17

Bill To
LITTLE GASPARILLA UTILITIES ATTN: JACK BOYER PO BOX 5159 GROVE CITY, FL 34224

			Account #
Memo	Item	Class	Amount
SEE ATTACHED INVOICE FROM WOTITZKY INV 11	MISCELLANEOUS EXPENSES		551.25

Light Island Utilities, Inc.

Attn: Flip
7092 Placida Road
Cape Haze, FL 33946

Invoice

Date	Invoice #
1/9/2012	11

Bill To
LITTLE GASPARILLA UTILITIES ATTN: JACK BOYER PO BOX 5159 GROVE CITY, FL 34224

			Account #
Memo	Item	Class	Amount
SEE ATTACHED INVOICE FROM WOTITZKY INV 9	MISCELLANEOUS EXPENSES		283.50
		Total	
		Payments/Credits	
		Balance Due	\$283.50

Island Utilities, Inc.

Attn: Flip
 7092 Placida Road
 Cape Haze, FL 33946

Invoice

Date	Invoice #
5/22/2012	24

Bill To
LITTLE GASPARILLA UTILITIES ATTN: JACK BOYER PO BOX 5159 GROVE CITY, FL 34224

Memo	Item	Class	Account #	Amount
SEE ATTACHED INVOICE FROM WOTITZKY INV 13	MISCELLANEOUS EXPENSES			462.00
			Total	
			Payments/Credits	
			Balance Due	\$462.00

4:59 PM

05/08/14

Accrual Basis

Little Gasparilla Utilites

Account QuickReport

January through December 2011

Type	Date	Num	Name	Memo	Split	Amount
Professional Fees						
consultation fee water line ext		(SARC)	Rate Case	Application Fee		1,000.00
Check	12/5/2011	3450	Charlotte County B...		BB&T	1,221.25 ✓
General Journal	12/31/2011	AJE 1...		AJE 4; To ac...	A/P	1,221.25
Total <u>consultation fee water line ext</u>						2,221.25
Total Professional Fees						2,221.25
TOTAL						2,221.25
						<u>1221</u> 25

Venice Office
 435 Commercial Court, Suite 200
 Venice, FL 34292
 Phone (941) 412-1293
 Fax (941) 412-1043



Englewood Office
 4315 South Access Road
 Englewood, FL 34224
 Phone (941) 475-6596
 Fax (941) 474-5060

435 Commercial Court
 Suite 200
 Venice, FL 34292

Little Gasparilla Water Utility, Inc
 PO Box 5159
 Grove City, FL 34224
 Jack Boyer

Invoice number 7244
 Date 12/14/2011

Project 09-0164 Little Gasparilla Water Utility -
 Interconnect with CCU

Design & FDEP Permit 8-inch Potable Water Line Interconnect with CCU

For services rendered through 12/9/11 to participate in two conference calls with FDEP's State Lands, Recreation and Parks and Environmental Resource Permitting to discuss strategy for obtaining an easement across Don Pedro Island State Park and FDEP permitting of a bulk water line. Received and analyzed existing State Lands Easement Information from FDEP. Delineated responsible parties for easement request and discussed with several Charlotte County personnel. Preparing easement request map of the 8-inch water main to the Englewood Water District and Charlotte County Utilities.

Little Gasparilla Island

Invoice Summary

Description	Contract Amount	Total Billed	Prior Billed	Remaining	Current Billed
BULK WATER PERMITTING	3,000.00	577.50	365.00	2,422.50	212.50
STATE PARK EASEMENT	3,800.00	1,008.75	0.00	2,791.25	1,008.75
DESIGN AND FDEP PERMIT	12,556.70	14,544.86	14,544.86	-1,988.16	0.00
Total	19,356.70	16,131.11	14,909.86	3,225.59	1,221.25

Bulk Water Permitting

Professional Services

	Hours	Rate	Billed Amount
PC2-Professional Consultant 2	1.50	95.00	142.50
PC5-Professional Consultant 5	0.50	140.00	70.00
Phase subtotal			212.50

State Park Easement

Professional Services

	Hours	Rate	Billed Amount
A2-Administration 2	0.25	45.00	11.25
PC2-Professional Consultant 2	10.50	95.00	997.50
Phase subtotal			1,008.75

Invoice total **1,221.25**

Venice Office
 455 Commercial Court, Suite 200
 Venice, FL 34292
 Phone (941) 412-1293
 Fax (941) 412-1043



Englewood Office
 4315 South Access Road
 Englewood, FL 34224
 Phone (941) 475-6596
 Fax (941) 474-5060

435 Commercial Court
 Suite 200
 Venice, FL 34292

Little Gasparilla Water Utility, Inc
 PO Box 5159
 Grove City, FL 34224
 Jack Boyer

Invoice number 7678
 Date 10/09/2012

Project **09-0164 Little Gasparilla Water Utility - Bulk Water from CCU**

Design & FDEP Permit 8-inch Potable Water Line Interconnect with CCU

Revised Invoice

For services rendered through 6/29/12 for continuing email and phone exchanges with FDEP on the upland and SSL easements, and ERP requirements. DMK met with client to discuss new proposal requirements that included the 8-inch bulk water main, booster-pump station, pole barn, and an operator's office over the water storage tank. Revised upland easement application to reflect new pipeline route along the existing path in Don Pedro Island State Park and UPS'ed to James Oni, PE.

Met with Jack Boyer to review new DMK proposal and directional boring options from Cape Haze Drive to the north end of Little Gasparilla Island, prepare a map showing four potential direction drill set-up locations with estimated distances and emailed the map to seven directional bore contractors for comment.

Attended meeting at CCU with Jack Boyer and discovered the bulk water rate was over 50% greater than originally indicated by attorney.

Little Gasparilla Island

Invoice Summary

Description	Contract Amount	Total Billed	Prior Billed	Remaining	Current Billed
TASK 1-ENGINEERING DESIGN	22,500.00	3,092.50	0.00	19,407.50	3,092.50
TASK 2-ENVIRONMENTAL	6,200.00	0.00	0.00	6,200.00	0.00
TASK 3-SURVEY	8,500.00	375.00	0.00	8,125.00	375.00
TASK 4-PERMITTING	24,800.00	280.00	0.00	24,520.00	280.00
Total	62,000.00	3,747.50	0.00	58,252.50	3,747.50

Task 1-Engineering Design

Professional Services

	Hours	Rate	Billed Amount
PC2-Professional Consultant 2	21.50	95.00	2,042.50
PC5-Professional Consultant 5	7.50	140.00	1,050.00
Phase subtotal			3,092.50

Task 3-Survey

Professional Services

	Hours	Rate	Billed Amount
PC4-Professional Consultant 4	3.00	125.00	375.00

Task 4-Permitting

Professional Services

	Hours	Rate	Billed Amount
PC5-Professional Consultant 5	2.00	140.00	280.00

Invoice total **3,747.50**

Aging Summary

Invoice Number	Invoice Date	Outstanding	Current	Over 30	Over 60	Over 90	Over 120
7678	10/09/2012	3,747.50	3,747.50				
	Total	3,747.50	3,747.50	0.00	0.00	0.00	0.00

Approved by:

Jay S. Johansen
 Project Manager

Terms : Net Due Upon Receipt

Pre-Billing Worksheet

09-0164 Little Gasparilla Water Utility - Bulk Water from CCU

Task 1-Engineering Design

Phase Status: Active

WIP - Bill As Time & Expense

Billing Cutoff: 06/29/2012

Billing Type: Time & Expense

Date	Units	Rate	Amount
------	-------	------	--------

To Bill	
Units	Amount

Labor WIP Status: Billable

A2-Administration 2

Stella Starns-Derflinger

Billable Time	04/24/2012	0.50	45.00	22.50	0.50	22.50
<i>typed proposal for LGIWU/Jack Boyer re: Bulk Water with CCU per Jay's notes.</i>						
Billable Time	06/01/2012	0.50	45.00	22.50	0.50	22.50
<i>researched & printed Southwest Florida Bore Contractors for bidding purposes per Jay's request.</i>						
Subtotal		1.00		45.00	1.00	45.00

PC2-Professional Consultant 2

Jay S. Johansen

Billable Time	04/04/2012	1.00	95.00	95.00	1.00	95.00
<i>email exchanges w/ James Oni re pursuing SSL easement sharing under the ICW and wetlands south of DPISP, same BS</i>						
Billable Time	04/12/2012	3.00	95.00	285.00	3.00	285.00
<i>met w/ Jack Boyer and KEM for two hours on new project 8-inch wm, pole barn and manager apt on R/O WTP storage tank, meeting transferred to KWK office to talk finances, reviewed Anger Fishing Pier proposal w/ KEM</i>						
Billable Time	04/13/2012	1.00	95.00	95.00	1.00	95.00
<i>discussed LGW proposal issues w/ KEM, sent C3 to Jim Elder as requested by CCU</i>						
Billable Time	04/24/2012	1.50	95.00	142.50	1.50	142.50
<i>wrote LGIWU Bulk Water From CCU proposal for KEM's review.... \$62,000</i>						
Billable Time	04/25/2012	2.00	95.00	190.00	2.00	190.00
<i>working on ADA proposal w/ Stacey M and LGIWU proposal w/ KEM</i>						
Billable Time	05/08/2012	2.50	95.00	237.50	2.50	237.50
<i>09-0164, revised response letter, completed FDEP Upland Easement Application and UPSed package to James Oni</i>						
Billable Time	05/30/2012	0.50	95.00	47.50	0.50	47.50
<i>discussed project w/ Jack Boyer, set up meeting</i>						
Billable Time	05/31/2012	1.00	95.00	95.00	1.00	95.00
<i>met w/ Jack Boyer to review contract and directional boring from Cape Haze to north side of LGI</i>						
Billable Time	06/01/2012	3.50	95.00	332.50	3.50	332.50
<i>prepared GIS map of the four possible directionally bored sections, researched Florida DB contractors, prepared email and sent to seven contractors</i>						
Billable Time	06/04/2012	1.50	95.00	142.50	1.50	142.50
<i>contacting HDD firms to get costs and constraints</i>						
Billable Time	06/05/2012	1.00	95.00	95.00	1.00	95.00
<i>discussions w/ Jeff Black from Arrow DB and Lisa email exchanges fom Gator DB</i>						
Billable Time	06/07/2012	3.50	95.00	332.50	3.50	332.50
<i>working on HDD questions w/ several companys, survey issues w/ Barry, met w/ KEM and Barry for conference call w/ James Oni</i>						
Billable Time	06/11/2012	1.50	95.00	142.50	1.50	142.50
Billable Time	06/14/2012	1.00	95.00	95.00	1.00	95.00
<i>discussed new LGWU proposal for HDD w/ KEM and Jack Boyer</i>						
Billable Time	06/14/2012	1.00	95.00	95.00	1.00	95.00
<i>discussed HDD with Jack B, spoil island construction constraints, new HDD location on south side to CCU, reviewed options w/ DLF, CCU meeting adgenda w/ JB</i>						

Pre-Billing Worksheet

09-0164 Little Gasparilla Water Utility - Bulk Water from CCU

Task 1-Engineering Design

Phase Status: Active

WIP - Bill As Time & Expense

Billing Cutoff: 06/29/2012

To Bill

Billing Type: Time & Expense

Date	Units	Rate	Amount
------	-------	------	--------

Units	Amount
-------	--------

Labor

WIP Status: Billable

PC2-Professional Consultant 2

Jay S. Johansen

Billable Time	06/18/2012	1.50	95.00	142.50	1.50	142.50
---------------	------------	------	-------	--------	------	--------

discuss options w/ KEM, made aeriels for mtg w/ JB and CCU on 6/19

Billable Time	06/19/2012	2.00	95.00	190.00	2.00	190.00
---------------	------------	------	-------	--------	------	--------

Subtotal		29.00		2,755.00	29.00	2,755.00
----------	--	-------	--	----------	-------	----------

PC5-Professional Consultant 5

Kreg E. Maheu

Billable Time	04/04/2012	1.00	140.00	140.00	1.00	140.00
---------------	------------	------	--------	--------	------	--------

Correspondence with FDEP and staff on permitting and route thru park; James Oni e-mail

Billable Time	04/12/2012	2.50	140.00	350.00	2.50	350.00
---------------	------------	------	--------	--------	------	--------

Meeting with Jack Boyer to reveiw engineering and permitting requirements for 8" WM extension

Billable Time	04/16/2012	1.00	140.00	140.00	1.00	140.00
---------------	------------	------	--------	--------	------	--------

LGWA - corresp w/ FDEP andscope of services with Jack Boyer and JSJ

Billable Time	04/25/2012	1.00	140.00	140.00	1.00	140.00
---------------	------------	------	--------	--------	------	--------

LGWA proposal w/ JSJ and review

Billable Time	04/27/2012	1.00	140.00	140.00	1.00	140.00
---------------	------------	------	--------	--------	------	--------

LGWA - proposal for env. services with Mike Conn and send info via e-mail

Billable Time	05/01/2012	1.50	140.00	210.00	1.50	210.00
---------------	------------	------	--------	--------	------	--------

LGWU proposal to Jack Boyer

Billable Time	05/24/2012	0.50	140.00	70.00	0.50	70.00
---------------	------------	------	--------	-------	------	-------

LGWA Contract status and State Park Easement w/ Client and JSJ

Billable Time	06/04/2012	1.00	140.00	140.00	1.00	140.00
---------------	------------	------	--------	--------	------	--------

Reveiw alternate HDD route with Jay

Billable Time	06/06/2012	0.50	140.00	70.00	0.50	70.00
---------------	------------	------	--------	-------	------	-------

PM w/ JSJ

Billable Time	06/07/2012	2.00	140.00	280.00	2.00	280.00
---------------	------------	------	--------	--------	------	--------

Meeting with JSJ and Barry McLeod on scope of work for survey; Correspondence with James Oni from FDEP

Billable Time	06/08/2012	1.50	140.00	210.00	1.50	210.00
---------------	------------	------	--------	--------	------	--------

Review status with JSJ; e-mail from JAMES Oni and discuss status with Client and JSJ/WAM

Subtotal		13.50		1,890.00	13.50	1,890.00
----------	--	-------	--	----------	-------	----------

Labor total		43.50		4,690.00	43.50	4,690.00
-------------	--	-------	--	----------	-------	----------

Phase Summary

Reported % Complete

Date Entered:

	Contract	Spent	%	Billed	%	Remaining	%	WIP	To Bill
Labor	22,500.00	4,690.00	21			22,500.00	100	4,690.00	21 4,690.00
Total	22,500.00	4,690.00	21			22,500.00	100	4,690.00	21 4,690.00

Pre-Billing Worksheet

09-0164 Little Gasparilla Water Utility - Bulk Water from CCU

Task 2-Environmental

Phase Status: Active

Phase Summary	Reported % Complete			Date Entered:				WIP	To Bill
	Contract	Spent	%	Billed	%	Remaining	%		
Labor	6,200.00					6,200.00	100		
Total	6,200.00					6,200.00	100		

3 Task 3-Survey

Phase Status: Active

WIP - Bill As Time & Expense

Billing Cutoff: 06/29/2012

To Bill

Billing Type: Time & Expense

Date	Units	Rate	Amount
------	-------	------	--------

Units	Amount
-------	--------

Labor

WIP Status: Billable

PC4-Professional Consultant 4

Warren A. McLeod

Billable Time	06/08/2012	2.00	125.00	250.00	2.00	250.00
<i>reseach project and old files</i>						
Billable Time	06/11/2012	1.00	125.00	125.00	1.00	125.00
<i>field recon for survey</i>						
	Subtotal	3.00		375.00	3.00	375.00
	Labor total	3.00		375.00	3.00	375.00

Phase Summary	Reported % Complete			Date Entered:				WIP	To Bill
	Contract	Spent	%	Billed	%	Remaining	%		
Labor	8,500.00	375.00	4			8,500.00	100	375.00	4 375.00
Total	8,500.00	375.00	4			8,500.00	100	375.00	4 375.00

Task 4-Permitting

Phase Status: Active

WIP - Bill As Time & Expense

Billing Cutoff: 06/29/2012

To Bill

Billing Type: Time & Expense

Date	Units	Rate	Amount
------	-------	------	--------

Units	Amount
-------	--------

Labor

WIP Status: Billable

PC5-Professional Consultant 5

Kreg E. Maheu

Billable Time	06/18/2012	0.50	140.00	70.00	0.50	70.00
<i>update with JSJ</i>						
Billable Time	06/20/2012	0.50	140.00	70.00	0.50	70.00
<i>Update of meeting with CCU</i>						
Billable Time	06/25/2012	1.00	140.00	140.00	1.00	140.00
<i>PM w/ client and FDEP for permit withdrawal</i>						
	Subtotal	2.00		280.00	2.00	280.00
	Labor total	2.00		280.00	2.00	280.00

Pre-Billing Worksheet

09-0164 Little Gasparilla Water Utility - Bulk Water from CCU

Phase Summary	Reported % Complete			Date Entered:					
	Contract	Spent	%	Billed	%	Remaining	%	WIP	To Bill
Labor	24,800.00	280.00	1			24,800.00	100	280.00	1 280.00
Total	24,800.00	280.00	1			24,800.00	100	280.00	1 280.00

Invoice Summary	Reported % Complete			Date Entered:					
	Contract	Spent	%	Billed	%	Remaining	%	WIP	To Bill
Labor	62,000.00	5,345.00	9			62,000.00	100	5,345.00	5,345.00
Expense									
Consultant									
Total	62,000.00	5,345.00	9			62,000.00	100	5,345.00	5,345.00

Venice Office
 435 Commercial Court, Suite 200
 Venice, FL 34292
 Phone (941) 412-1293
 Fax (941) 412-1043



Englewood Office
 4315 South Access Road
 Englewood, FL 34224
 Phone (941) 475-6596
 Fax (941) 474-5060

435 Commercial Court
 Suite 200
 Venice, FL 34292

Little Gasparilla Water Utility, Inc
 PO Box 5159
 Grove City, FL 34224
 Jack Boyer

Invoice number 7678
 Date 06/30/2012

Project **09-0164 Little Gasparilla Water Utility - Bulk Water from CCU**

Design & FDEP Permit 8-inch Potable Water Line Interconnect with CCU

For services rendered through 6/29/12 for continuing email and phone exchanges with FDEP on the upland and SSL easements, and ERP requirements. DMK met with client to discuss new proposal requirements that included the 8-inch bulk water main, booster-pump station, pole barn, and an operator's office over the water storage tank. Revised upland easement application to reflect new pipeline route along the existing path in Don Pedro Island State Park and UPS'ed to James Oni, PE.

Met with Jack Boyer to review new DMK proposal and directional boring options from Cape Haze Drive to the north end of Little Gasparilla Island, prepare a map showing four potential direction drill set-up locations with estimated distances and emailed the map to seven directional bore contractors for comment.

Jays Est #200

Attended meeting at CCU with Jack Boyer and discovered the bulk water rate was over 50% greater than originally indicated by attorney.

Little Gasparilla Island

Invoice Summary

Description	Contract Amount	Total Billed	Prior Billed	Remaining	Current Billed
TASK 1-ENGINEERING DESIGN	22,500.00	4,690.00	0.00	17,810.00	4,690.00
TASK 2-ENVIRONMENTAL	6,200.00	0.00	0.00	6,200.00	0.00
TASK 3-SURVEY	8,500.00	375.00	0.00	8,125.00	375.00
TASK 4-PERMITTING	24,800.00	280.00	0.00	24,520.00	280.00
Total	62,000.00	5,345.00	0.00	56,655.00	5,345.00

Task 1-Engineering Design

Professional Services

	Hours	Rate	Billed Amount
A2-Administration 2	1.00	45.00	45.00
PC2-Professional Consultant 2	29.00	95.00	2,755.00
PC5-Professional Consultant 5	13.50	140.00	1,890.00
Phase subtotal			4,690.00

Task 3-Survey

Professional Services

	Hours	Rate	Billed Amount
PC4-Professional Consultant 4	3.00	125.00	375.00

Task 4-Permitting
 Professional Services

	Hours	Rate	Billed Amount
PC5-Professional Consultant 5	2.00	140.00	280.00
Invoice total			5,345.00

Aging Summary

Invoice Number	Invoice Date	Outstanding	Current	Over 30	Over 60	Over 90	Over 120
7503	04/13/2012	2,797.50			2,797.50		
7678	06/30/2012	5,345.00	5,345.00				
	Total	8,142.50	5,345.00	0.00	2,797.50	0.00	0.00

Approved by:

Jay S. Johansen
 Project Manager

Terms : Net Due Upon Receipt

LITTLE GASPARILLA WTR UTIL INC.

3683

Knight Island Utilities, Inc.

9/20/2012

588.00

BB&T

588.00

LITTLE GASPARILLA WTR UTIL INC.

3683

Knight Island Utilities, Inc.

9/20/2012

588.00

BB&T

588.00

LMP12 M/P CHECK

51N311/39287 (471) 611161

Knight Island Utilities, Inc.

Attn: Flip
7092 Placida Road
Cape Haze, FL 33946

Invoice

Date	Invoice #
5/22/2012	24

Bill To
LITTLE GASPARILLA UTILITIES ATTN: JACK BOYER PO BOX 5159 GROVE CITY, FL 34224

Memo	Item	Class	Account #	Amount
SEE ATTACHED INVOICE FROM WOTITZKY INV 13	MISCELLANEOUS EXPENSES			462.00
			Total	
			Payments/Credits	
			Balance Due	\$462.00

WOTITZKY, WOTITZKY, ROSS & MCKINLEY
 223 TAYLOR STREET
 PUNTA GORDA, FL 33950
 941-639-2171
 EIN 65-0602770

0/4

Practicing in Personal Injury, Wrongful Death, Real Estate,
 Probate and Wills, Trusts and Estate Planning,
 Family Law and Bankruptcy

Bocilla Utilities Inc & Knight Island Utilities Inc
 Knight Island Utilities, Inc.
 Dean Beckstead
 7092 Placida Road
 Cape Haze FL 33946

Page: 1
 05/22/2012
 ACCOUNT NO: 24224-00003M
 STATEMENT NO: 13

County Interconnect

PREVIOUS BALANCE \$2,331.00

		HOURS	
04/17/2012			
MRM	Reviewing and revising letter to clients.	1.00	
04/18/2012			
MRM	Reviewing and revising letter to Mrs. Burton.	1.00	
04/27/2012			
MRM	Phone call to Mr. Beckstead, phone call to Mr. Noden.	0.60	
04/30/2012			
MRM	Phone call to Mr. Noden (2), phone call to Mrs. Burton, phone call to Mr. Beckstead.	1.20	
05/07/2012			
MRM	Phone call to Marty Burton (left message)	0.10	n/c
05/08/2012			
MRM	Phone call to Marty Burton, phone call to Dean Beckstead.	0.60	
	FOR CURRENT SERVICES RENDERED	4.40	1,320.00
05/15/2012	Administrative Expenses		66.00
	TOTAL EXPENSES		66.00
	TOTAL CURRENT WORK		1,386.00
	FINANCE CHARGE		4.60
	BALANCE DUE		<u>\$3,721.60</u>

Company: 1/3 KIU 1/3 BOCIUA
 Acct. #: _____
 Approved: [Signature]
 Total: 462.00
 Posted: _____
 Date Pd.: _____
 Chk. #: _____

LITTLE GASPARILLA WTR UTIL INC.

Knight Island Utilities, Inc.

12/19/2012

3745

63.00

BB&T

63.00

LITTLE GASPARILLA WTR UTIL INC.

Knight Island Utilities, Inc.

12/19/2012

3745

63.00

BB&T

63.00

LMP12 MP CHECK

51N311/39287 (4/11/2011)

Knight Island Utilities, Inc.

Attn: Flip
7092 Placida Road
Cape Haze, FL 33946

Invoice

Date	Invoice #
10/17/2012	30

Bill To
LITTLE GASPARILLA UTILITIES ATTN: JACK BOYER PO BOX 5159 GROVE CITY, FL 34224

			Account #
Memo	Item	Class	Amount
SEE ATTACHED INVOICE FROM WOTITZKY INV 17	MISCELLANEOUS EXPENSES		63.00
DUE UPON RECEIPT			
			Total
			Payments/Credits
			Balance Due \$63.00

WOTITZKY, WOTITZKY, ROSS & McKINLEY
 223 TAYLOR STREET
 PUNTA GORDA, FL 33950
 941-639-2171
 EIN 65-0602770

Practicing in Personal Injury, Wrongful Death, Real Estate,
 Probate and Wills, Trusts and Estate Planning,
 Family Law and Bankruptcy

Received

Bocilla Utilities Inc & Knight Island Utilities Inc
 Knight Island Utilities, Inc.
 Dean Beckstead
 7092 Placida Road
 Cape Haze FL 33946

ACCOUNT NO:
 STATEMENT NO:

Page: 1
 10/17/2012
 24224-00003M
 17

ATTN: Dean Beckstead

County Interconnect

PREVIOUS BALANCE \$1,359.23

		HOURS	
10/04/2012	MRM Phone call to Mr. Noden; phone call to Mr. Beckstead	0.60	n/c
10/11/2012	MRM Preparing for, travel to and from and attend conference with Mr. Norbert and Mr. Truex	3.00	
	FOR CURRENT SERVICES RENDERED	<u>3.00</u>	<u>180.00</u>
10/12/2012	Administrative Expenses		9.00
	TOTAL EXPENSES		<u>9.00</u>
	TOTAL CURRENT WORK		<u>189.00</u>
	FINANCE CHARGE		0.07
	BALANCE DUE		<u>\$1,548.30</u>

63⁰⁰ - 189.00

PLEASE BE ADVISED THAT WE ARE NOW ACCEPTING MASTERCARD
 & VISA CREDIT CARD PAYMENTS.
 PLEASE CONTACT OUR OFFICE FOR FURTHER DETAILS.

LITTLE GASP

Knights

L INC.
Utilities, Inc.

11/8/2012

3722

451.50

BB&T

451.50

LITTLE GASPARILLA WTR UTIL INC.

Knights Island Utilities, Inc.

11/8/2012

3722

451.50

BB&T

451.50

LMP12 M/P CHECK

51N311/39287 (4/11) 611181

Knight Island Utilities, Inc.

Attn: Flip
7092 Plácida Road
Cape Haze, FL 33946

Invoice

Date	Invoice #
9/18/2012	28

Bill To
LITTLE GASPARILLA UTILITIES ATTN: JACK BOYER PO BOX 5159 GROVE CITY, FL 34224

			Account #
Memo	Item	Class	Amount
SEE ATTACHED INVOICE FROM WOTITZKY INV 16	MISCELLANEOUS EXPENSES		451.50
DUE UPON RECEIPT			
		Total	
		Payments/Credits	
		Balance Due	\$451.50

WOTITZKY, WOTITZKY, ROSS & McKINLEY
 223 TAYLOR STREET
 PUNTA GORDA, FL 33950
 941-639-2171
 EIN 65-0602770

Practicing in Personal Injury, Wrongful Death, Real Estate,
 Probate and Wills, Trusts and Estate Planning,
 Family Law and Bankruptcy

Bocilla Utilities Inc & Knight Island Utilities Inc
 Knight Island Utilities, Inc.
 Dean Beckstead
 7092 Placida Road
 Cape Haze FL 33946

Page: 1
 09/18/2012
 ACCOUNT NO: 24224-00003M
 STATEMENT NO: 16

ATTN: Dean Beckstead

County Interconnect

PREVIOUS BALANCE \$382.66

		HOURS	
08/21/2012	MRM Phone call to Mr. Noden.	0.30	
08/24/2012	MRM Phone call to Mr. Doherty, phone call to Mr. Noden.	0.60	
08/27/2012	MRM Reviewing file, conference with Mr. Doherty.	2.20	
08/30/2012	MRM Phone call to Mrs. Burton, Esq.	0.30	
09/10/2012	MRM Phone call to Marty Burton.	0.30	
09/14/2012	MRM Phone call to C. Noden, phone call to Ken Doherty.	0.60	
	FOR CURRENT SERVICES RENDERED	4.30	1,290.00
09/14/2012	Administrative Expenses		64.50
	TOTAL EXPENSES		64.50
	TOTAL CURRENT WORK		1,354.50
08/23/2012	Payment - Knight Island Utilities, Inc.		-378.00
	FINANCE CHARGE		0.07
	BALANCE DUE		<u>1,359.23</u>

451.50 (circled) 1,354.50

Knight Island Utilities, Inc.

Attn: Flip
7092 Placida Road
Cape Haze, FL 33946

Invoice

Date	Invoice #
11/20/2012	32

Bill To
LITTLE GASPARILLA UTILITIES ATTN: JACK BOYER PO BOX 5159 GROVE CITY, FL 34224

			Account #
Memo	Item	Class	Amount
SEE ATTACHED INVOICE FROM WOTITZKY INV 18	MISCELLANEOUS EXPENSES		262.50
DUE UPON RECEIPT			
		Total	
		Payments/Credits	
		Balance Due	\$262.50



WOTITZKY, WOTITZKY, ROSS & MCKINLEY
 223 TAYLOR STREET
 PUNTA GORDA, FL 33950
 941-639-2171
 EIN 65-0602770

Practicing in Personal Injury, Wrongful Death, Real Estate,
 Probate and Wills, Trusts and Estate Planning,
 Family Law and Bankruptcy

Bocilla Utilities Inc & Knight Island Utilities Inc
 Knight Island Utilities, Inc.
 Dean Beckstead
 7092 Placida Road
 Cape Haze FL 33946

ATTN: Dean Beckstead

County Interconnect

ACCOUNT NO:
 STATEMENT NO:

Page: 1
 11/20/2012
 24224-00003M
 18

PREVIOUS BALANCE \$1,548.30

10/15/2012	MRM	Drafting memorandum to Mr. Noden	HOURS	
			2.50	
10/18/2012	MRM	Phone call from client		
		FOR CURRENT SERVICES RENDERED	2.50	750.00

*1/2 Hru.
 1/2 Bonds*

11/13/2012		Administrative Expenses		37.50
		TOTAL EXPENSES		37.50
		TOTAL CURRENT WORK		787.50

262.50

10/19/2012		Payment - Knight Island Utilities, Inc.		-1,354.50
		FINANCE CHARGE		0.58
		BALANCE DUE		<u>\$981.88</u>

Company: _____
 Accl. #: _____
 Approved: _____
 Total: _____
 Posted: _____
 Date Pd.: _____
 Ck. #: _____

PLEASE BE ADVISED THAT WE ARE NOW ACCEPTING MASTERCARD
 & VISA CREDIT CARD PAYMENTS.
 PLEASE CONTACT OUR OFFICE FOR FURTHER DETAILS.

Knight Island Utilities, Inc.

Attn: Flip
7092 Placida Road
Cape Haze, FL 33946

Invoice

Date	Invoice #
12/19/2012	34

Bill To
LITTLE GASPARILLA UTILITIES ATTN: JACK BOYER PO BOX 5159 GROVE CITY, FL 34224

			Account #
Memo	Item	Class	Amount
SEE ATTACHED INVOICE FROM WOTITZKY INV 19	MISCELLANEOUS EXPENSES		861.00
DUE UPON RECEIPT			
		Total	
		Payments/Credits	
		Balance Due	\$861.00

WOTITZKY, WOTITZKY, ROSS & MCKINLEY
 223 TAYLOR STREET
 PUNTA GORDA, FL 33950
 941-639-2171
 EIN 65-0602770

Practicing in Personal Injury, Wrongful Death, Real Estate,
 Probate and Wills, Trusts and Estate Planning,
 Family Law and Bankruptcy

^{1/3} Bocilla Utilities Inc & Knight Island Utilities Inc & KEU.
 Knight Island Utilities, Inc.
 Dean Beckstead
 7092 Placida Road
 Cape Haze FL 33946

ATTN: Dean Beckstead

County Interconnect



ACCOUNT NO:
 STATEMENT NO:

Page: 1
 12/19/2012
 24224-00003M
 19

PREVIOUS BALANCE \$981.88

		HOURS	
11/27/2012	MRM Phone call to Mr. Noden	0.30	
12/05/2012	MRM Prepare for Meeting; Review Utilities Ordinances	1.00	
12/06/2012	MRM Prepare for travel to and from and attend meeting with Messers Noden, Beckstead, Elder and Boyer	5.00	
12/10/2012	MRM Phone call to Mr. Doherty	0.30	
12/12/2012	MRM Reviewing and revising Agreement with CCU; Phone call to Mr. Noden; Phone call o Mrs. Burton's office	1.60	
	FOR CURRENT SERVICES RENDERED	8.20	2,460.00

12/14/2012	Administrative Expenses	Company: <i>Note above allocation</i>	123.00
	TOTAL EXPENSES		123.00
	TOTAL CURRENT WORK	Acct. #: <i>for and Bulk Water</i>	2,583.00

Approved:  861 ^{10/}

Total: _____ -189.00

Posted: _____ 2.77

Date Fd: _____ \$3,378.65

Chk #: _____

12/12/2012 Payment - Knight Island Utilities, Inc.

FINANCE CHARGE

BALANCE DUE

WOTITZKY, WOTITZKY, ROSS & MCKINLEY
 223 TAYLOR STREET
 PUNTA GORDA, FL 33950
 941-639-2171
 EIN 65-0602770

Practicing in Personal Injury, Wrongful Death, Real Estate,
 Probate and Wills, Trusts and Estate Planning,
 Family Law and Bankruptcy

Bocilla Utilities Inc & Knight Island Utilities Inc
 Knight Island Utilities, Inc.
 Dean Beckstead
 7092 Placida Road
 Cape Haze FL 33946

Page: 1
 06/20/2012
 ACCOUNT NO: 24224-00003M
 STATEMENT NO: 14

3000

County Interconnect

PREVIOUS BALANCE \$3,721.60

		HOURS	
05/16/2012	MRM Phone call to Mrs. Burton.	0.30	
05/17/2012	MRM Phone call to Mr. Beckstead regarding status.	0.30	
06/05/2012	MRM Phone call to Mr. Noden.	0.30	
	FOR CURRENT SERVICES RENDERED	<u>0.90</u>	<u>270.00</u>

06/15/2012 Administrative Expenses 13.50
 TOTAL EXPENSES 13.50

TOTAL CURRENT WORK 283.50

Company: _____
 Asst. # _____
 Approved: _____
 Date: _____
 Paged: _____
 Case #/ID: _____
 OK: _____

94.50

283.50

05/29/2012 Payment - Knight Island Utilities, Inc. -2,331.00

BALANCE DUE \$1,674.10

PLEASE BE ADVISED THAT WE ARE NOW ACCEPTING MASTERCARD
 & VISA CREDIT CARD PAYMENTS.
 PLEASE CONTACT OUR OFFICE FOR FURTHER DETAILS.

WOTITZKY, WOTITZKY, ROSS & MCKINLEY
 223 TAYLOR STREET
 PUNTA GORDA, FL 33950
 941-639-2171
 EIN 65-0602770
 Practicing in Personal Injury, Wrongful Death, Real Estate,
 Probate and Wills, Trusts and Estate Planning,
 Family Law and Bankruptcy

Bocilla Utilities Inc & Knight Island Utilities Inc
 Knight Island Utilities, Inc.
 Dean Beckstead
 7092 Placida Road
 Cape Haze FL 33946

Page: 1
 07/18/2012
 ACCOUNT NO: 24224-00003M
 STATEMENT NO: 15

ATTN: Dean Beckstead
 County Interconnect

KIU/Bocilla/LGI

PREVIOUS BALANCE \$1,674.10

		HOURS	
06/19/2012			
MRM	Phone call to Mr. Boyer.	0.30	
	FOR CURRENT SERVICES RENDERED	0.30	90.00

07/13/2012	Administrative Expenses		4.50
	TOTAL EXPENSES		4.50
	TOTAL CURRENT WORK		31.50 94.50

06/26/2012	Payment - Knight Island Utilities, Inc.		-1,386.00
	FINANCE CHARGE		0.06
	BALANCE DUE		\$382.66

PLEASE BE ADVISED THAT WE ARE NOW ACCEPTING MASTERCARD
 & VISA CREDIT CARD PAYMENTS.
 PLEASE CONTACT OUR OFFICE FOR FURTHER DETAILS.

4:42 PM
 05/08/14
 Accrual Basis

Little Gasparilla Utilites
Account QuickReport
 January through December 2011

Type	Date	Num	Name	Memo	Split	Amount
expansion/Bocilla Utilities						
Check	4/29/2011	3142	Dept. of Environme...	copies	BB&T	44.19 ✓
Check	5/4/2011	3143	Office Depot		BB&T	150.45
Check	8/3/2011	3366	Knight Island Utilitie...	Interconnect	BB&T	1,045.84 ✓
Check	10/5/2011	3414	Knight Island Utilitie...		BB&T	798.00 ✓
Check	11/10/2011	3438	Knight Island Utilitie...		BB&T	1,755.25 ✓
Check	12/29/2011	3467	Knight Island Utilitie...		BB&T	157.50 ✓
General Journal	12/31/2011	AJE 17		To relass-cap...	Expansion/Bo...	-3,951.23
Total expansion/Bocilla Utilities						0.00
TOTAL						0.00

LITTLE GASPARILLA WTR UTIL INC.
Knight Island Utilities, Inc.

8/3/2011

3366

1,045.84

BB&T Interconnect

1,045.84

LITTLE GASPARILLA WTR UTIL INC.
Knight Island Utilities, Inc.

8/3/2011

3366

1,045.84

BB&T Interconnect

1,045.84

LMP12 M/P CHECK

51N311/39287 (4/11) 611181

Knight Island Utilities, Inc.

Attn: Flip
7092 Placida Road
Cape Haze, FL 33946

Invoice

Date	Invoice #
7/28/2011	3

Bill To
LITTLE GASPARILLA UTILITIES ATTN: JACK BOYER PO BOX 5159 GROVE CITY, FL 34224

			Account #
Memo	Item	Class	Amount
I/3 OF ATTACHED INVOICES	MISCELLANEOUS EXPENSES		1,045.84
		Total	
		Payments/Credits	
		Balance Due	\$1,045.84

OK

LITTLE GASPARILLA WTR UTIL INC.

3414

Knight Island Utilities, Inc.

10/5/2011

798.00

BB&T

798.00

LITTLE GASPARILLA WTR UTIL INC.

3414

Knight Island Utilities, Inc.

10/5/2011

798.00

BB&T

798.00

LMP12 M/P CHECK

51N311/39287 (4/11) 611181

WOTITZKY, WOTITZKY, ROSS & MCKINLEY
 223 TAYLOR STREET
 PUNTA GORDA, FL 33950
 941-639-2171
 EIN 65-0602770
 Practicing in Personal Injury, Wrongful Death, Real Estate,
 Probate and Wills, Trusts and Estate Planning,
 Family Law and Bankruptcy

Bocilla Utilities Inc
 R. Craig Noden
 7025-A Placida Road
 Englewood FL 34224

ACCOUNT NO:
 STATEMENT NO:

Page: 1
 08/22/2011
 24224-00004M
 2

COPY

PREVIOUS BALANCE \$2,520.00

		HOURS	
07/15/2011			
MRM	Phone call to Mr. Gallagher.	0.30	
07/18/2011			
MRM	Phone call to Mr. Berntsson.	0.30	
07/19/2011			
MRM	Phone call to Trish Duffy, Craig Noden (2), Commissioner Starr.	1.20	
07/20/2011			
MRM	Phone call to Mr. Gallagher.	0.30	
07/21/2011			
MRM	Preparing for, traveling to and from and attending BOCC MSBU hearing (Tringali Center).	2.50	
07/28/2011			
MRM	Phone call to Mr. Noden, conference call with Mr. Noden & Mr. Beckstead.	0.90	
08/02/2011			
MRM	Phone call to Mr. Beckstead, phone call to Mr. Noden.	0.60	
08/05/2011			
MRM	Drafting letter to Board of Charlotte County Commissioners.	0.50	
08/08/2011			
MRM	Phone call to Mr. Noden, reviewing and revising letter.	1.00	
	FOR CURRENT SERVICES RENDERED	7.60	2,280.00
08/22/2011	Administrative Expenses		114.00
	TOTAL EXPENSES		114.00

Bocilla Utilities Inc

EAFCD

TOTAL CURRENT WORK

Page: 2

08/22/2011

ACCOUNT NO: 24224-00004M

STATEMENT NO: 2

PAY
2,394.00

LITTLE GASPARILLA WTR UTIL INC.

3467

Knight Island Utilities, Inc.

12/29/2011

157.50

BB&T

157.50

LITTLE GASPARILLA WTR UTIL INC.

3467

Knight Island Utilities, Inc.

12/29/2011

157.50

BB&T

157.50

LMP12 M/P CHECK

51N311/39287 (4-11-2011)

WOTITZKY, WOTITZKY, ROSS & McKINLEY
 223 TAYLOR STREET
 PUNTA GORDA, FL 33950
 941-639-2171
 EIN 65-0602770
 Practicing in Personal Injury, Wrongful Death, Real Estate,
 Probate and Wills, Trusts and Estate Planning,
 Family Law and Bankruptcy

Page: 1
 11/16/2011
 24224-00003M
 8

Bocilla Utilities Inc & Knight Island Utilities Inc
 Knight Island Utilities, Inc.
 Dean Beckstead
 7092 Placida Road
 Cape Haze FL 33946

ACCOUNT NO:
 STATEMENT NO:

County Interconnect

PREVIOUS BALANCE \$5,265.75

		HOURS	
10/17/2011			
MRM	Phone call to Mr. Skidmore, phone call to Mrs. Couture, phone call to Mr. Noden	0.90	
11/01/2011			
MRM	Send email to Mrs. Couture, phone call to Mr. Noden.	0.60	
	FOR CURRENT SERVICES RENDERED	1.50	450.00

11/15/2011	Administrative Expenses	22.50	
	TOTAL EXPENSES	22.50	
	TOTAL CURRENT WORK		472.50
	BALANCE DUE		<u>\$5,738.25</u>

624.03 - 157.50
 3999 - 157.50
 3999 - 157.50
 Bocilla
 Little
 GAPP

S/ KIU - 1/3 Bocilla
 1/3 L. Gasparilla
 1/3 KIU.



PLEASE BE ADVISED THAT WE ARE NOW ACCEPTING MASTERCARD
 & VISA CREDIT CARD PAYMENTS.
 PLEASE CONTACT OUR OFFICE FOR FURTHER DETAILS.

LITTLE GASPARILLA WTR UTIL INC.

3438

Knight Island Utilities, Inc.

11/10/2011

1,755.25

BB&T

1,755.25

LITTLE GASPARILLA WTR UTIL INC.

3438

Knight Island Utilities, Inc.

11/10/2011

1,755.25

BB&T

1,755.25

LMP12 M/P CHECK

51N311/39287 (4-11) 511161

Knight Island Utilities, Inc.

Attn: Flip
7092 Placida Road
Cape Haze, FL 33946

Invoice

Date	Invoice #
10/20/2011	6

Bill To
LITTLE GASPARILLA UTILITIES ATTN: JACK BOYER PO BOX 5159 GROVE CITY, FL 34224

			Account #
Memo	Item	Class	Amount
SEE ATTACHED INVOICE FROM WOTITZKY INV 7	MISCELLANEOUS EXPENSES		1,755.25
		Total	
		Payments/Credits	
		Balance Due	\$1,755.25

WOTITZKY, WOTITZKY, ROSS & McKINLEY
 223 TAYLOR STREET
 PUNTA GORDA, FL 33950
 941-639-2171
 EIN 65-0602770
 Practicing in Personal Injury, Wrongful Death, Real Estate,
 Probate and Wills, Trusts and Estate Planning,
 Family Law and Bankruptcy

Bocilla Utilities Inc & Knight Island Utilities Inc
 Knight Island Utilities, Inc.
 Dean Beckstead
 7092 Placida Road
 Cape Haze FL 33946

ACCOUNT NO:
 STATEMENT NO:

Page: 1
 10/20/2011
 24224-00003M
 7

County Interconnect

			HOURS
08/15/2011	MRM	Office conference with Mr. Noden.	0.30
08/25/2011	MRM	Prepare for, travel to and from and attend meeting with Messrs. Beckstead and Noden.	3.00
08/26/2011	MRM	Drafting letter to Englewood Water District.	1.00
08/29/2011	MRM	Reviewing and reviewing letter to Englewood Water District, phone call to Mr. Noden.	0.80
08/30/2011	MRM	Phone call to Mr. Noden, phone call to Mr. Boyer, revising letter to Englewood Water District.	1.20
09/06/2011	MRM	Phone call to Mr. Berntsson, Esq.; phone call to Mr. Noden	0.60
10/03/2011	MRM	Phone call to Mr. Riley, phone call to Mr. Noden.	0.60
10/05/2011	MRM	Phone call to Mr. Noden, phone call to Attorney Berntsson, prepare for Englewood Water District meeting.	1.80
	CY	Researching law regarding access through another entity's certificated area	0.50
10/06/2011	MRM	Prepare for, travel to and from and attend Englewood Water District meeting.	3.00
10/07/2011	MRM	Reviewing correspondence from Ms. Burton, phone calls to Ms. Burton and Mr. Noden.	1.20

County Interconnect

		HOURS	
10/10/2011	MRM	Phone call from Attorney Marty Burton. Phone calls to Mr. Berntsson, Mrs. Couture, and Mr. Noden.	1.20
10/11/2011	MRM	Phone call to Mr. Noden, review letter from Mr. Berntsson.	1.30
10/14/2011	MRM	Phone call to Craig Noden.	0.30
		FOR CURRENT SERVICES RENDERED	16.80
			<u>5,015.00</u>
10/14/2011		Administrative Expenses	250.75
		TOTAL EXPENSES	<u>250.75</u>
		TOTAL CURRENT WORK	5,265.75
		BALANCE DUE	<u>\$5,265.75</u>

PLEASE BE ADVISED THAT WE ARE NOW ACCEPTING MASTERCARD
& VISA CREDIT CARD PAYMENTS.
PLEASE CONTACT OUR OFFICE FOR FURTHER DETAILS.



Florida Department of Environmental Protection

South District
P.O. Box 2549
Fort Myers, Florida 33902-2549

Rick Scott
Governor

Jennifer Carroll
Lt. Governor

Herschel E. Vinyard Jr.
Secretary

PHOTOCOPY QUOTE

Please Make Checks Payable to Florida Dept. of Environmental Protection

Requested by: Jack Boyer Date Requested: 4/29/11

Telephone: 941-626-8294

Fax#: _____

Email Address: Lwjd777@yahoo.com

File Name and/or description: Bocilla Utilities (permit 08-0128651-001 & easement 41234)

Photocopies Made by: Jeannie 239-344-5645

Number of Pages 161 = \$ 24.15
(Single-sided @ 15 cents per copy)

Number of Pages 52 = \$ 10.04
(Double-sided @ 20 cents per copy or
8 1/2 x 14 paper)

Maps = \$ _____
(30"x42" = \$0.30 per sheet;
36"x30" = \$0.50 per sheet)

CD-ROM = \$ _____
(disk w/sleeve) = \$0.70 per disk

Certified copy of a record - \$1.00 per certification provided for each record = \$ _____

Clerical Assistance (Staff Time on Assignment): _____ = \$ 10.00

Additional Fees (Postage): _____ = \$ _____

TOTAL COST FOR PHOTOCOPY ASSIGNMENT: \$ 44.19

Check Number: 3142
Date: 4/29/11



23/a

Estimate

Customer Name and Address
Little Gasparilla Water Utilities PO Box 5159 Grove City, FL 34224 RE: Intra- Coastal Drill

Date	#
5/7/2014	1016

Project Name

Description of Work	Quantity	U/M	Subcontractor	Unit Cost	Total	
DR 9 DIPS 8"	3,500		<i>Not Confirmed yet</i>	135.00	472,500.00	
6" Meter and Backflow Assembly (cost of meter not known)	1			25,000.00	25,000.00	
Silt Fence and barriers	1,400			4.00	5,600.00	
Surveying	1			5,000.00	5,000.00	
Testing	1			5,000.00	5,000.00	
Asphalt repair and sod	1			25,000.00	25,000.00	
Auto Air Valve	1			4,000.00	4,000.00	
Manual Air Release Valve and Sample Points	5			1,000.00	5,000.00	
6" HDEP 11	100			35.00	3,500.00	
8" Gate Valve	1			1,800.00	1,800.00	
8"x8" Tee	1			800.00	800.00	
6" C-900 dr18	1,900			25.00	47,500.00	
6" tee with restrainer	2		<i>69,550.00 Line North</i>	750.00	1,500.00	
6" 90 bend with restrainer	9			600.00	5,400.00	
6" Valve	3			950.00	2,850.00	
6" 45 Bends	2			600.00	1,200.00	
Connect to Existing Hydrant	1			1,500.00	1,500.00	
6" Solid Sleeve	1			600.00	600.00	
Hydrant Assy	1			4,800.00	4,800.00	
2" poly	100			15.00	1,500.00	
2" valve	2			350.00	700.00	
Barge Fees and mobilization					12,000.00	12,000.00

	Total	\$632,750.00
--	--------------	--------------

Signature

*69,550.00
563,200.00*

\$612,000
Just the Drill

#230B

Charlie Whippo

From: "Marty Adams" <madams@tblandmark.com>
Date: Thursday, May 08, 2014 7:45 AM
To: <whippoco@gmail.com>
Subject: 3500' 8" HDD

Charlie,

It looks like this drill shot is going to run between \$175/ LF to \$214 / LF. 8" DR-9 might not be strong enough to handle this drill.

Hope this helps,

Marty Adams
Manager
TB Landmark Construction
904-503-5705 Direct Line
904-591-5801 cell
904-751-4125 fax

"The quality of a person's life is in direct proportion to their commitment to excellence, regardless of their chosen field of endeavor."—Vince Lombardi



23
If Booster Pumps are
required

Estimate

Customer Name and Address
Little Gasparilla Water Utilities PO Box 5159 Grove City, FL 34224 Re: Booster Pump

Date	#
5/13/2014	1020

Project Name

Description of Work	Quantity	U/M	Subcontractor	Unit Cost	Total
Booster Pump				0.00	0.00
Sencillo Model V VFD Duel Pump System. 240v 3ph, 350 gpm@ 146 ft. DTH each pump	1			50,000.00	50,000.00
Barge Fees	2			600.00	1,200.00

Final pricing can be made after Engineering

Total \$51,200.00

Signature _____



610-358-8106
sales@sencillosystems.com
[Distributor Log-In](#)
[Join Our Mailing List](#)

HOME ABOUT US PRODUCTS CONTROL PANELS APPLICATIONS PORTFOLIO SUPPORT BLOG CONTACT

SENCILLO™ P

The Sencillo™ P is the entry level low cost version of simplex and duplex pumping systems, designed for limited budgets. It is typically used on smaller, less critical applications, and includes totally automatic controls.

- Economical model for smaller budgets
- Smaller Black and white touch screen controller
- Flows to 400 gpm, pressures to 80 psi.
- 5" Monochrome HMI
- Simplex or Duplex

Document Downloads

- [Specifications for Sencillo P Variable Speed Systems »](#)
- [Specifications for Sencillo P Wall-Mounted Variable Speed Systems »](#)



Need Pricing?

- Call Us With Your Specs: 610-358-8106
- Email Your Specs to the [Sencillo™ Pricing Center](#)
- Fax Your Specs to 610-358-8109

SYSTEM TYPE SELECTION CHART

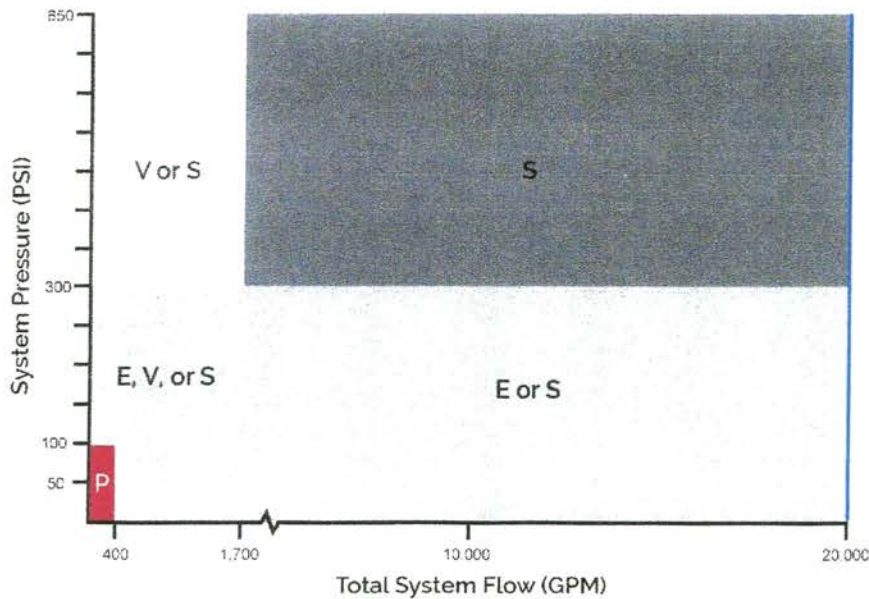



Home Control Panels
 About Us Applications
 Products Portfolio
 Sencillo™ E Support
 Sencillo™ V Size a System
 Sencillo™ S Contact
 Sencillo™ P Site Map
 Retrofit Kit Privacy Policy

Copyright © 2014
 All Rights Reserved

sales@sencillosystems.com
 Tel: 610-358-8106
 Fax: 610-358-8109

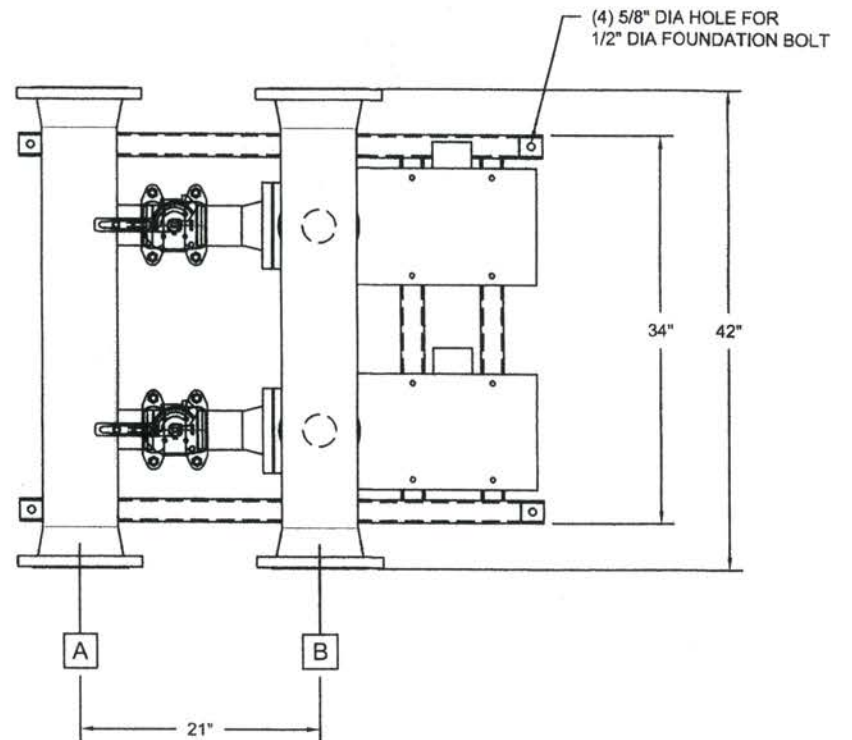
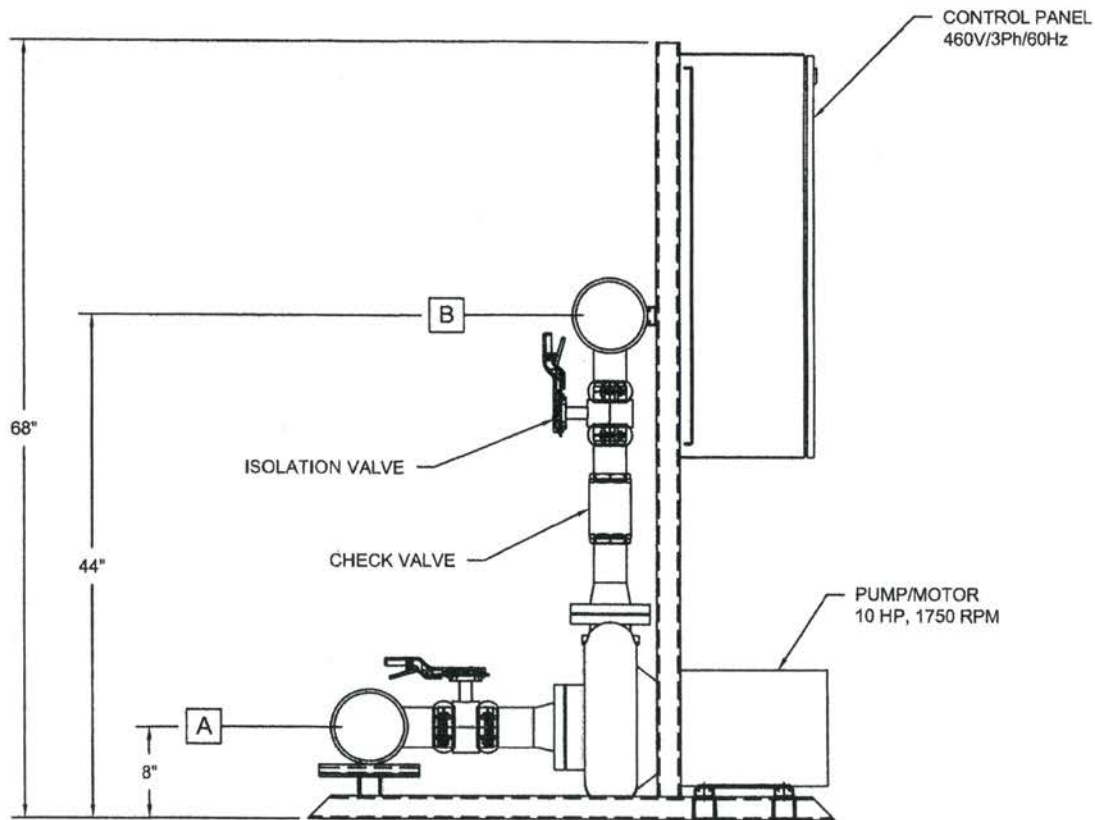
Sencillo™ Systems
 6-D Mount Pleasant Road
 Aston, PA 19014

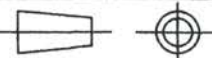

2								
1								
0		01/13/14	JEC				ORIGINAL ISSUE	
REV.	E.R. NO.	DATE	BY	CKD	APRD	DESCRIPTION		
SCALE		JOB NO.	ASSEMBLY	 SENCILLO SYSTEMS 6D MOUNT PLEASANT RD ASTON, PA 19014 TEL: (610) 358-8106			GENERAL ARRANGEMENT	
1"=12"	JC-0703							
		WEIGHT (LBS)		UNLESS OTHERWISE SPECIFIED ALL DIMENSIONS ARE IN INCHES BREAK CORNERS - .015" INSIDE CORNERS - .015" MACHINED SURFACES - 65 RMS CONCENTRICITY - .010" TIR			FRACTIONAL ± 1/8" DECIMAL X.XX ± 0.03 X.XXX ± 0.010 ANGULAR TOL. ± 0.5°	
THIS DRAWING AND ALL INFORMATION THEREON IS THE PROPERTY OF SENCILLO SYSTEMS. ALL INFORMATION ON THIS DRAWING IS STRICTLY CONFIDENTIAL, AND SHALL NOT BE DISCLOSED TO THIRD PARTIES WITHOUT WRITTEN AUTHORIZATION OF SENCILLO SYSTEMS.				TITLE		DWG. NO. B0703-100 SHEET 1 OF 1		

#236-1

Estimate

Hoot Gibson Construction Co
P.O. Box 733
Placida, FL 33946

Date 5/14/2014
Estimate # 68

Name / Address

Little gasparilla Water
P.O. Box 5149
Grove City Fl 34224
Rehab Existing Pumping Station

P.O. #

Terms

Due Date 5/14/2014

Other

Description	Qty	Rate	Total
Charlotte County Permit & Impact Fees		6,300.00	6,300.00
Engineering--Surveys, Fema Certs		3,900.00	3,900.00
Demolition		35,000.00	35,000.00
Transportation--Parking--Material Barging		18,000.00	18,000.00
Building System Using SiP Panels system by New Panel Homes LLC.		90,000.00	90,000.00
General Materials/Stairs & Rail		15,000.00	15,000.00
Genral Labor		48,000.00	48,000.00
Roofing System (Metal)		12,000.00	12,000.00
Doors & Windows		13,000.00	13,000.00
Electrical & Service Equipment		48,000.00	48,000.00
Interior/Exterior Water Proofing & Paint		12,000.00	12,000.00
Waste Water Lift Station		2,500.00	2,500.00
H.V.A.C. System		8,000.00	8,000.00
Temp Facilities/Equipment Rental		4,500.00	4,500.00
Contractors Profit/Overhead 15%		47,430.00	47,430.00
		Subtotal	\$363,630.00
		Sales Tax (0.0%)	\$0.00
		Total	\$363,630.00

Hoot Gibson Construction Co
hootgibson@embarqmail.com
www.hootgibsonconstruction.com

941-270-1506
Fax 941-698-1117

23 b-2

Brian C. Bishop and Associates, Inc



NEW PANEL HOMES INC.
512 PAUL MORRIS DRIVE - ENGLEWOOD, FL 34223
PHONE 941.475.6300 - FAX 941.475-6311
www.newpanelhomes.com

May 14, 2014

Project: Replacement Water Plant Building, Little Gasparilla Island, Florida

Dear Mr. Boyer,

Thank you for the invitation to bid removing and replacing your existing water plant building. The new building will be placed on top of the existing concrete tank. Our firm has been in operation for more than 30 years in Southwest Florida and are familiar with the 2010 Florida Building Code and construction in high wind / flood zone areas.

Included in this proposal is the following work:

1. All engineered construction documents suitable for review by Charlotte County, Florida Building Department.
2. Elevation Certificates as required.
3. Demolition of existing building.
4. All electrical and plumbing utility work.
5. Concrete installation and demolition as required.
6. Construction of insulated building shell with James Hardie siding at exterior.
7. All plumbing required for 3 fixture bathroom.
8. Interior framing and finishing trim.
9. All decks and stairways.
10. Installation of metal roof, designed to meet required wind zone.
11. Doors and windows all large missile impact.
12. Painting and landscaping to make building compatible with neighboring homes.
13. Haul all debris off the island and dispose of in lawful manner.
14. Administration of project through Certificate of Occupancy.

This proposal is for all labor, equipment, and materials required for the work including barge transportation. Any questions feel free to contact me.

Total cost for this proposal \$361,000.00

Yours Truly,

Brian C. Bishop, CBC032004

A handwritten signature in black ink, appearing to read "Bee", is written over the typed name and ID number.

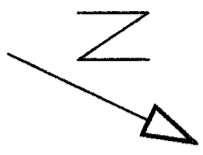

FLOOR PLAN

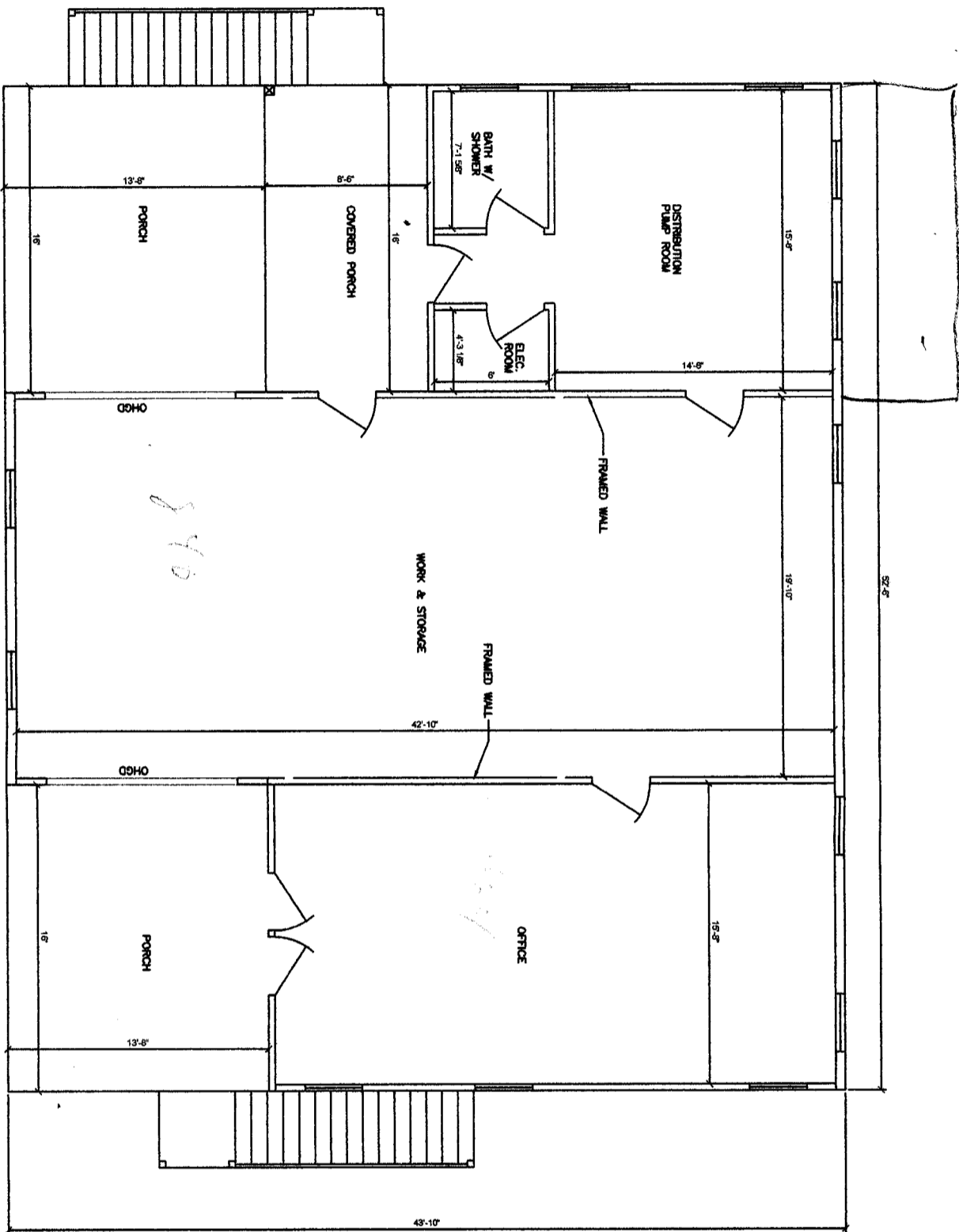

SCALE: 1/8" = 1'-0"
A.2.2
DATE: 3/15/12

NO.	REVISIONS

JACK & DIANE BOYER
LITTLE GASPARILLA
PLACIDA, FL



512 Paul Morris Drive
Englewood, FL 34223
Phone: 941-475-8300 Cell 941-915-3090
www.newpanelhomes.com



1532 US HWY 41 BYP S 8154
VENICE FLORIDA
941-451-8971 34293
EMAIL: axisengr@gmail.com

C OF A 27860
BERNARD H. POWELL, II, P.E. No. 53921
ENGINEER OF RECORD
DATE:

1. GENERAL NOTES

- 1.1 FBC REFERS TO 2010 FLORIDA BUILDING CODE.
- 1.2 FBC-R REFERS TO 2010 FLORIDA BUILDING CODE.
- 1.3 COMPACT BACK FILL 5'-0" FROM STRUCTURE. MINIMUM ALLOWABLE BEARING CAPACITY SHALL BE 2000 PSF.
- 1.4 CONTRACTOR TO VERIFY MANUFACTURED TRUSS PLAN PRIOR TO PLACEMENT OF STEELWALL OR MONOLITHIC FOOTING.
- 1.5 PLUMBER IS TO INFORM SUPERINTENDENT OF ANY VENTING WHICH UTILIZES A MASONRY WALL TO RESOLVE ANY POSSIBLE STRUCTURAL INTEGRITY ISSUES.

2. CONCRETE/MASONRY NOTES

- 2.1 ALL CONCRETE SHALL BE $F_c=3000$ PSI.
- 2.2 MASONRY SHALL USE TYPE S MORTAR.
- 2.3 REINFORCING STEEL SHALL SATISFY ASTM A615, 60. FOOTING MAY USE 60 40 STEEL.
- 2.4 WHERE INDICATED ON FLOOR PLANS, PROVIDE CONCRETE FILLED CELL WITH REINFORCING STEEL FROM FOOTING TO THE BEAM HOOKED & TIED BEFORE INSPECTION. IF GROUT LIFT EXCEEDS 4'-0", AN INSPECTION HOLE TO VERIFY GROUTING SHALL BE PROVIDED AT THE BOTTOM CELL.
- 2.5 PROVIDE (1) #5 VERTICAL REINFORCING STEEL ELECTRICAL GROUND TO FOUNDATION STEEL.
- 2.6 ALL FOOTINGS TO BE SMOOTH AND LEVEL.
- 2.7 REINFORCING STEEL LAP LENGTH IN CONCRETE SHALL BE:
#5 REBAR -30"
#6 REBAR -36"
#7 REBAR -45"
- 2.8 MINIMUM CONCRETE COVER 1 1/2" UNLESS NOTED OTHERWISE. MAXIMUM CONCRETE COVER 6" UNLESS NOTED OTHERWISE.
- 2.9 EMBEDDED ANCHORS/TIEDOWNS SHALL HAVE MIN 2" COVER.

3. FRAMING NOTES

- 3.1 ALL DOOR HEADERS AT BEARING WALLS TO BE (2) 2X10 SYP OR BETTER, UNLESS NOTED OTHERWISE.
- 3.2 EXTERIOR FRAME WALLS, BEARING OR NON BEARING, SHALL BE SHEATHED WITH 5/8" PLYWOOD OR EQUAL, BLOCKED, NAILED WITH 10d AT 4" O.C. EDGES, 8" O.C. FIELD.
- 3.3 BEAMS SHALL BEAR DIRECTLY ON PSL OR SYP POSTS U.N.O. WHERE REQUIRED, SHIMS TO BE A36 STEEL U.N.O.
- 3.4 PSL OR SYP POSTS SHALL BEAR DIRECTLY ON CONCRETE SLAB OR ON SYP OR PT PLATE UNLESS NOTED OTHERWISE.

4. WOOD NOTES

- 4.1 PSL: 1.8E PARALLEL STRAND LUMBER, $F_b=2400$ psi
- 4.2 LV: 1.9E LAMINATED VENEER LUMBER, $F_b=2600$ psi
- 4.3 PT: PRESSURE TREATED SOUTHERN PINE #2 GRADE OR BETTER
- 4.4 SPF: SPRUCE PINE FIR #2 GRADE OR BETTER
- 4.5 SYP: SOUTHERN YELLOW PINE #2 GRADE OR BETTER

5. WALL PANEL NOTES

- 5.1 WALL PANELS (TYP): 4" OSB
- 5.10 WALL PANELS (WHERE INDICATED): 6" OSB PANELS
- 5.2 TYPICAL PANEL SIZE: 4'xLENGTH REQ'D
- 5.3 EXTERIOR AND INTERIOR SKIN: OSB
- 5.4 CORE MATERIAL: 3", 5", OR 7 1/2" THICK, 1.0 PCF EXPANDED POLYSTYRENE (EPS) FOAM
- 5.5 ADHESIVE: MOR-AD M650 SERIES BY ROHM AND HAAS. STRUCTURAL DESIGN OF PANELS IS FOR LOAD RESISTANCE ONLY. WATERPROOFING AND SEALING OF PANELS IS THE RESPONSIBILITY OF THE BUILDER.
- 5.6 ALL PANEL WALLS ACT AS SHEAR WALLS.
- 5.7 DOUBLE TOP PLATES SHALL BE PT AND JOINED SUCH THAT MINIMUM OVERLAP IS 16". PLATES ATTACHED WITH 16d OR #12x3" LONG SCREWS AT 16" O.C., MINIMUM (4) 16d OR #12x3" LONG BETWEEN SPLICES, U.N.O. FOR GABLE END WALLS, USE ADVANTECH SHEATHING 5/8" INSIDE & OUTSIDE SKIN THICKNESS.

6. ROOF FRAMING NOTES

- 6.1 THE DESIGN OF ROOF FRAMING SHALL BE BASED ON THE REQUIREMENTS OF THE FBC-R.
- 6.2 DESIGN WIND LOADS SHALL BE APPLIED IN ACCORDANCE WITH FBC SECTION 1609. SEE WIND NOTES FOR WIND DESIGN REQUIREMENTS.
- 6.3 ROOF TRUSS MANUFACTURER SHALL SUBMIT AND PROVIDE COMPLETE LAYOUT AND FURNISH THE FOLLOWING INFORMATION: ROOF PITCH, LUMBER SIZE, SPACING, SPICES AND BRACING, LOCATION AND MAGNITUDE OF UPLIFT LOADS.
- 6.4 PRE-ENGINEERED TRUSS DESIGN SHALL BE SIGNED AND SEALED BY A FLORIDA LICENSED PROFESSIONAL ENGINEER.
- 6.5 ROOF SHEATHING SHALL BE 5/8" CD PLYWOOD OR EQUAL, FASTENED WITH 8d RING-SHANK NAILS AT 4" O.C. EDGES AND 8" O.C. FIELD U.N.O. NAILING SHALL BE AT 4" O.C. EDGES AND FIELD WITHIN 4'-0" OF RIDGES AND EDGES OF ROOF AND 3" O.C. WITHIN 4'-0" OF EXTERIOR ROOF CORNERS.
- 6.6 CONTRACTORS SHALL VERIFY WITH ROOF TRUSS PLAN PRIOR TO PLACEMENT OF FOOTINGS.

7. GARAGE NOTES

- 7.1 OPENINGS FROM GARAGE INTO LIVING SPACE OF RESIDENCE SHALL MEET THE REQUIREMENTS OF FBC SECTION R302.5.1.
- 7.2 DUCTS IN THE GARAGE AND DUCTS PENETRATING THE WALLS OR CEILINGS SEPARATING THE DWELLING FROM THE GARAGE SHALL MEET THE REQUIREMENTS OF FBC SECTION R302.5.2.
- 7.3 GARAGE AND LIVING SPACE SEPARATION SHALL MEET THE REQUIREMENTS OF FBC SECTION R302.6.
- 7.4 GARAGE DOORS SHALL SATISFY THE REQUIREMENTS OF FBC FOR WIND LOADS AS DEFINED IN ROOF FRAMING AND WIND NOTES.

9. DESIGN LOADS AND NOTES

- 9.1 ROOF TRUSSES - D+L
55PSF W/ 1.33 STRESS INCREASE FACTOR, OR 45PSF W/ 1.25 STRESS INCREASE FACTOR, OR 41PSF W/ 1.00 STRESS INCREASE FACTOR.
- 9.2 FLOOR - D+L
85PSF W/ 1.00 STRESS INCREASE FACTOR.
- 9.3 DL = 10PSF IN COMBINATION WITH WIND LOADS.
- 9.4 MEAN ROOF HEIGHT SHALL BE DETERMINED BY CONTRACTOR.
- 9.5 LATERAL LOADS AT TOP OF EXTERIOR WALLS SHALL BE BASED ON 25 PSF ON WALL.
- 9.6 LATERAL LOADS IN TRUSSES ARE RESISTED BY ROOF DIAPHRAGM AT POINT OF WIND LOAD INPUT U.N.O.
- 9.7 TRUSS MANUFACTURER'S TRUSS LAYOUT SHALL SHOW ALL CONNECTIONS BETWEEN TRUSSES AND OTHER TRUSSES AND BETWEEN TRUSSES AND WOOD BEAMS. TRUSSES MUST BE DESIGNED TO SUPPORT WALLS AGAINST OUT-OF-PLANE LOADS IN ACCORDANCE WITH ITEM 9.5. THIS APPLIES TO ALL TRUSSES WITH A RAISED HEEL CONDITION THAT BEAR ON AN EXTERIOR WALLS.
- 9.8 NO PROVISION HAS BEEN MADE IN THE STRUCTURAL DESIGN FOR TEMPORARY CONDITIONS OCCURRING DURING CONSTRUCTION, UNLESS SPECIFICALLY NOTED ON THE STRUCTURAL DRAWINGS. THE CONTRACTOR SHALL PROVIDE ALL NECESSARY SHORING AND BRACING REQUIRED TO RESIST STRESSES OR INSTABILITY OCCURRING FROM ANY CAUSE DURING CONSTRUCTION. THE CONTRACTOR SHALL ASSUME COMPLETE RESPONSIBILITY FOR SUCH MEASURES.

DESIGN LOAD CRITERIA

Wind = 124 MPH (180 MPH WUB)

- A. BASIC WIND SPEED, V_{100} = 124 MPH (180 MPH WUB)
- B. IMPORTANCE FACTOR = 1.0 (RISK CATEGORY II)
- C. ENCLASURE CATEGORY = ENCLOSED BLDG.
- D. EXPOSURE CATEGORY = B
- E. INTERNAL PRESSURE COEFF. = +0.15
- F. ROOF PRESSURE (GIRTS) = +0.1 & -14.5 PSF
- G. LATERAL WALL PRESSURE (GIRTS) = +12.8 & -14.8 PSF
- H. MAX. COMP. & CLADDING (DOOR/WINDOW) = +15.8 & -48.2 PSF (ZONE 3)
- I. MAX. COMP. & CLADDING (DOOR/WINDOW) = +17.7 & -57.9 PSF
- J. USE MINOR RESISTANT WINDOWS & DOORS
- K. LIVELOADS: ROOF DL: WALL DL: CEILING DL: FLOOR DL:
FLOOR-PSF: 2.0 PSF (2.0 PSF) 2.0 PSF 2.0 PSF 2.0 PSF
ROOF-PSF: 8d+12 PSF 8d+12 PSF

ALLOWABLE WIND LOAD SCHEDULE
EXPOSURE B - FULLY ENCLOSED - $h \leq 30'$

SCHEDULE OF COMPONENTS & CLADDING LOADS
Wind = 124 MPH (180 MPH WUB)

ZONE	TRIBUTARY AREA (S.F.)	IN (PRESSURE) PSF	OUT (SUCTION) S.F.
4	10 OR LESS	27.7	-30.0
	MORE THAN 10 TO 20	26.5	-29.8
	MORE THAN 20 TO 50	25.3	-27.4
	MORE THAN 50 TO 100	24.1	-26.5
5	MORE THAN 100	23.0	-25.3
	10 OR LESS	27.7	-37.0
	MORE THAN 10 TO 20	26.5	-35.6
	MORE THAN 20 TO 50	25.3	-27.9
5	MORE THAN 50 TO 100	24.1	-26.7
	MORE THAN 100	23.0	-25.3

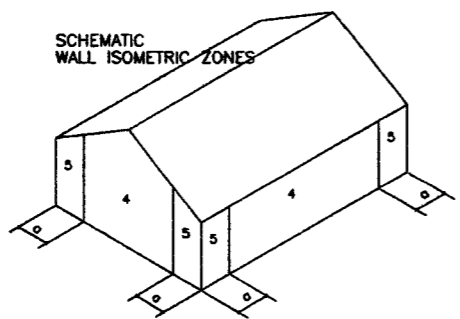

8. PEST/DECAY PROTECTION NOTES

- 8.1 ALL PLANTINGS AND IRRIGATION/SPRINKLER SYSTEMS AND RISERS FOR SPRAY HEADS SHALL BE AT LEAST 1'-0" FROM BUILDING SIDEWALLS.
- 8.2 IN WALL PEST TUBING AND BORA CARE TREATMENT ON ALL INTERIOR WOOD PROVIDES SUBTERRANEAN TERMITES ABATEMENT AS WELL AS PROTECTION AGAINST WOOD DESTROYING ORGANISMS.
- 8.3 WOOD GRADE STAKES SHALL NOT BE USED.
- 8.4 PROTECTION AGAINST DECAY AND TERMITES SHALL BE PROVIDED IN ACCORDANCE WITH FBC SECTIONS R317 AND R318.
- 8.5 ROOF FLASHING SHALL BE PROVIDED IN ACCORDANCE WITH THE REQUIREMENTS OF FBC SECTIONS R703.7.5, R703.8, R903.2 AND R905.

10. GENERAL CONNECTIONS NOTES

- 10.1 CONNECTIONS SHOWN ARE RECOMMENDED, BUT OTHER CONNECTIONS MAY BE SUBSTITUTED AS LONG AS THEY MEET OR EXCEED UPLIFTS AND LATERAL CAPACITY OF THE ANCHORS SPECIFIED AND SATISFY TRUSS LAYOUT REQUIREMENTS COMPLIANCE WITH USP, SIMPSON OR OTHER MANUFACTURER'S REQUIREMENTS.
- 10.2 FOR ADDITIONAL TIE DOWN INFORMATION, SEE SIMPSON OR USP CATALOGS.
- 10.3 FOR POST-INSTALLED ANCHORS: HOLE PREPARATION, CARTRIDGE PREPARATION, AND EPOXY FILLING SHALL BE PERFORMED PER MANUFACTURER'S ADHESIVE ANCHOR INSTALLATION INSTRUCTIONS.
- 10.4 AN EPOXY INSPECTION MAY BE REQUIRED DEPENDING ON JURISDICTION. CONTRACTOR MUST VERIFY.

POST UPLIFT ANCHORS - MASONRY/CONCRETE

POST ANCHORS TO MASONRY OR CONCRETE SHALL BE AS FOLLOWS (REFER TO SIMPSON 2009-2010 CATALOG #C-2009) OTHER BRANDS OF CONNECTORS MAY BE SUBSTITUTED IF BOTH UPLIFT AND LATERAL LOAD CAPACITIES ARE EQUAL OR GREATER THAN CONNECTORS SPECIFIED

MINIMUM POST THICKNESS	NOMINAL UPLIFT CAPACITY FOR SYP OR BTR	CONNECTOR TYPE	FASTENER TO POST FOR NOMINAL UPLIFT	ANCHOR BOLT DIAMETER
1 1/2"	1310#	SIMPSON LTT19	(8) 10d x 1 1/2" LONG NAILS	1/2", 3/4" OR 1"
	1350#	SIMPSON LTT131	(18) 10d x 1 1/2" LONG NAILS	1"
	3610#	SIMPSON HTT4	(18) 10d x 1 1/2" LONG NAILS	1"
	4350#	SIMPSON HTT5	(26) 10d x 1 1/2" LONG NAILS	1"
2"	2405#	SIMPSON HD5	(2) 3/4" DIAM STUD BOLTS	1" OR 1 1/2"
	3955#	SIMPSON HTT16	(18) 16d x 2" LONG NAILS	1"
	4235#	SIMPSON HTT4	(18) 16d x 2" LONG NAILS	1"
2 1/2"	5090#	SIMPSON HTT5	(26) 16d x 2" LONG NAILS	1"
	3835#	SIMPSON HD5	(2) 3/4" DIAM STUD BOLTS	1" OR 1 1/2"
3"	4165#	SIMPSON HTT22	(32) 10d NAILS	1"
	4670#	SIMPSON HTT5	(26) 10d NAILS	1"
3 1/2"	6480#	SIMPSON HD5	(3) 3/4" DIAM STUD BOLTS	1" OR 1 1/2"
	5010#	SIMPSON HD5	(2) 3/4" DIAM STUD BOLTS	1"
	6480#	SIMPSON HD7	(3) 3/4" DIAM STUD BOLTS	1" OR 1 1/2"
	10330#	SIMPSON HD9	(3) 1" DIAM STUD BOLTS	1" OR 1 1/2"
11350#	SIMPSON HD12	(4) 1" DIAM STUD BOLTS	1"	

- NOTES**
- 1/2" DIAMETER A307 ALL THREAD SET IN 3/4" DIAMETER HOLE W/ SIMPSON SET EPOXY, MIN EMBED 5"
 - 3/4" DIAMETER A307 ALL THREAD SET IN 1" DIAMETER HOLE W/ SIMPSON SET EPOXY, MIN EMBED 8"
 - 1" DIAMETER A307 ALL THREAD SET IN 1 1/2" DIAMETER HOLE W/ SIMPSON SET OR EQUAL, MIN EMBED 8".
 - 1 1/2" DIAMETER A307 ALL THREAD SET IN 1 3/4" DIAMETER HOLE W/ SIMPSON SET OR EQUAL, MIN EMBED 9".

MULTIPLE MEMBER CONNECTIONS FOR 1.9E MICROLAM LVL BEAMS

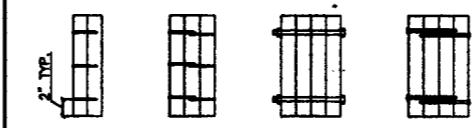

- 2 PIECES - 1 1/2" WIDE:
 - MINIMUM (2) ROWS OF 12d NAILS AT 12" O.C. FOR MEMBERS LESS THAN 14" DEEP
 - MINIMUM (3) ROWS OF 12d NAILS AT 12" O.C. FOR MEMBERS GREATER THAN 14" DEEP
- 3 PIECES - 1 1/2" WIDE:
 - (3) ROWS OF 12d NAILS AT 12" O.C.; OR
 - (2) ROWS OF 3/4" BOLTS AT 12" O.C.; OR
 - (2) ROWS OF 1/2" x 3 1/2" LAG SCREWS AT 12" O.C.
- 4 PIECES - 1 1/2" WIDE:
 - (2) ROWS OF 3/4" BOLTS AT 12" O.C.; OR
 - (2) ROWS OF 1/2" x 3 1/2" LAG SCREWS AT 12" O.C.

- GENERAL NOTES:**
- A307 BOLTS WITH WASHERS REQUIRED. BOLT HOLES TO BE 1/16" MAXIMUM.
 - SCREWS MUST HAVE SELF-DRILLING TIP AND MINIMUM BENDING YIELD STRENGTH OF 217,000PSI.
 - 6" LONG SCREWS REQUIRED.
 - CONNECTION INSTRUCTIONS ON PLAN SUPERSEDE PRECEDING.

11. TRUSS TO FRAME CONNECTION NOTES

- 11.1 ROOF TRUSSES: USE SIMPSON H10 OR H10-2 AT EACH TRUSS WHERE POSSIBLE. PROVIDE ADDITIONAL TIE-DOWNS FOR UPLIFTS IN EXCESS OF GIVEN ALLOWABLE VALUES. WHERE H10 OR H10-2 CANNOT BE USED (E.G. 3-PLY GIRDERS, CORNERS, ETC.) USE SIMPSON H2.5 PLUS ADDITIONAL TIE-DOWNS AS REQUIRED TO MEET UPLIFT LOADS.
- 11.2 FLOOR TRUSSES: USE SIMPSON 2.5 AT EACH TRUSS (WITH OR WITHOUT UPLIFT) WHERE POSSIBLE. PROVIDE ADDITIONAL TIE-DOWNS AS REQUIRED TO MEET UPLIFT LOADS.

12. EXTERIOR CEILINGS NOTES

- 12.1 ENTRY/LAMA/CABANA CEILINGS (AREAS EXPOSED TO WIND): PROVIDE 2X4 BLOCKING AT 48" O.C. AT THE BOTTOM CHORD OF ALL TRUSSES. PROVIDE 1/2" EXTERIOR GRADE DRYWALL OR 1/2" EXTERIOR GRADE PLYWOOD WITH 8d NAILS AT 8" O.C. FIELD/4" O.C. EDGES.

13. ROOF PANEL NOTES

- 13.1 ROOF PANELS: 6" THICK COMPOSITE PANELS
- 13.2 TYPICAL PANEL SIZE: 4'xLENGTH REQ'D
- 13.3 TOP AND BOTTOM SKIN: 1/2" THICK OSB PANELS.
- 13.4 CORE MATERIAL: 7 1/2" THICK, 1.0 PCF EXPANDED POLYSTYRENE (EPS) FOAM
- 13.5 ADHESIVE: MOR-AD M650 SERIES BY ROHM AND HAAS
- 13.6 STRUCTURAL DESIGN OF PANELS IS FOR LOAD RESISTANCE ONLY. WATERPROOFING AND SEALING OF PANELS IS THE RESPONSIBILITY OF THE BUILDER.

REVISIONS
 DATE
 612 Paul Morris Drive
 Greenwood, FL 34223
 Phone: 941-475-8300 Cell: 941-915-3090
 www.newpanelhomes.com
NEW PANEL HOMES
JACK & DIANE BOYER
LITTLE GASPARILLA
PLACIDA, FL
 STRUCTURAL NOTES
 DATE: 2014-05-07

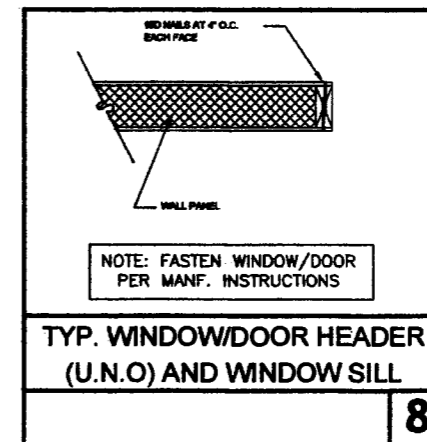
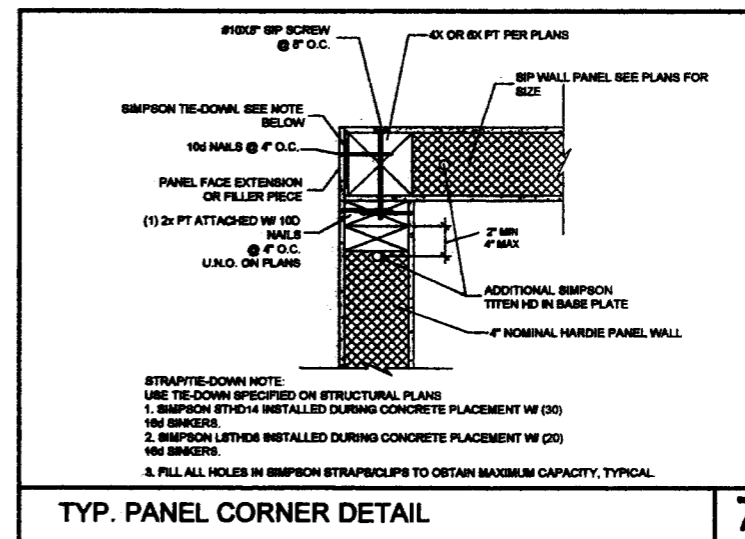
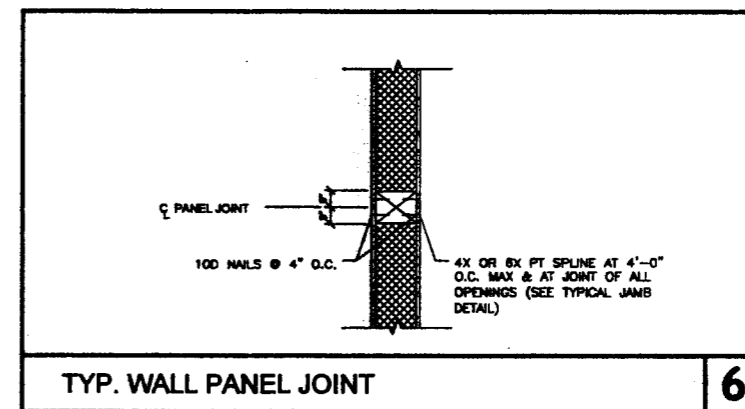
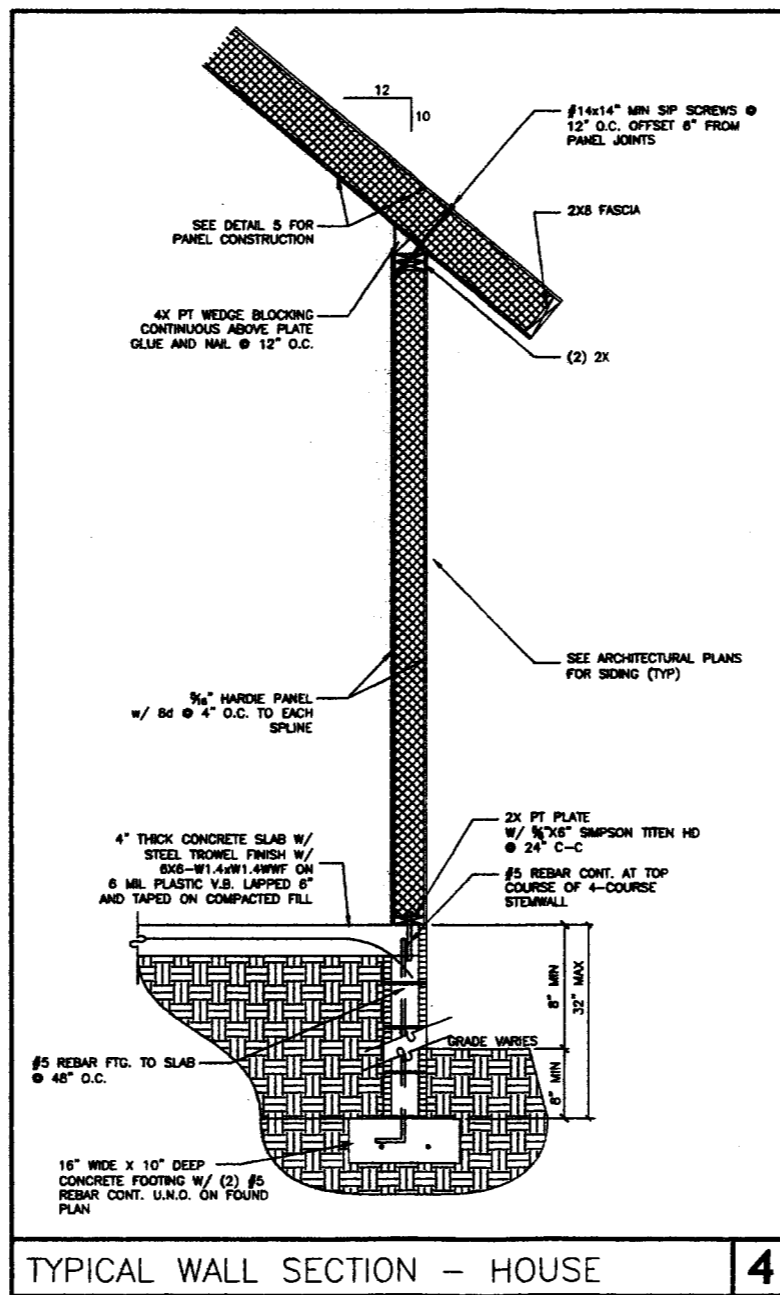
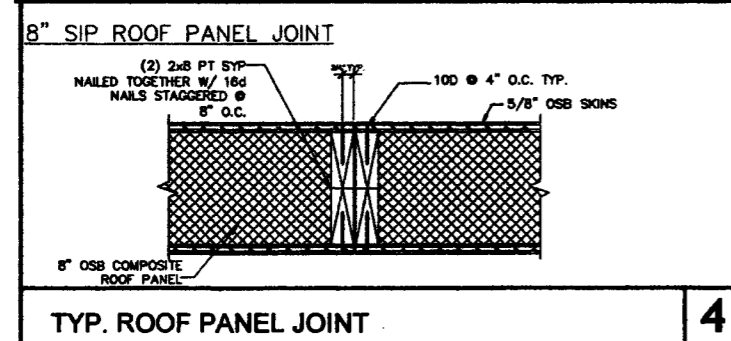
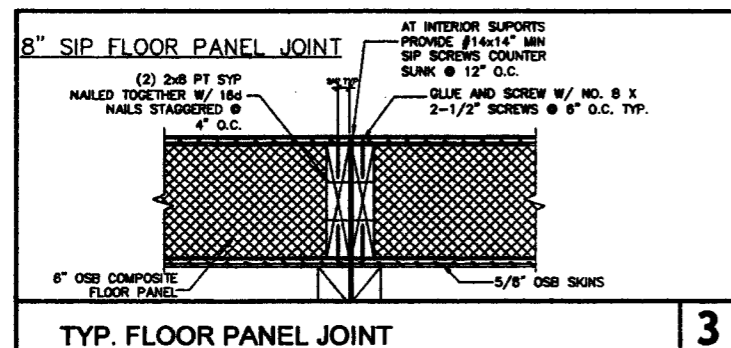
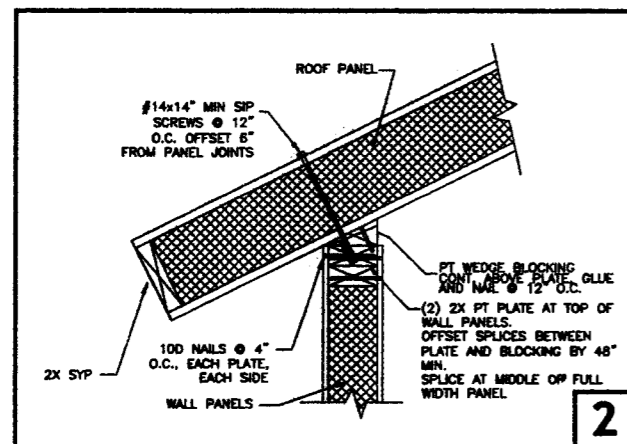
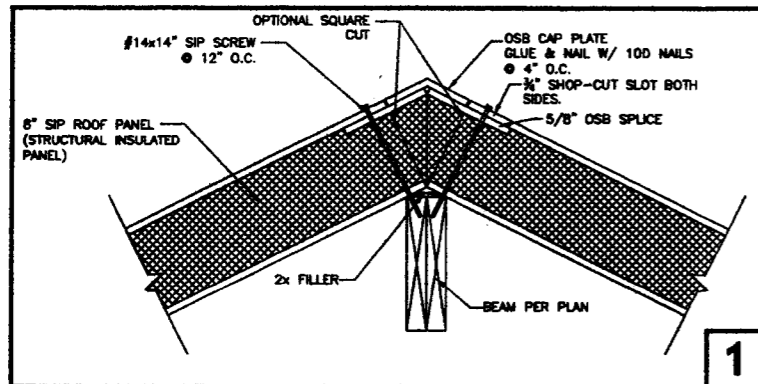

BRISTON W. FINELL, P.E. No. 5372
ENGINEER OF RECORD

C OF A 27860
1532 US HWY 41 BYP S #154
VENICE, FLORIDA 34293
941-451-8971
EMAIL: axisengr@gmail.com

Axis
AXIS ENGINEERING, PLC

512 Paul Morris Drive
Englewood, FL 34223
Phone: 941-475-8300 Cell 941-916-3090
www.newpanelhomes.com

NEW PANEL HOMES
JACK & DIANE BOYER
LITTLE GASPARILLA
PLACIDA, FL

REVISIONS
STRUCTURAL NOTES
S2
MILE DATE 2014-05-07

000568

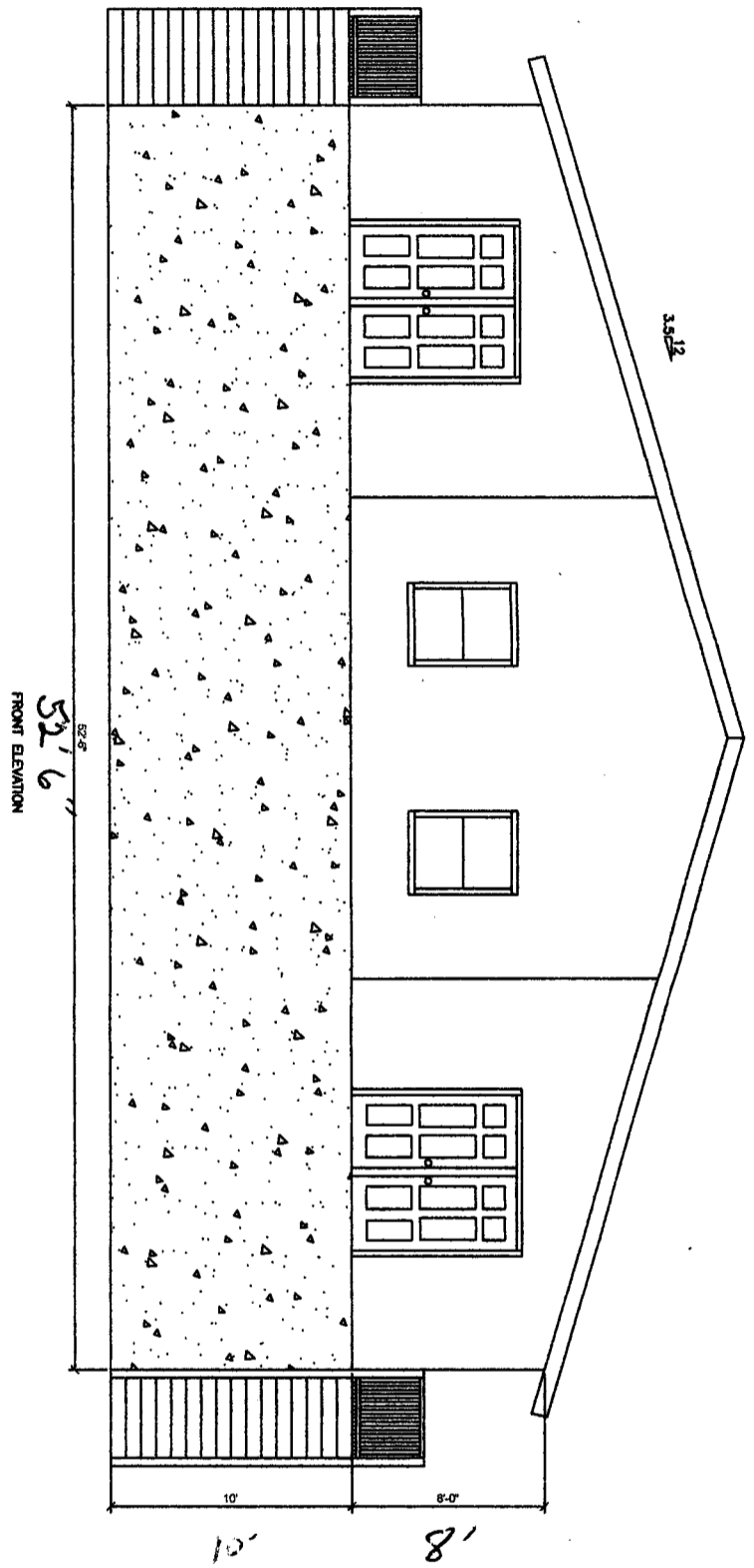
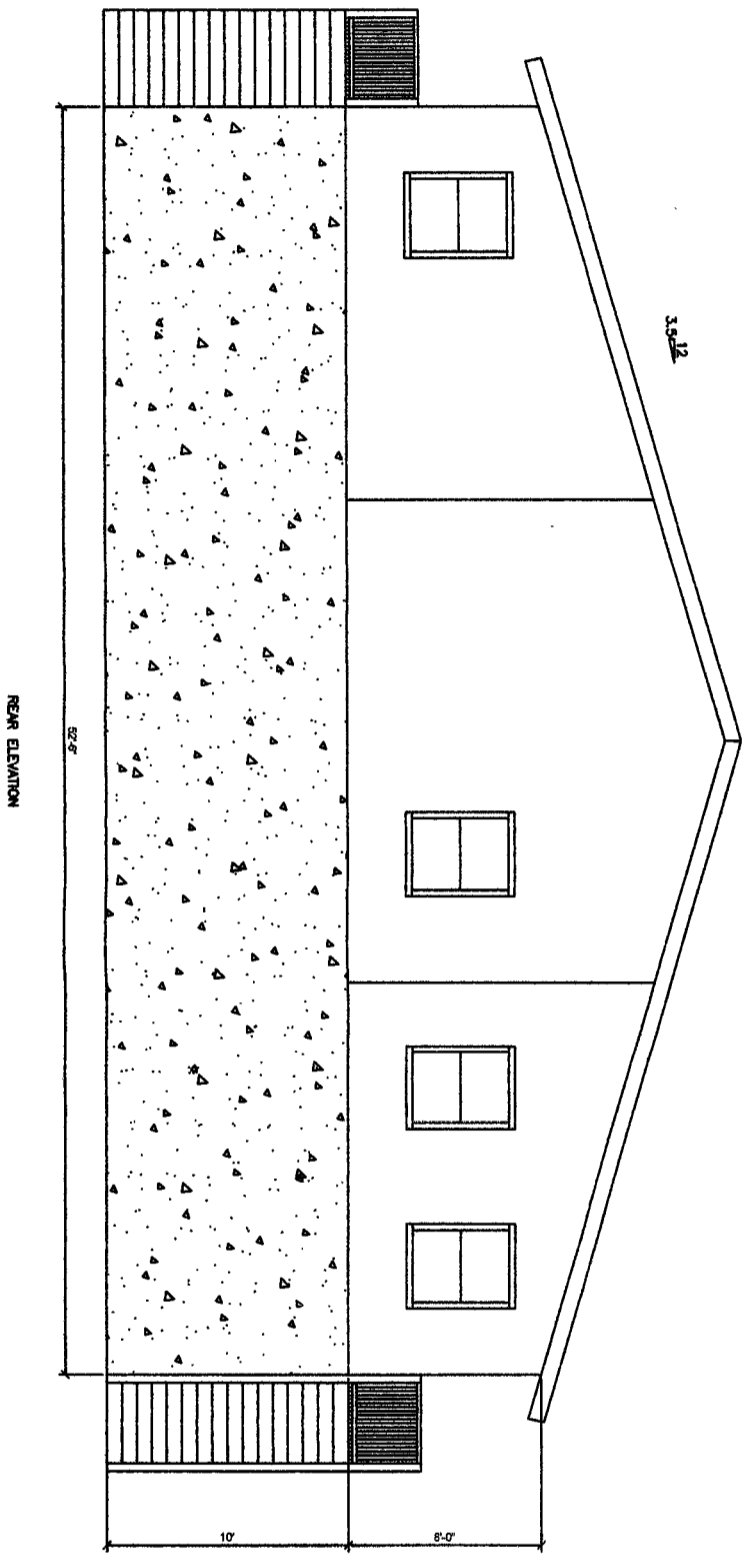

<p>SCALE: 1/8" = 1'-0"</p> <p>A 2.0</p> <p>DATE: 01/20/08</p>	<p>REVISIONS</p>	<p>JACK & DIANE BOYER LITTLE GASPARILLA PLACIDA, FL</p>	<p>NEW PANEL HOMES</p> <p>512 Paul Morris Drive Englewood, FL 34223 Phone: 941-475-8300 Cell 941-915-3090 www.newpanelhomes.com</p>	<p>AXIS AXIS ENGINEERING, PLC</p> <p>1532 US HWY 41 BYP S #154 VENICE FLORIDA 941-451-8971 34293 EMAIL: axisengr@gmail.com</p>	<p>C OF A 27860</p> <p>BENEFORD W. FORBELL, P.E. No. 63921 ENGINEER OF RECORD</p> <p>DATE:</p>
---	------------------	--	---	---	--

5159 Grove City 94824

25

EASEMENT FOR WATER UTILITIES

State of Florida, Charlotte County

PAGE 1

Glau Robert O & Joyce A, herein referred to as Grantor, in consideration of five (\$5,000) thousand dollars by Little Gasparilla Water Utilities, a public utility, privately owned, in the State of Florida, herein referred to as Grantee, has the intent of running an 8" water line to Little Gasparilla Island. Charlotte County Utilities and LGWU will need joint access to all metering devices but only LGWU on 8" water lines.

The receipt of which is hereby acknowledge, and other good and valuable consideration set out in the Utility Agreement entered between said parties on the 7th day of April, 2014

The provisions of said Agreement to be specifically incorporated herein by reference, have granted, bargained, sold and conveyed, and by these presents, do grant, bargain, sell and convey, to Grantee and to its successors and assigns, a non-exclusive perpetual utility easement and all rights-of-way for the purpose of constructing, laying, maintaining, and operating pipelines and all necessary laterals thereto to be used for water in addition to any ingress and egress necessary to enter and depart over and upon that portion of land to effect the purposes of the easement. The rights-of-way and easement will be fifteen feet (15') wide and the length 120 ft. along the Southerly boundary of lot 14.

SEE Exhibit "A" ATTACHED

It is intent of the Grantor by the provisions in the easement to convey to the Grantee a non-exclusive utility easement for as long as the Grantee requires the easement.

SKETCH AND DESCRIPTION:



REMAINDER OF LOT 14
 BLOCK S
 (CAPE HAZE SUBDIVISION)
 (PLAT BOOK 2, PAGE 93 THROUGH 93-B)
 (NOT INCLUDED)

R/W LINE

GREEN DOLPHIN DRIVE
 (50' R/W)

THE SOUTHERLY 15.0' OF LOT 14
 BLOCK S

LOT 1
 (CAPE HAZE SUBDIVISION OF BLOCK U)
 (PLAT BOOK 4, PAGE 46)

CURVE TABLE:

C-1
 Radius = 50.00'
 Arc = 15.23'
 Delta = 17°27'27"
 Chord Length = 15.18'
 Chord Bearing = S.00°27'21"E.

DRAFT

CONC. SEAWALL

N.09°11'05"W.
 15.00'

CONC. SEAWALL

PLACIDA HARBOR

LIMITS OF PLAT AND THE SOUTHERLY LOT LINE

N.80°48'55"E. 119.36'
 S.80°48'55"W. 117.05'

Handwritten notes:
 15.00'
 5.00'

NOTE:
 1. THIS IS NOT A BOUNDARY SURVEY
 2. THIS SKETCH AND DESCRIPTION CONTAINS TWO (2) SHEETS AND IS INTENDED TO BE USED IN ITS ENTIRETY.

SHEET 2 OF 2

DMK

DMK ASSOCIATES
 ENGINEERS/SURVEYORS
 4315 S. ACCESS ROAD
 ENGLEWOOD, FL. 34224
 TEL: (941) 475-6596
 FAX: (941) 475-1881

DATE: 03/14/14	JOB No. 13-0209
SCALE: 1"=20'	DWN. TOM CK'D WAM
UPDATES & REV.	DATE DWN. BY:

IN WITNESSOF, said Grantor has caused these presents to be signed in its name
this 7th day of April, 2014

WITNESS

Mary E. Glau

Robert O. Glau

Louise Rouleau

Robert O. Glau

Joyce A Glau

Joyce A. Glau

The foregoing instrument was acknowledge before me this 7th day of April, by
Robert O. Glau and are
Joyce A. Glau, who is personally known to me or has presented as
identification _____ and did/did not take an oath.

My commission expires:

Jennifer E. Nemes

Notary Public Signature

Jennifer E. Nemes

Printed Name of Notary

FF 091056

Serial or Commission Number

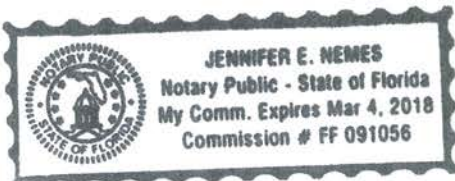

Easement for 'Water Utility

State of Florida

County of Charlotte

87,000 Cash Impact Fee \$145,000 = hook-up 13k total

Deborah L Green, herein referred to as Grantor, in consideration of 13,000 total by Little Gasparilla Water Utility Inc, a Public Utility, Regulated by Charlotte County and the Florida Public Commission, with a Certificated Area that includes Little Gasparilla Island, herein referred to as Grantee, the receipt of which is hereby acknowledged, and other good and valuable consideration set out in the Utility Agreement entered between said parties on the ____ day of _____, 2014, the provisions of said Agreement to be specifically incorporated herein by reference, have granted, bargained, sold, and conveyed, and by these presents, do grant, bargain, sell, and convey, to Grantee and to its successors and assigns, a non-exclusive perpetual utility easement and right-of-way for the purpose of constructing, laying, maintaining, and operating pipelines and all necessary laterals thereto to be used for water, (NOT wastewater), in addition to any ingress and egress necessary to enter or depart over and upon that portion of land to effect the purpose of the easement. The right-of-way and easement will be 8'(eight feet) wide, running East to West by 100' (one hundred feet) long, running North to South.

Attachment "A" Survey will be completed, with as-built drawings, upon completion of the installation of the 6" water main.

Easement for 'Water Utility

State of Florida

County of Charlotte

Puerto Jamie & Carolina M Sendon, herein referred to as Grantor, in consideration of 2 by Little Gasparilla Water Utility Inc, a Public Utility, Regulated by Charlotte County and the Florida Public Commission, with a Certificated Area that includes Little Gasparilla Island, herein referred to as Grantee, the receipt of which is hereby acknowledged, and other good and valuable consideration set out in the Utility Agreement entered between said parties on the ____ day of _____, 2014, the provisions of said Agreement to be specifically incorporated herein by reference, have granted, bargained, sold, and conveyed, and by these presents, do grant, bargain, sell, and convey, to Grantee and to its successors and assigns, a non-exclusive perpetual utility easement and right-of-way for the purpose of constructing, laying, maintaining, and operating pipelines and all necessary laterals thereto to be used for water, (NOT wastewater), in addition to any ingress and egress necessary to enter or depart over and upon that portion of land to effect the purpose of the easement. The right-of-way and easement will be 8' (eight feet) wide, running East to West by 50' (fifty feet) long, running North to South.

Attachment "A" Survey will be completed, with as-built drawings, upon completion of the installation of the 6" water main.

Home Mail News Sports Finance Weather Games Groups Answers Screen Flickr Mobile More

Search Mail Search Web Jack

Compose Delete Move Spam More Sponsored

- Inbox
- Drafts (1)
- Sent
- Spam (567)
- Trash (9)
- ▼ Folders (17)
 - Accounting
 - appraisals
 - ATT
 - Boat
 - Britt
 - credit
 - Deleted Items (16)
 - e-bay
 - Erin's wedding
 - Farmers Market
 - forms
 - FPL-LGWU
 - HC LLC.
 - Holy Land 2012
 - Insurance
 - Investors
 - Islands
 - KIU
 - Legal
 - LGWU
 - loans
 - Marinas
 - N.C. Property
 - Notes
 - OFF-THE-HOOK
 - O-T-H
 - PAT
 - Pedals Pushers
 - Pictures
 - PSC
 - Rocky Creek
 - Sent Items
 - Synced Messages
 - Taxes (1)
 - Testimonys
 - Wallace
 - YL

Re: LGI easement

DDTatum1212@aol.com May 13 at 11:11 PM

To lwjd777@yahoo.com

Jack,

Bill and I are OK with the easement of 5 feet on the west side of the property line. I'm sure that you will need some signatures and if it would be convenient we plan to be on the island over Memorial Day weekend. Give us a call if you can meet during that time.

We haven't listed the house yet but think somewhere in the area of \$275K. We will be asking the realtor to do some price comparisons for comparable homes on the island.

Diane
813-546-8297

In a message dated 5/9/2014 1:55:49 P.M. Eastern Daylight Time, lwjd777@yahoo.com writes:

Hi Diane and nice to here from you! I would like to run the water line on the west property line. A five foot easement will be plenty and yes we will transfer any credit at anytime you would like. If you don't mind me asking, what is the price on your home?
Thanks and have a Blessed Day!
jack

From: "ddatum1212@aol.com" <ddatum1212@aol.com>
To: lwjd777@yahoo.com; lgwu777@yahoo.com
Sent: Friday, May 9, 2014 12:30 PM
Subject: LGI easement

Good morning,

Sorry to take so long to get back to you but I needed to s/w my husband to refresh my memory about our conversation. We both remembered that there would be a \$1000 credit for our water but the question was where on the property the water line would come through. If possible could you email me something that shows what the are in question is? I know that we have spoken about this at least on 2-3 occasions and I believe that the plan changed after the first time we talked. We want to make sure we know where it will be. Also we would like to be able to put our house up for sale in the near future and want to make sure that the remaining water credit will either be paid out to us if we sell the house or will be transferred to the new owner.

Thank you

Diane Tatum
ddatum1212@aol.com

70% Off Danner Boots for Men
The Clymb

Overstock Clearance - 7" Tablet PC for only \$59!
Nomorerack.com

\$0 Down Home Loan for Veterans- See if You Qualify
Veterans United

Upgrade Your Home with Quality Laminate Flooring
BuildDirect®

How old is your body?
RealAge



Instaflex
Joint Relief for Ages 55+

by MADDIE PHOTOGRAFY on Flickr



Pipe
Backhoe
Labor

Please make Note

Lead-Free Curb Stops Regular Pattern Ball Valves

psi water

valves are all available with a Minneapolis thread pattern at extra cost; contact USABlueBook for more details.



	PORT SIZE	OUTLET	MFR #	STOCK #	EACH
COPPER TUBING					
Female Iron Pipe	3/8"	3/4" Female Iron Pipe	76101	21072	\$ 50.95
Female Iron Pipe	3/4"	3/4" Female Iron Pipe	76101	21073	80.95
Female Iron Pipe	1"	1" Female Iron Pipe	76101	21074	122.95
Tube Compression	3/8"	3/4" Tube Compression	76100T	21075	63.95
Tube Compression	3/4"	3/4" Tube Compression	76100T	21076	102.95
Tube Compression	1"	1" Tube Compression	76100T	21077	154.95
Mac-Pak Tube Compression	3/4"	3/4" Mac-Pak Tube Compression	76100-22	21078	102.95
Mac-Pak Tube Compression	1"	1" Mac-Pak Tube Compression	76100-22	21079	154.95
Mac-Pak Tube Compression	3/8"	3/4" Female Iron Pipe	76102-22	21080	59.95
Mac-Pak Tube Compression	3/4"	3/4" Female Iron Pipe	76102-22	21081	89.95
Mac-Pak Tube Compression	1"	1" Female Iron Pipe	76102-22	21082	138.95
SCH 40 PE PIPE					
Mac-Pak TC Poly Pipe (Sch 40)	3/4"	3/4" Female Iron Pipe	76102-33	21083	\$ 107.95
Mac-Pak TC Poly Pipe (Sch 40)	1"	1" Female Iron Pipe	76102-33	21084	151.95
Mac-Pak TC Poly Pipe (Sch 40)	3/4"	3/4" Mac-Pak TC Poly Pipe (Sch 40)	76102-33	21085	131.95
Mac-Pak TC Poly Pipe (Sch 40)	1"	1" Mac-Pak TC Poly Pipe (Sch 40)	76102-33	21086	199.95
SCH 40 PVC PIPE					
Mac-Pak TC PVC Pipe	3/4"	3/4" Female Iron Pipe	76102-44	21087	\$ 107.95
Mac-Pak TC PVC Pipe	1"	1" Female Iron Pipe	76102-44	21088	151.95
Mac-Pak TC PVC Pipe	3/4"	3/4" Mac-Pak TC PVC Pipe	76102-44	21089	132.95
Mac-Pak TC PVC Pipe	1"	1" Mac-Pak TC PVC Pipe	76102-44	21090	199.95
McQuick Tighten to Stop Compression	3/8"	3/4" McQuick Tighten to Stop Compression	76100Q	21091	63.95
McQuick Tighten to Stop Compression	3/4"	3/4" McQuick Tighten to Stop Compression	76100Q	21092	102.95
McQuick Tighten to Stop Compression	1"	1" McQuick Tighten to Stop Compression	76100Q	21093	154.95

We sell insert stiffeners which are recommended on all compression type flexible plastic connections. See below.



21075



21091



21078

Lead-Free Straight Meter Valves

all style, 300 psi with lock wing

SIZE	METER SIZE	INLET TYPE	PIPE SIZE/TYPE	MFR #	STOCK #	EACH
3/4"	3/8" or 1/2" x 3/4"	Copper Flare	3/4" CT	76100MW	21062	\$ 102.95
1"	3/8" or 1/2" x 3/4"	Copper Flare	1" CT	76100MW	21063	153.95
3/4"	3/8" or 1/2" x 3/4"	Mac-Pak Tube Compression	3/4" CT	76100MW-22	21064	108.95
1"	3/8" or 1/2" x 3/4"	Mac-Pak Tube Compression	1" CT	76100MW-22	21065	156.95
3/4"	3/8" or 1/2" x 3/4"	Mac-Pak TC Poly Pipe (Sch 40)	3/4" PE	76100MW-33	21066	115.95
3/4"	3/8" or 1/2" x 3/4"	Mac-Pak TC PVC Pipe	3/4" PVC	76100MW-44	21067	115.95
3/4"	3/8" or 1/2" x 3/4"	Female Iron Pipe	3/4" FIP	76101MW	21068	95.95
1"	3/8" or 1/2" x 3/4"	Female Iron Pipe	1" FIP	76101MW	21069	142.95
3/4"	3/8" or 1/2" x 3/4"	McQuick Tighten to Stop Compression	3/4" CT	76100MWQ	21070	108.95
1"	3/8" or 1/2" x 3/4"	McQuick Tighten to Stop Compression	1" CT	76100MWQ	21071	156.95

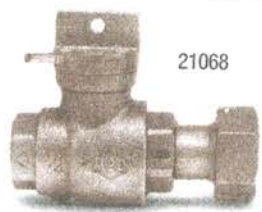

21068



21070



21062



21064

Lead-Free Meter Idlers

temporary meter bypass when meter is out for service

Idlers let you maintain proper spacing until service is ready for a meter. Sizes are available—call USABlueBook for more information.

MFR #	STOCK #	EACH
740MJ07-5/8 x 3/4	48246	\$ 28.95
740MJ09-3/4	48248	37.95

Insert Stiffeners (McDonald Series 6133T & 6136)



Recommended on all flexible plastic connections. Stainless steel.

SIZE	FOR POLYETHYLENE TUBING		FOR POLYETHYLENE PIPE (IPS)	
	STOCK #	EACH	STOCK #	EACH
3/4"	48780	\$ 2.09	48784	\$ 2.39
1"	48782	2.19	48786	2.69

See page 1055 for Teflon® tape.

Plastic Meter and Valve Boxes

reinforced design
 sturdy lid design on 1200 series
 reinforced plastic for long life

Corrosion-proof plastic meter and valve boxes are specially designed for extra strength and long service life. The 1200 series 12" high rectangular boxes feature a unique double ledge lid support that combines the features of a drop-in lid with the strength of an overlapping lid. We've also added 6" extensions to fit the 1200 series—great for deeper pipelines or those last minute grade changes. Special lids to accommodate touch screens and AMR transmitters are available.

**Most in stock
 to ship today**



**Call for
 net pricing**

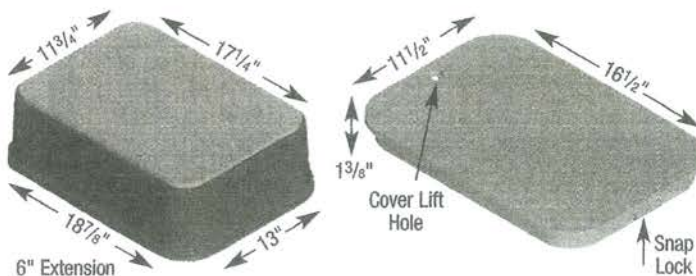
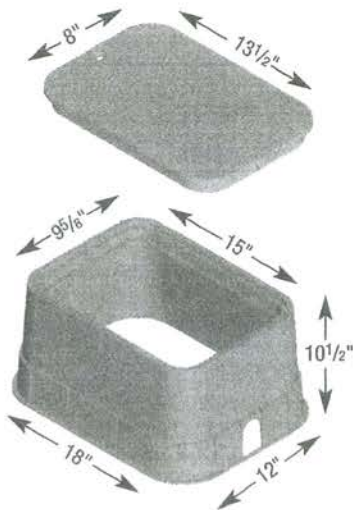

Series 1200 12" Rectangular Meter Boxes & 6" Extension

Covers available with plastic or cast iron reader. Special lids with read pad hole or AMR transmitter bracket are available. Black. Seventy-two per pallet.

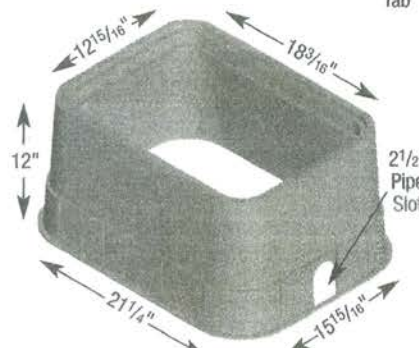

Series 1000 Rectangular Meter Boxes

meter box
 with plastic
 black. Ninety-six

DESCRIPTION	STOCK #	EACH	QTY 10+
Box Only	62040	\$ 17.49	\$ 16.62
Plastic Lid	62042	\$ 11.49	\$ 10.92
Cast Iron Reader	62041	11.49	10.92

DESCRIPTION	STOCK #	EACH	QTY 10+
SERIES D-1200			
Box Only	62045	\$ 17.49	\$ 16.62
6" Extension	62046	14.99	14.24
SERIES 1200 LIDS			
Standard Solid Lid	62047	\$ 10.99	\$ 10.44
Lid w/ Plastic Reader Door	62048	10.99	10.44
Lid w/ Cast Iron Reader Door	62049	12.99	12.34
Lid w/ Read Pad Hole	62050	13.99	13.29
Lid w/ AMR Bracket	62051	18.99	18.04

*25.00
 Each*

Series 1100 Round Valve Boxes

ring cover
 dirt and grass
 ring between
 cover. Available
 down lid. Green.
 line per pallet.

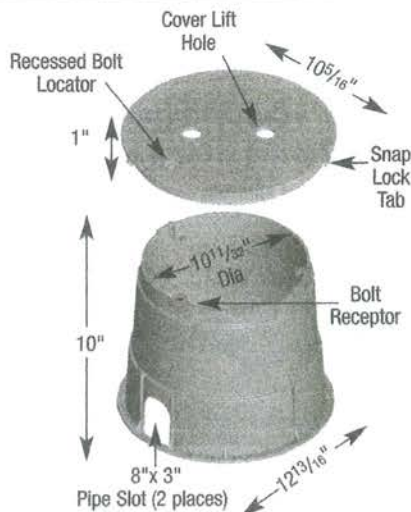

Series 109 6" Economy Valve Boxes

Snap-in overlapping cover prevents dirt and grass from getting between body and cover. Lower body green only. Can be nested for shipping. Extend valve box with any 6" plastic or iron pipe. Thirty-six per carton.

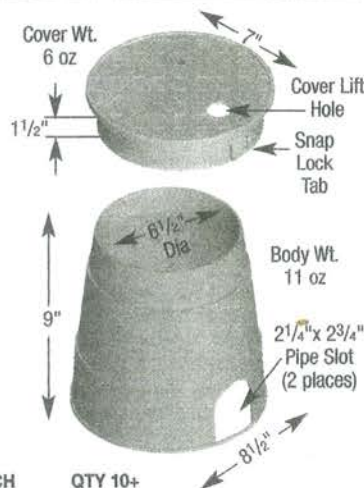

DESCRIPTION	STOCK #	EACH	QTY 10+
Box Only	62033	\$ 7.19	\$ 6.83
Box Only, Allows Lid to be Bolted Down	62032	7.59	7.21
Drop-In Lid	62034	\$ 5.69	\$ 5.41

DESCRIPTION	STOCK #	EACH	QTY 10+
SERIES D-109			
Box Only, D-109	62030	\$ 3.89	\$ 3.81
SERIES 109 LIDS			
Drop-In Lid	62031	\$ 2.29	\$ 2.24

3401 Pipe Saddles

Pipe Class
1 & 26
install



ed seal.
the main
seal

LET SIZE*	STOCK #	EACH
C	24200	\$ 35.95
PT	24202	35.95
C	24204	34.95
PT	24206	34.95
C	24208	37.95
PT	24210	37.95
C	24212	43.95
PT	24214	43.95
C	24216	43.95
PT	24218	43.95
C	24220	42.95
PT	24222	42.95
C	24224	42.95
PT	24226	42.95
C	24228	51.95
PT	24230	51.95
C	24232	51.95
PT	24234	51.95
C	24236	71.95
PT	24238	71.95
C	24240	71.95
PT	24242	71.95

A thread.



PIPE TOOLS & VISES
SINCE 1896

tooth Jaw Wrenches

in't damage corp stops
up to 2"

ooth jaw wrench to install corp stops up to 2" without
ss like normal pipe wrenches can. Its 4-5/8" opening
gh to open and close valves. Weighs only 4.4 lbs.

rench	STOCK #	EACH
	25114	\$ 71.95



Smith-Blair® Series 317 Pipe Saddles

- Flexi-Blue™ epoxy-coated ductile iron body with double stainless steel straps and NSF Buna-N gasket



Saddles cover pipe diameters commonly used in water systems. Saddles with pipe OD ranges from 1-1/2" through 24" pipe are available as special order. Contact USABlueBook for more information.

PIPE SIZE/TYPE	PIPE OD RANGE	TAP*	STOCK #	EACH	QTY 10+
3" Sch 40 IPS CTS	2.97 to 3.54"	3/4" CC	24317	\$ 76.95	CALL
		3/4" NPT	24318	76.95	CALL
		1" CC	24319	76.95	CALL
		1" NPT	24321	76.95	CALL
		1 1/2" CC	24253	84.95	CALL
		1 1/2" NPT	24255	84.95	CALL
		2" NPT	24251	84.95	CALL
		3/4" CC	24323	76.95	CALL
		3/4" NPT	24325	76.95	CALL
		1" CC	24327	76.95	CALL
3" DI CTS (4")	3.74 to 4.13"	1" NPT	24329	76.95	CALL
		1 1/2" CC	24281	81.95	CALL
		1 1/2" NPT	24283	81.95	CALL
		2" CC	24285	87.95	CALL
		2" NPT	24287	87.95	CALL
		3/4" CC	24331	76.95	CALL
		3/4" NPT	24333	76.95	CALL
		1" CC	24335	76.95	CALL
		1" NPT	24337	76.95	CALL
		1 1/2" CC	24289	81.95	CALL
4" Sch 40 IPS	4.40 to 4.50"	1 1/2" NPT	24291	81.95	CALL
		2" CC	24293	87.95	CALL
		2" NPT	24295	87.95	CALL
		3/4" CC	24339	76.95	CALL
		3/4" NPT	24341	76.95	CALL
		1" CC	24342	76.95	CALL
		1" NPT	24343	76.95	CALL
		1 1/2" CC	24297	81.95	CALL
		1 1/2" NPT	24299	81.95	CALL
		2" CC	24301	89.95	CALL
4" C900 DI	4.40 to 4.80"	2" NPT	24303	89.95	CALL
		3/4" CC	24344	88.95	CALL
		3/4" NPT	24345	88.95	CALL
		1" CC	24346	88.95	CALL
		1" NPT	24347	88.95	CALL
		1 1/2" CC	24305	92.95	CALL
		1 1/2" NPT	24307	92.95	CALL
		2" CC	24309	100.95	CALL
		2" NPT	24311	100.95	CALL
		3/4" CC	24348	99.95	CALL
6" C900 DI Sch 40 IPS	5.94 to 6.90"	3/4" NPT	24349	99.95	CALL
		1" CC	24350	99.95	CALL
		1" NPT	24351	99.95	CALL
		1 1/2" CC	24312	105.95	CALL
		1 1/2" NPT	24313	105.95	CALL
		2" CC	24314	114.95	CALL
		2" NPT	24316	114.95	CALL
		3/4" CC	24352	121.95	CALL
		3/4" NPT	24353	121.95	CALL
		1" CC	24354	121.95	CALL
8" C900 DI Sch 40 IPS	7.69 to 9.05"	1" NPT	24355	121.95	CALL
		1 1/2" CC	24356	128.95	CALL
		1 1/2" NPT	24357	128.95	CALL
		2" CC	24358	139.95	CALL
		2" NPT	24359	139.95	CALL

* CC outlet is AWWA thread.



PIT-MOUNT METERS				WALL-MOUNT METERS	
SIZE	END	STOCK #	EACH	STOCK #	EACH
TOUCH-READ GALLONS					
3/4" x 1/2"	Thread	17161	\$ 126.95	17444	\$ 147.95
3/4" x 3/4"	Thread	17163	126.95	17445	147.95
3/4" Short	Thread	17371	165.95	17446	187.95
1/2" x 1/2"	Thread	18182	210.95	18184	232.95
1"	Thread	17377	240.95	17447	263.95
1 1/2"	Flange	18196	439.95	24044	459.95
2"	Flange	18197	604.95	24045	629.95
TOUCH-READ CUBIC FEET					
3/4" x 1/2"	Thread	17383	\$ 126.95	17448	\$ 147.95
3/4" x 3/4"	Thread	17441	126.95	17449	147.95
3/4" Short	Thread	17442	165.95	17502	187.95
1/2" x 3/4"	Thread	18183	210.95	18185	232.95
1"	Thread	17443	240.95	17509	263.95
1 1/2"	Flange	18198	439.95	24046	459.95
2"	Flange	18199	604.95	24047	629.95

Readers & Installation Accessories

DESCRIPTION	STOCK #	EACH
Handheld Reader, Pit Pad with 36" Wand	10129	\$ 2,496.00
Handheld Reader, Wall Pad	10128	1,995.00
Installation Coupling, 3/8" x 1/2"	73191	13.49
Installation Coupling, 3/4" & 5/8" x 3/4"	73192	14.99
Installation Coupling, 1"	73193	23.95
Flange Kit, No-Lead Bronze, 1 1/2"	73196	144.95
Flange Kit, No-Lead Bronze, 2"	73197	195.95
22-GA Meter Wire, 500' Roll"	50452	99.95



Thread. Nut is drilled for wire
p. Brass couplings include:
gasket: EPDM gasket and
added reinforcement.

each meter to be
individually; PVC



METER SIZE	TAILPIECE	THREAD	STOCK #	EACH	QTY 12+
NO-LEAD BRASS (SOLD INDIVIDUALLY)					
3/8" x 1/2"	1/2"	NPT	73191	\$ 13.49	\$ 12.82
3/4", 5/8" x 3/4"	3/4"	NPT	73192	14.99	14.24
1"	1"	NPT	73193	23.95	22.75
1 1/2"	1 1/2"	NPT	73194	54.95	52.20
2"	2"	NPT	73195	79.95	75.95
PVC (SOLD IN PAIRS)					
3/4", 5/8" x 3/4"	3/4"	NPT	73137	\$ 29.95	\$ 28.45
1"	1"	NPT	73138	47.95	45.55



Introducing Lead-Free Zenner® Water Meters

USABlueBook is pleased to announce our new partnership with Zenner. Each year, Zenner produces more than three million water meters worldwide. With more than 100 years of experience, Zenner water meters are manufactured with superior quality and built for longevity.



Zenner® Lead-Free Positive Displacement Water Meters

- Highly accurate measuring chamber design
- Complies with AWWA C-700 and NSF/ANSI 61-G Lead-Free standards
- Choose from direct read or remote read (includes battery-powered remote digital display)

Ensure your water system has the highest possible revenue and lowest possible maintenance costs with these accurate, dependable water meters. The oscillating piston measuring chamber design has a proven track record of durability and accuracy. The magnetically driven, hermetically sealed design eliminates dirt and moisture infiltration, and prevents fogging. The register includes a large odometer-type totalization display, center sweep hand (360°) test circle and low flow leak detection.

Choose from stock meters in sizes 5/8" x 1/2" to 2" in direct read or remote read styles. Remote read meters feature a battery-powered wall-mount remote reader with digital display. Meters up to 1" have a plastic lid and register housing with brass bottom plate. Meters in 1-1/2" and 2" sizes come with brass lids and register housings. The main case is constructed using C89833 brass alloy, which meets NSF-61 low-lead requirements.

Note: Remote read units include 5 feet of connecting wire; longer cable sold separately.

Accuracy:	98.5 to 101.5%
Max operating pressure:	150 psi
Max operating temp:	122°F
Materials	
Main case:	C89833 brass alloy
Bottom plate:	bronze
Measuring chamber:	polystyrene and POM
Register can:	polycarbonate or brass
Register lens:	tempered glass
Max wire length (remote read):	500 feet
Meter output (remote read):	ETR encoder output, ASCII format
Wall-mount reader dimensions:	4.6"W x 4.3"H x 2"D

NEW!



1 1/2" Direct Read Model



Remote read models include battery-powered wall-mount remote reader



SIZE	Meters Reading in Gallons		Meters Reading in Cubic Feet		DIRECT READ STOCK #	EACH	DIRECT READ STOCK #	EACH	REMOTE READ STOCK #	EACH
	DIRECT READ STOCK #	REMOTE READ STOCK #	DIRECT READ STOCK #	REMOTE READ STOCK #						
5/8" x 1/2"	16571	\$ 62.95	16577	\$ 214.95	16634	\$ 62.95	18171	\$ 214.95		
5/8" x 3/4"	16572	62.95	16578	214.95	16635	62.95	18172	214.95		
3/4" Short	16573	89.95	16579	256.95	16636	89.95	18173	256.95		
3/4" x 3/4"	18177	132.95	18179	304.95	18178	132.95	18181	304.95		
1"	16574	160.95	16631	334.95	16637	160.95	18174	334.95		
1 1/2"	16575	404.95	16632	529.95	16638	404.95	18175	529.95		
2"	16576	549.95	16633	699.95	16639	549.95	18176	699.95		

Installation Accessories & Replacement Parts

DESCRIPTION	STOCK #	EACH
Installation Coupling, 5/8" x 1/2"	73191	\$ 13.49
Installation Coupling, 3/4" and 5/8" x 3/4"	73192	14.99
Installation Coupling, 1"	73193	23.95
Flange Kit, No-Lead Bronze 1 1/2"	73196	144.95
Flange Kit, No-Lead Bronze 2"	73197	195.95
22-GA Meter Wire, 500' Roll	50452	99.95

REPLACEMENT PARTS

Measuring Chamber for 5/8" x 1/2" and 5/8" x 3/4" Meters	17057	\$ 19.99
Freeze Plate for 5/8" x 1/2" and 5/8" x 3/4" Meters	17083	17.99

Flow Ranges for Zenner PPD Series Water Meter

Size	Flow Range (gpm)		Connection
	Min-Max	Max Continuous	
5/8" x 1/2"	1/8 to 20	15	1/2" Male Union
5/8" x 3/4"	1/8 to 20	15	3/4" Male Union
3/4" Short	1/4 to 30	20	3/4" Male Union
3/4" x 3/4"	1/4 to 30	20	3/4" Male Union
1"	1/4 to 50	25	1" Male Union
1 1/2"	1 1/2" to 100	50	2-Bolt Oval Flange
2"	2 to 160	80	2-Bolt Oval Flange

QUANTITY pricing!

For 1" and smaller meters:

- Buy 12-35 meters, save 5%
- Buy 36-59 meters, save 10%
- Buy 60+ meters, call for pricing

For all 1 1/2" and 2" meters:

- Buy 5-14 meters, save 5%
- Buy 15-24 meters, save 10%
- Buy 25+ meters, call for pricing

Meters must be same model

FLOW METERING Meter Brass

A.Y. McDonald Lead-Free Meter Brass

• These lead-free models meet ANSI/AWWA C800-05 and conform with California Prop 65

A.Y. McDonald Mfg. Co. has been a leading manufacturer of Waterworks Brass since 1856. They have distinguished themselves with a proud tradition of quality and reliability. They offer a huge assortment of meter brass.



21037



21047



73077



73083



21045



21049



73079



73085

Lead-Free Corporation Stops

• Designed for low-turning torques and high pressures (300 psi)

These corporation stops feature ball valves with AWWA standard (tapered/cc) thread. Ball valves still operate smoothly after being in the ground for years, vs plug valves which eventually lock up in one position.

OUTLET TYPE	SIZE	MFR #	STOCK #	EACH
3/4" AWWA x McQuick CTS	3/4"	74701BQ-3/4	21037	\$ 74.95
1" AWWA x McQuick CTS	1"	74701BQ-1	21038	99.95
1 1/2" AWWA x McQuick CTS	1 1/2"	74701BQ-11/2	21039	219.95
2" AWWA x McQuick CTS	2"	74701BQ-2	21040	329.95
3/4" NPT x McQuick CTS	3/4"	74704BQ-3/4	21041	75.95
1" NPT x McQuick CTS	1"	74704BQ-1	21042	99.95
1 1/2" NPT x McQuick CTS	1 1/2"	74704BQ-11/2	21043	219.95
2" NPT x McQuick CTS	2"	74704BQ-2	21044	369.95
3/4" AWWA x Copper Flare	3/4"	74701B-3/4	21045	73.95
1" AWWA x Copper Flare	1"	74701B-1	21046	92.95
3/4" AWWA x Tube Compression	3/4"	74701BT-3/4	21047	75.95
1" AWWA x Tube Compression	1"	74701BT-1	21048	99.95
3/4" AWWA x Mac-Pak Tube Compression	3/4"	74701B-22	21049	75.95
1" AWWA x Mac-Pak Tube Compression	1"	74701B-22	21050	99.95

FOR SCH 40 PE PIPE				
3/4" AWWA x Mac-Pak TC Poly Pipe (Sch 40)	3/4"	74701B-33	21051	\$ 91.95
1" AWWA x Mac-Pak TC Poly Pipe (Sch 40)	1"	74701B-33	21052	112.95
FOR SCH 40 PVC PIPE				
3/4" AWWA x Mac-Pak TC PVC Pipe	3/4"	74701B-44	21053	\$ 91.95
1" AWWA x Mac-Pak TC PVC Pipe	1"	74701B-44	21054	112.95

Note: We sell insert stiffeners which are recommended on all compression type flexible plastic connections. See page 357.

Lead-Free Angle Meter Valves

• Ball style, 300 psi with lock wing

Rubber washers are included. All meter valves come with lock wings.



21055



21058

VALVE SIZE	INLET TYPE	METER SIZE	SIZE	MFR #	STOCK #	EACH
3/4"	Copper Flare	3/4" or 5/8" x 3/4"	3/4"	74642B	21055	\$ 75.95
3/4"	Tube Compression	3/4" or 5/8" x 3/4"	3/4"	74642BT	21056	89.95
1"	Tube Compression	1"	1"	74642BT	21057	139.95
3/4"	Mac-Pak Tubing Compression	3/4" or 5/8" x 3/4"	3/4"	74642B-22	21058	69.95
1"	Mac-Pak Tubing Compression	1"	1"	74642B-22	21059	139.95
3/4"	Female Iron Pipe	3/4" or 5/8" x 3/4"	3/4"	74644B	21060	66.95
1"	Female Iron Pipe	1"	1"	74644B	21061	117.95

Lead-Free Straight Couplings

TYPE	INLET TYPE	OUTLET TYPE	MFR #	STOCK #
Copper Flare	3/4"	3/4" MIP	74753	73077
Copper Flare	1"	1" MIP	74753	73078
Tube Compression	3/4"	3/4" MIP	74753T	73079
Tube Compression	1"	1" MIP	74753T	73080
Mac-Pak Tube Compression	3/4"	3/4" MIP	74753-22	73081
Mac-Pak Tube Compression	1"	1" MIP	74753-22	73082
Copper Flare	3/4"	3/4" FIP	74754	73083
Copper Flare	1"	1" FIP	74754	73084
Tube Compression	3/4"	3/4" FIP	74754T	73085
Tube Compression	1"	1" FIP	74754T	73086
McQuick Compression	3/4"	3/4" MIP	74753Q	73087
McQuick Compression	1"	1" MIP	74753Q	73088

50-State Lead-Free Regulations for Drinking Water

Lead can cause serious health problems if too much enters your body from drinking water or other sources. It damages the brain and kidneys, and can interfere with the production of red blood cells that carry oxygen to all parts of your body. The greatest risk of lead exposure is to infants, young children and pregnant women.

As of January 4, 2014, all manufacturers, sellers, installers, plumbers and municipalities in all 50 U.S. states must comply with the Reduction of Lead in Drinking Water Act. Lead-free is defined as containing 0.25% or less of lead by weight.

How this affects you:

If your installation has the potential for potable water use, you must now and install lead-free items. You can no longer buy and install traditional waterworks bronze and brass materials. Risks to you include lawsuits from concerned citizens and governments and regulatory violations (3rd party and federal institutions). This can result in fines and possible permit revocation.

USABlueBook can help you meet these regulations. We stock hundreds of lead-free water service fittings, meters, valves and other affected items. We offer products that comply for all types of water installations. Please feel free to contact us with any questions that you have about this new Act.

