

**BELLSOUTH**

**ORIGINAL**

**BellSouth Telecommunications, Inc.**  
**Regulatory & External Affairs**

150 South Monroe Street  
400  
Tallahassee, FL 32301-1556

marshall.criser@bellsouth.com

**Marshall M. Criser III**  
Vice President  
Regulatory & External Affairs

850 224 7798  
Fax 850 224 5073

RECEIVED-PPSC  
OCT 20 PM 4:24  
COMMISSION  
CLERK

October 20, 2004

Mrs. Blanca S. Bayo  
Director, Division of The Commission Clerk and Administrative Services  
Florida Public Service Commission  
2540 Shumard Oak Boulevard  
Tallahassee, Florida 32399

RE: Docket 040648-TP Approval of the IURC agreement negotiated by BellSouth Telecommunications, Inc. and Local Line America, Inc.

Dear Ms. Bayo:

BellSouth re-files pages 151-308 of the above agreement in the above docket. It has been filed twice previously, but the pages have been illegible.

Please accept the attached page(s) as correction of the initial filing and existing docket file.

I would appreciate your assistance in correcting the filing and record in question.

Very truly yours,

- CMP \_\_\_\_\_
- COM \_\_\_\_\_
- CTR \_\_\_\_\_
- ECR \_\_\_\_\_
- GCL \_\_\_\_\_
- OPC \_\_\_\_\_
- MMS \_\_\_\_\_
- RCA \_\_\_\_\_
- SCR \_\_\_\_\_
- SEC   1
- OTH \_\_\_\_\_

*MM Criser III / RN*  
Regulatory Vice President

RECEIVED & FILED

*Jh*  
FPSC-BUREAU OF RECORDS

DOCUMENT NUMBER-DATE

11322 OCT 20 04

FPSC-COMMISSION CLERK

UNBUNDLED NETWORK ELEMENTS - Florida

CATEGORY	RATE ELEMENTS	Interim	Zone	BCS	USOC	RATES (\$)	Svc Order Submitted Elec per LSR	Svc Order Submitted Manually per LSR	Attachment: 2		Exhibit: A	
									Incremental Charge - Manual Svc Order vs. Electronic-1st	Incremental Charge - Manual Svc Order vs. Electronic-Add'l	Incremental Charge - Manual Svc Order vs. Electronic-Disc 1st	Incremental Charge - Manual Svc Order vs. Electronic-Disc Add'l
									Rec	Nonrecurring		Nonrecurring
	First	Add'l	First	Add'l	SOMEK	SOMAN	SOMAN	SOMAN	SOMAN	SOMAN		
<b>Additional Non-Recurring Charges (NRC)</b>												
	Unbundled Miscellaneous Rate Element, Tag Loop at End Use Premise			JEP9E	URETL	8.33	0.83					
	Unbundled Miscellaneous Rate Element, Tag Design Loop at End Use Premise			JEP9E	URETN	11.21	1.10					
	<b>Note 1 - Required Port for Centrex Control in 1AESS, SESS &amp; EWSD</b>											
	<b>Note 2 - Requires Interoffice Channel Mileage</b>											
	<b>Note 3 - Installation is combination of Installation charge for SL2 Loop and Port</b>											
	<b>Note 4 - Requires Specific Customer Premises Equipment</b>											
	<small>Note: Rates displayed on this schedule are subject to change without notice. See the General Terms and Conditions for more information.</small>											

**Attachment 3**  
**Network Interconnection**

## TABLE OF CONTENTS

<b>1.</b>	<b>GENERAL.....</b>	<b>3</b>
<b>2.</b>	<b>DEFINITIONS: (FOR THE PURPOSE OF THIS ATTACHMENT).....</b>	<b>3</b>
<b>3.</b>	<b>NETWORK INTERCONNECTION.....</b>	<b>5</b>
<b>4.</b>	<b>INTERCONNECTION TRUNK GROUP ARCHITECTURES.....</b>	<b>7</b>
<b>5.</b>	<b>NETWORK DESIGN AND MANAGEMENT FOR INTERCONNECTION .....</b>	<b>14</b>
<b>6.</b>	<b>LOCAL DIALING PARITY.....</b>	<b>17</b>
<b>7.</b>	<b>INTERCONNECTION COMPENSATION .....</b>	<b>17</b>
<b>8.</b>	<b>FRAME RELAY SERVICE INTERCONNECTION.....</b>	<b>23</b>
<b>9.</b>	<b>ORDERING CHARGES .....</b>	<b>26</b>
<b>10</b>	<b>BASIC 911 AND E911 INTERCONNECTION .....</b>	<b>26</b>
	<b>Rates</b>	<b>Exhibit A</b>
	<b>Basic Architecture</b>	<b>Exhibit B</b>
	<b>One Way Architecture</b>	<b>Exhibit C</b>
	<b>Two Way Architecture</b>	<b>Exhibit D</b>
	<b>Supergroup Architecture</b>	<b>Exhibit E</b>

## NETWORK INTERCONNECTION

### 1. GENERAL

- 1.1 The Parties shall provide interconnection with each other's networks for the transmission and routing of telephone exchange service (Local Traffic), ISP-bound Traffic, and exchange access (Switched Access Traffic) on the following terms:

### 2. DEFINITIONS: (FOR THE PURPOSE OF THIS ATTACHMENT)

For purposes of this attachment only, the following terms shall have the definitions set forth below:

- 2.1 **Automatic Location Identification (ALI)** is a feature by which the address associated with the calling party's telephone number (ANI) is forwarded to the PSAP for display. Access to the ALI database is described in Attachment 2 to this Agreement.
- 2.2 **Automatic Number Identification (ANI)** corresponds to the seven-digit telephone number assigned by the serving local exchange carrier.
- 2.3 **Basic 911 Service (B911)** routes a call to one centralized answering location. The attendant at the answering location obtains the pertinent information that identifies the call and the caller's needs. The attendant then determines the appropriate agency and dials a 7-digit number to transfer the caller to that agency. The calling party's emergency information is verbally relayed to the responding agency and a unit is dispatched to the caller's location.
- 2.4 **Call Termination** has the meaning set forth for "termination" in 47CFR § 51.701(d).
- 2.5 **Call Transport** has the meaning set forth for "transport" in 47 CFR § 51.701(c).
- 2.6 **Call Transport and Termination** is used collectively to mean the switching and transport functions from the Interconnection Point to the last point of switching.
- 2.7 **Common (Shared) Transport** is defined as the transport of the originating Party's traffic by the terminating Party over the terminating Party's common (shared) facilities between (1) the terminating Party's tandem switch and end office switch, (2) between the terminating Party's tandem switches, and/or (3) between the terminating Party's host and remote end office switches. All switches referred herein must be entered into the Local Exchange Routing Guide (LERG).
- 2.8 **Dedicated Interoffice Facility** is defined as a switch transport facility between a Party's Serving Wire Center and the first point of switching within the LATA on the other Party's network.

- 2.9 **End Office Switching** is defined as the function that establishes a communications path between the trunk side and line side of the End Office switch.
- 2.10 **Enhanced 911 Service** provides features not present in Basic 911 Service, including ANI and ALI display, Selective Routing (SR) and other standard and optional features.
- 2.11 **Fiber Meet** is an interconnection arrangement whereby the Parties physically interconnect their networks via an optical fiber interface at which one Party's facilities, provisioning, and maintenance responsibility begins and the other Party's responsibility ends.
- 2.12 **Final Trunk Group** is defined as the trunk group that does not carry overflow traffic.
- 2.13 **Interconnection Point (IP)** is the physical telecommunications equipment interface that interconnects the networks of BellSouth and Local Line.
- 2.14 **IntraLATA Toll Traffic** is as defined in Section 7 of this Attachment.
- 2.15 **ISP-bound Traffic** is as defined in Section 7 of this Attachment.
- 2.16 **Local Channel** is defined as a switched transport facility between a Party's Interconnection Point and the IP's Serving Wire Center.
- 2.17 **Local Traffic** is as defined in Section 7 of this Attachment.
- 2.18 **Public Safety Answering Point (PSAP)** is the answering location for 911 calls.
- 2.19 **Reciprocal Trunk Group** is defined as a one-way trunk group carrying BellSouth originated traffic to be terminated by Local Line.
- 2.20 **Serving Wire Center** is defined as the wire center owned by one Party from which the other Party would normally obtain dial tone for its IP.
- 2.21 **Selective Routing (SR)** is a standard feature that routes an E911 call from the tandem to the designated PSAP based upon the address of the ANI of the calling party.
- 2.22 **Tandem Switching** is defined as the function that establishes a communications path between two switching offices through a third switching office through the provision of trunk side to trunk side switching.
- 2.23 **Transit Traffic** is traffic originating on Local Line's network that is switched and/or transported by BellSouth and delivered to a third party's network, or traffic originating on a third party's network that is switched and/or transported by BellSouth and delivered to Local Line's network.

### 3. NETWORK INTERCONNECTION

- 3.1 This Attachment pertains only to the provision of network interconnection where Local Line owns, leases from a third party or otherwise provides its own switch(es).
- 3.2 Network interconnection may be provided by the Parties at any technically feasible point within BellSouth's network. Requests to BellSouth for interconnection at points other than as set forth in this Attachment may be made through the Bona Fide Request/New Business Request (BFR/NBR) process set out in this Agreement.
- 3.2.1 Each Party is responsible for providing, engineering and maintaining the network on its side of the IP. The IP must be located within BellSouth's serving territory in the LATA in which traffic is originating. The IP determines the point at which the originating Party shall pay the terminating Party for the Call Transport and Termination of Local Traffic, ISP-bound Traffic and IntraLATA Toll Traffic.
- 3.2.2 Pursuant to the provisions of this Attachment, the location of the initial IP in a given LATA shall be established by mutual agreement of the Parties. Subject to the requirements for installing additional IPs, as set forth below, any IPs existing prior to the Effective Date of the Agreement will be accepted as initial IPs and will not require re-grooming. When the Parties mutually agree to utilize two-way interconnection trunk groups for the exchange of Local Traffic, ISP-bound Traffic and IntraLATA Toll Traffic between each other, the Parties shall mutually agree to the location of IP(s). If the Parties are unable to agree to a mutual initial IP, each Party, as originating Party, shall establish a single IP in the LATA for the delivery of its originated Local Traffic, ISP-bound Traffic and IntraLATA Toll Traffic to the other Party for Call Transport and Termination by the terminating Party.
- 3.2.3 When first establishing the interconnection arrangement in each LATA, the location of the IP shall be established by mutual agreement of the Parties. In selecting the IP, both Parties will act in good faith and select the point that is most efficient for both Parties. If the Parties are unable to agree on the location of the IP, each Party will designate IPs for its originated traffic. Additional IP(s) in a LATA may be established by mutual agreement of the Parties. Notwithstanding the foregoing, additional IP(s) in a particular LATA shall be established, at the request of either Party, when the Local Traffic and ISP-bound Traffic exceeds 8.9 million minutes per month for three consecutive months at the proposed location of the additional IP. BellSouth will not request the establishment of an IP where physical or virtual collocation space is not available or where BellSouth fiber connectivity is not available. When the Parties agree to utilize two-way interconnection trunk groups for the exchange of Local Traffic, ISP-bound Traffic and IntraLATA Toll Traffic the Parties must agree to the location of the IP(s).

### 3.3 Interconnection via Dedicated Facilities

- 3.3.1 **Local Channel Facilities.** As part of Call Transport and Termination, the originating Party may obtain Local Channel facilities from the terminating Party. The percentage of Local Channel facilities utilized for Local Traffic shall be determined based upon the application of the Percent Local Facility (PLF) Factor on a statewide basis. The charges applied to the percentage of Local Channel facilities used for Local Traffic as determined by the PLF are as set forth in Exhibit A to this Attachment. The remaining percentage of Local Channel facilities shall be billed at BellSouth's applicable access tariff rates.
- 3.3.2 **Dedicated Interoffice Facilities.** As a part of Call Transport and Termination, the originating Party may obtain Dedicated Interoffice Facilities from the terminating Party. The percentage of Dedicated Interoffice Facilities utilized for Local Traffic shall be determined based upon the application of the Percent Local Facility (PLF) Factor on a statewide basis. The charges applied to the percentage of the Dedicated Interoffice Facilities used for Local Traffic as determined by the PLF are as set forth in Exhibit A to this Attachment. The remaining percentage of the Dedicated Interoffice Facilities shall be billed at BellSouth's applicable access tariff rates.
- 3.3.3 The facilities purchased pursuant to this Section 3 shall be ordered via the Access Service Request (ASR) process.
- 3.4 **Fiber Meet**
- 3.4.1 Notwithstanding Section 3.2.1, 3.2.2, and 3.2.3 above, if Local Line elects to establish interconnection with BellSouth pursuant to a Fiber Meet Local Channel, Local Line and BellSouth shall jointly engineer, operate and maintain a Synchronous Optical Network (SONET) transmission system by which they shall interconnect their transmission and routing of Local Traffic via a Local Channel at either the DS1 or DS3 level. The Parties shall work jointly to determine the specific transmission system. However, Local Line's SONET transmission system must be compatible with BellSouth's equipment, and the Data Communications Channel (DCC) must be turned off.
- 3.4.2 Each Party, at its own expense, shall procure, install and maintain the agreed upon SONET transmission system in its network.
- 3.4.3 The Parties shall agree to a Fiber Meet point between the BellSouth Serving Wire Center and the Local Line Serving Wire Center. The Parties shall deliver their fiber optic facilities to the Fiber Meet point with sufficient spare length to reach the fusion splice point for the Fiber Meet Point. BellSouth shall, at its own expense, provide and maintain the fusion splice point for the Fiber Meet. A building type Common Language Location Identification (CLLI) code will be established for each Fiber Meet point. All orders for interconnection facilities from the Fiber Meet point shall indicate the Fiber Meet point as the originating point for the facility.



- 3.4.4 Upon verbal request by Local Line, BellSouth shall allow Local Line access to the fusion splice point for the Fiber Meet point for maintenance purposes on Local Line's side of the Fiber Meet point.
- 3.4.5 Neither Party shall charge the other for its Local Channel portion of the Fiber Meet facility used exclusively for Local Traffic. All other appropriate charges will apply. Local Line shall be billed for a mixed use of the Local Channel using the actual traffic Local Line elects to transmit over the facility and the rates from this Agreement and the appropriate tariff(s). Charges for switched and special access services shall be billed in accordance with the applicable access service tariff.
- 4. INTERCONNECTION TRUNK GROUP ARCHITECTURES**
- 4.1 BellSouth and Local Line shall establish interconnecting trunk groups and trunk group configurations between networks, including the use of one-way or two-way trunks in accordance with the following provisions set forth in this Agreement. For trunking purposes, traffic will be routed based on the digits dialed by the originating End User and in accordance with the LERG.
- 4.2 Local Line shall establish an interconnection trunk group(s) to at least one BellSouth access tandem within the LATA for the delivery of Local Line's originated Local Traffic, ISP-bound Traffic and IntraLATA Toll Traffic and for the receipt and delivery of Transit Traffic. To the extent Local Line desires to deliver Local Traffic, ISP-bound Traffic, IntraLATA Toll Traffic and/or Transit Traffic to BellSouth access tandems within the LATA, other than the tandems(s) to which Local Line has established interconnection trunk groups, Local Line shall order Multiple Tandem Access, as described in this Attachment, to such other BellSouth access tandems.
- 4.2.1 Notwithstanding the forgoing, Local Line shall establish an interconnection trunk group(s) to all BellSouth access and local tandems in the LATA where Local Line has homed (i.e. assigned) its NPA/NXXs. Local Line shall home its NPA/NXXs on the BellSouth tandems that serve the exchange rate center areas to which the NPA/NXXs are assigned. The specified exchange rate center assigned to each BellSouth tandem is defined in the LERG. Local Line shall enter its NPA/NXX access and/or local tandem homing arrangements into the LERG.
- 4.3 Switched access traffic will be delivered to and from Interexchange Carriers (IXCs) based on Local Line's NXX access tandem homing arrangement as specified by Local Line in the LERG.
- 4.4 Any Local Line interconnection request that (1) deviates from the interconnection trunk group architectures as described in this Agreement, (2) affects traffic delivered to Local Line from a BellSouth switch, and (3) requires special BellSouth switch translations and other network modifications will require Local

Line to submit a BFR/NBR via the BFR/NBR Process as set forth in this Agreement.

- 4.5 Recurring and nonrecurring rates associated with interconnecting trunk groups between BellSouth and Local Line are set forth in Exhibit A. To the extent a rate associated with the interconnecting trunk group is not set forth in Exhibit A, the rate shall be as set forth in the appropriate BellSouth tariff for switched access services.
- 4.6 For two-way trunk groups that carry only both Parties' Local Traffic, the Parties shall be compensated at 50% of the nonrecurring and recurring rates for dedicated trunks and DS1 facilities. Local Line shall be responsible for ordering and paying for any two-way trunks carrying Transit Traffic.
- 4.7 All trunk groups will be provisioned as Signaling System 7 (SS7) capable where technically feasible. If SS7 is not technically feasible multi-frequency (MF) protocol signaling shall be used.
- 4.8 In cases where Local Line is also an IXC, the IXC's Feature Group D (FG D) trunk group(s) must remain separate from the local interconnection trunk group(s).
- 4.9 Each Party shall order interconnection trunks and trunk group including trunk and trunk group augmentations via the ASR process. A Firm Order Confirmation (FOC) shall be returned to the ordering Party, after receipt of a valid, error free ASR, within the timeframes set forth in each state's applicable Performance Measures. Notwithstanding the foregoing, blocking situations and projects shall be managed through BellSouth's Carrier Interconnection Switching Center (CISC) Project Management Group and Local Line's equivalent trunking group, and FOCs for such orders shall be returned in the timeframes applicable to the project. A project is defined as (1) a new trunk group or (2) a request for more than 96 trunks on a single or multiple group(s) in a given BellSouth local calling area.
- 4.10 **Interconnection Trunk Groups for Exchange of Local Traffic and Transit Traffic**
- Upon mutual agreement of the Parties in a joint planning meeting, the Parties' shall exchange Local Traffic on two-way interconnection trunk group(s) with the quantity of trunks being mutually determined and the provisioning being jointly coordinated. Furthermore, the Parties shall agree upon the IP(s) for two-way interconnection trunk groups transporting both Parties' Local Traffic, ISP-bound Traffic and IntraLATA Toll Traffic. Local Line shall order such two-way trunks via the Access Service Request (ASR) process. BellSouth will use the Trunk Group Service Request (TGSR) to request changes in trunking. Furthermore, the Parties shall jointly review trunk performance and forecasts on a periodic basis. The Parties' use of two-way interconnection trunk groups for the transport of Local Traffic, ISP-bound Traffic and IntraLATA Toll Traffic between the Parties

does not preclude either Party from establishing additional one-way interconnection trunks for the delivery of its originated Local Traffic, ISP-bound Traffic and IntraLATA Toll Traffic to the other Party.

4.10.1 **BellSouth Access Tandem Interconnection**

BellSouth access tandem interconnection at a single access tandem provides access to those end offices subtending that access tandem (Intratandem Access). Access tandem interconnection is available for any of the following access tandem architectures

4.10.1.1 **Basic Architecture**

In the basic architecture, Local Line's originating Local Traffic, ISP-bound Traffic and IntraLATA Toll Traffic and originating and terminating Transit Traffic is transported on a single two-way trunk group between Local Line and BellSouth access tandem(s) within a LATA to provide Intratandem Access. This trunk group carries Transit Traffic between Local Line and Independent Companies, Interexchange Carriers, other CLECs, CMRS providers that have a Meet Point Billing arrangement with BellSouth, and other network providers with which Local Line desires to exchange traffic. This trunk group also carries Local Line originated Transit Traffic transiting a single BellSouth access tandem destined to third party tandems such as an Independent Company tandem or other CLEC tandem. BellSouth originated Local Traffic, ISP-bound Traffic and IntraLATA Toll Traffic is transported on a separate single one-way trunk group terminating to Local Line. Other trunk groups for operator services, directory assistance, emergency services and intercept must be established pursuant to the applicable BellSouth tariff if service is requested. The LERG contains current routing and tandem serving arrangements. The basic Architecture is illustrated in Exhibit B.

4.10.1.2 **One-Way Trunk Group Architecture**

In one-way trunk group architecture, the Parties interconnect using three separate trunk groups. A one-way trunk group provides Intratandem Access for Local Line-originated Local Traffic, ISP-bound Traffic and IntraLATA Toll Traffic destined for BellSouth End Users. A second one-way trunk group carries BellSouth-originated Local Traffic, ISP-bound Traffic and IntraLATA Toll Traffic destined for Local Line End-Users. A two-way trunk group provides Intratandem Access for Local Line's originating and terminating Transit Traffic. This trunk group carries Transit Traffic between Local Line and Independent Companies, Interexchange Carriers, other CLECs, CMRS providers that have a Meet Point Billing arrangement with BellSouth, and other network providers with which Local Line desires to exchange traffic. This trunk group also carries Local Line originated Transit Traffic transiting a single BellSouth access tandem destined to third party tandems such as an Independent Company tandem or other CLEC tandem. BellSouth originated Local Traffic, ISP-bound Traffic and IntraLATA Toll Traffic is transported on a separate single one-way trunk group terminating to Local Line. Other trunk groups for operator services, directory assistance,

emergency services and intercept must be established pursuant to the applicable BellSouth tariff if service is requested. The LERG contains current routing and tandem serving arrangements. The one-way trunk group architecture is illustrated in Exhibit C.

#### 4.10.1.3 **Two-Way Trunk Group Architecture**

The two-way trunk group Architecture establishes one two-way trunk group to provide IntraTandem Access for the exchange of Local Traffic, ISP-bound Traffic and IntraLATA Toll Traffic between Local Line and BellSouth. In addition, a separate two-way transit trunk group must be established for Local Line's originating and terminating Transit Traffic. This trunk group carries Transit Traffic between Local Line and Independent Companies, Interexchange Carriers, other CLECs, CMRS providers that have a Meet Point Billing arrangement with BellSouth, and other network providers with which Local Line desires to exchange traffic. This trunk group also carries Local Line originated Transit Traffic transiting a single BellSouth access tandem destined to third party tandems such as an Independent Company tandem or other CLEC tandem. BellSouth originated traffic may, in order to prevent or remedy traffic blocking situations, be transported on a separate single one-way trunk group terminating to Local Line. However, where Local Line is responsive in a timely manner to BellSouth's transport needs for its originated traffic, BellSouth originating traffic will be placed on the two-way Local Traffic trunk group carrying ISP-bound Traffic and IntraLATA Toll Traffic. Other trunk groups for operator services, directory assistance, emergency services and intercept must be established pursuant to the applicable BellSouth tariff if service is requested. The LERG contains current routing and tandem serving arrangements. The two-way trunk group architecture is illustrated in Exhibit D.

#### 4.10.1.4 **Supergroup Architecture**

In the supergroup architecture, the Parties' Local Traffic, ISP-bound Traffic and IntraLATA Toll Traffic and Local Line's Transit Traffic are exchanged on a single two-way trunk group between Local Line and BellSouth to provide IntraTandem Access to Local Line. This trunk group carries Transit Traffic between Local Line and Independent Companies, Interexchange Carriers, other CLECs, CMRS providers that have a Meet Point Billing arrangement with BellSouth, and other network providers with which Local Line desires to exchange traffic. This trunk group also carries Local Line originated Transit Traffic transiting a single BellSouth access tandem destined to third party tandems such as an Independent Company tandem or other CLEC tandem. BellSouth originated traffic may, in order to prevent or remedy traffic blocking situations, be transported on a separate single one-way trunk group terminating to Local Line. However, where Local Line is responsive in a timely manner to BellSouth's transport needs for its originated traffic, BellSouth originating traffic will be placed on the Supergroup. Other trunk groups for operator services, directory assistance, emergency services and intercept must be established pursuant to the applicable BellSouth tariff if service is

requested. The LERG contains current routing and tandem serving arrangements. The supergroup architecture is illustrated in Exhibit E.

4.10.1.5 **Multiple Tandem Access Interconnection**

4.10.1.5.1 Where Local Line does not choose access tandem interconnection at every BellSouth access tandem within a LATA, Local Line may utilize BellSouth's multiple tandem access interconnection (MTA). To utilize MTA Local Line must establish an interconnection trunk group(s) at a BellSouth access tandem through multiple BellSouth access tandems within the LATA as required. BellSouth will route Local Line's originated Local Traffic, ISP-bound Traffic and IntraLATA Toll Traffic for LATA wide transport and termination. Local Line must also establish an interconnection trunk group(s) at all BellSouth access tandems where Local Line NXXs are homed as described in Section 4.2.1 above. If Local Line does not have NXXs homed at any particular BellSouth access tandem within a LATA and elects not to establish an interconnection trunk group(s) at such BellSouth access tandem, Local Line can order MTA in each BellSouth access tandem within the LATA where it does have an interconnection trunk group(s) and BellSouth will terminate Local Line's Local Traffic, ISP-bound Traffic and IntraLATA Toll Traffic to End-Users served through those BellSouth access tandems where Local Line does not have an interconnection trunk group(s). MTA shall be provisioned in accordance with BellSouth's Ordering Guidelines.

4.10.1.5.2 Local Line may also utilize MTA to route its originated Transit Traffic; provided, however, that MTA may not be utilized to route switched access traffic that transits the BellSouth network to an Interexchange Carrier (IXC). Switched access traffic originated by or terminated to Local Line will be delivered to and from IXCs based on Local Line's NXX access tandem homing arrangement as specified by Local Line in the LERG.

4.10.1.5.3 Compensation for MTA shall be at the applicable tandem switching and transport charges specified in Exhibit A to this Attachment and shall be billed in addition to any Call Transport and Termination charges.

4.10.1.5.4 To the extent Local Line does not purchase MTA in a LATA served by multiple access tandems, Local Line must establish an interconnection trunk group(s) to every access tandem in the LATA to serve the entire LATA. To the extent Local Line routes its traffic in such a way that utilizes BellSouth's MTA service without properly ordering MTA, Local Line shall pay BellSouth the associated MTA charges.

4.10.2 **Local Tandem Interconnection**

4.10.2.1 Local Tandem Interconnection arrangement allows Local Line to establish an interconnection trunk group(s) at BellSouth local tandems for: (1) the delivery of Local Line-originated Local Traffic, ISP-bound Traffic and IntraLATA Toll

Traffic transported and terminated by BellSouth to BellSouth end offices served by those BellSouth local tandems, and (2) for local Transit Traffic transported by BellSouth for third party network providers who have also established an interconnection trunk group(s) at those BellSouth local tandems.

- 4.10.2.2 When a specified local calling area is served by more than one BellSouth local tandem, Local Line must designate a "home" local tandem for each of its assigned NPA/NXXs and establish trunk connections to such local tandems. Additionally, Local Line may choose to establish an interconnection trunk group(s) at the BellSouth local tandems where it has no codes homing but is not required to do so. Local Line may deliver Local Traffic, ISP-bound Traffic and IntraLATA Toll Traffic to a "home" BellSouth local tandem that is destined for other BellSouth or third party network provider end offices subtending other BellSouth local tandems in the same local calling area where Local Line does not choose to establish an interconnection trunk group(s). It is Local Line's responsibility to enter its own NPA/NXX local tandem homing arrangements into the LERG either directly or via a vendor in order for other third party network providers to determine appropriate traffic routing to Local Line's codes. Likewise, Local Line shall obtain its routing information from the LERG.
- 4.10.2.3 Notwithstanding establishing an interconnection trunk group(s) to BellSouth's local tandems, Local Line must also establish an interconnection trunk group(s) to BellSouth access tandems within the LATA on which Local Line has NPA/NXXs homed for the delivery of Interexchange Carrier Switched Access (SWA) and toll traffic, and traffic to Type 2A CMRS connections located at the access tandems. BellSouth shall not switch SWA traffic through more than one BellSouth access tandem. SWA, Type 2A CMRS or toll traffic routed to the local tandem in error will not be backhauled to the BellSouth access tandem for completion. (Type 2A CMRS interconnection is defined in BellSouth's A35 General Subscriber Services Tariff).
- 4.10.2.4 BellSouth's provisioning of Local Tandem Interconnection assumes that Local Line has executed the necessary local interconnection agreements with the other third party network providers subtending those local tandems as required by the Act.
- 4.10.3 **Direct End Office-to-End Office Interconnection**
- 4.10.3.1 Direct End Office-to-End Office one-way or two-way interconnection trunk groups allow for the delivery of a Party's originating Local Traffic, ISP-bound Traffic and IntraLATA Toll Traffic to the terminating Party on a direct end office-to-end office basis.
- 4.10.3.2 The Parties shall utilize direct end office-to-end office trunk groups under any one of the following conditions:

- 4.10.3.2.1 Tandem Exhaust - If a tandem through which the Parties are interconnected is unable to, or is forecasted to be unable to support additional traffic loads for any period of time, the Parties will mutually agree on an end office trunking plan that will alleviate the tandem capacity shortage and ensure completion of traffic between Local Line and BellSouth.
- 4.10.3.2.2 Traffic Volume -To the extent either Party has the capability to measure the amount of traffic between Local Line's switch and a BellSouth end office and where such traffic exceeds or is forecasted to exceed a single DS1 of traffic per month, then the Parties shall install and retain direct end office trunking sufficient to handle such traffic volumes. Either Party will install additional capacity between such points when overflow traffic exceeds or is forecasted to exceed a single DS1 of traffic per month. In the case of one-way trunking, additional trunking shall only be required by the Party whose trunking has achieved the preceding usage threshold.
- 4.10.3.2.3 Mutual Agreement - The Parties may install direct end office trunking upon mutual agreement in the absence of conditions (1) or (2) above.
- 4.10.4 **Transit Traffic Trunk Group**
- Transit Traffic trunks can either be two-way trunks or two one-way trunks ordered by Local Line to deliver and receive Transit Traffic. Establishing Transit Traffic trunks at BellSouth access and local tandems provides intratandem access to the third parties also interconnected at those tandems.
- 4.10.4.1 **Toll Free Traffic**
- 4.10.4.1.1 If Local Line chooses BellSouth to perform the Service Switching Point (SSP) Function (i.e., handle Toll Free database queries) from BellSouth's switches, all Local Line originating Toll Free traffic will be routed over the Transit Traffic Trunk Group and shall be delivered using GR-394 format. Carrier Code "0110" and Circuit Code (to be determined for each LATA) shall be used for all such calls.
- 4.10.4.1.2 Local Line may choose to perform its own Toll Free database queries from its switch. In such cases, Local Line will determine the nature (local/intraLATA/interLATA) of the Toll Free call (local/IntraLATA/InterLATA) based on the response from the database. If the call is a BellSouth local or intraLATA Toll Free call, Local Line will route the post-query local or IntraLATA converted ten-digit local number to BellSouth over the local or intraLATA trunk group. If the call is a third party (ICO, IXC, CMRS or other CLEC) local or intraLATA Toll Free call, Local Line will route the post-query local or intraLATA converted ten-digit local number to BellSouth over the Transit Traffic Trunk Group and Local Line shall provide to BellSouth a Toll Free billing record when appropriate. If the query reveals the call is an interLATA Toll Free call, Local Line will route the post-query interLATA Toll Free call (1) directly from its switch for carriers interconnected with its network or (2) over the Transit Traffic Trunk

Group to carriers that are not directly connected to Local Line's network but that are connected to BellSouth's access tandem.

- 4.10.5 All post-query Toll Free calls for which Local Line performs the SSP function, if delivered to BellSouth, shall be delivered using GR-394 format for calls destined to IXCs, and GR-317 format for calls destined to end offices that directly subtend a BellSouth access tandem within the LATA.

**5. NETWORK DESIGN AND MANAGEMENT FOR INTERCONNECTION**

- 5.1 Network Management and Changes. The Parties will exchange toll-free maintenance contact numbers and escalation procedures. The Parties will provide public notice of network changes in accordance with applicable federal and state rules and regulations.

- 5.2 Interconnection Technical Standards. The interconnection of all networks will be based upon accepted industry/national guidelines for transmission standards and traffic blocking criteria. Interconnecting facilities shall conform, at a minimum, to the telecommunications industry standard of DS-1 pursuant to Telcordia Standard No. TR-NWT-00499. Where Local Line chooses to utilize Signaling System 7 signaling, also known as Common Channel Signaling (SS7), SS7 connectivity is required between the Local Line switch and the BellSouth Signaling Transfer Point (STP). BellSouth will provide SS7 signaling using Common Channel Signaling Access Capability in accordance with the technical specifications set forth in the BellSouth Guidelines to Technical Publication, TR-TSV-000905. Facilities of each Party shall provide the necessary on-hook, off-hook answer and disconnect supervision and shall provide calling number ID (Calling Party Number) when technically feasible.

- 5.3 Quality of Interconnection. The local interconnection for the transmission and routing of telephone exchange service and exchange access that each Party provides to each other will be at least equal in quality to what it provides to itself and any subsidiary or affiliate, where technically feasible, or to any other Party to which each Party provides local interconnection.

- 5.4 Network Management Controls. Both Parties will work cooperatively to apply sound network management principles by invoking appropriate network management controls (e.g., call gapping) to alleviate or prevent network congestion.

- 5.5 SS7 Signaling. Both Parties will utilize LEC-to-LEC SS7 Signaling, where available, in conjunction with all traffic in order to enable full interoperability of CLASS features and functions except for call return. All SS7 signaling parameters will be provided, including but not limited to automatic number identification (ANI), originating line information (OLI) calling company category and charge number. All privacy indicators will be honored, and the Parties will exchange



Transactional Capabilities Application Part (TCAP) messages to facilitate full interoperability of SS7-based features between the respective networks. Neither Party shall alter the SS7 parameters, or be a party to altering such parameters, or knowingly pass SS7 parameters that have been altered in order to circumvent appropriate interconnection charges.

- 5.6 **Signaling Call Information.** BellSouth and Local Line will send and receive 10 digits for Local Traffic. Additionally, BellSouth and Local Line will exchange the proper call information, i.e. originated call company number and destination call company number, CIC, and OZZ, including all proper translations for routing between networks and any information necessary for billing.
- 5.7 **Forecasting for Trunk Provisioning**
- 5.7.1 Within six (6) months after execution of this Agreement, Local Line shall provide an initial interconnection trunk group forecast for each LATA in which it plans to provide service within BellSouth's region. Upon receipt of Local Line's forecast, the Parties shall conduct a joint planning meeting to develop a joint interconnection trunk group forecast. Each forecast provided under this Section shall be deemed "Confidential Information" under the General Terms and Conditions of this Agreement.
- 5.7.1.1 At a minimum, the forecast shall include the projected quantity of Transit Trunks, Local Line-to-BellSouth one-way trunks (Local Line Trunks), BellSouth-to-Local Line one-way trunks (Reciprocal Trunk Groups) and/or two-way interconnection trunks, if the Parties have agreed to interconnect using two-way trunking to transport the Parties' Local Traffic and IntraLATA Toll Traffic. The quantities shall be projected for a minimum of six months and shall include an estimate of the current year plus the next two years total forecasted quantities. The Parties shall mutually develop Reciprocal Trunk Groups and/or two-way interconnection trunk forecast quantities.
- 5.7.1.2 All forecasts shall include, at a minimum, Access Carrier Terminal Location (ACTL), trunk group type (local/intraLATA toll, Transit, Operator Services, 911, etc.), A location/Z location (CLLI codes for Local Line location and BellSouth location where the trunks shall terminate), interface type (e.g., DS1), Direction of Signaling, Trunk Group Number, if known, (commonly referred to as the 2-6 code) and forecasted trunks in service each year (cumulative).
- 5.7.2 Once initial interconnection trunk forecasts have been developed, Local Line shall continue to provide interconnection trunk forecasts on a semiannual basis or at otherwise mutually agreeable intervals. Local Line shall use its best efforts to make the forecasts as accurate as possible based on reasonable engineering criteria. The Parties shall continue to develop Reciprocal Trunk Group and/or two-way interconnection trunk forecasts as described in Section 5.7.1.1.

5.7.3 The submitting and development of interconnection trunk forecasts shall not replace the ordering process for local interconnection trunks. Each Party shall exercise its best efforts to provide the quantity of interconnection trunks mutually forecasted. However, the provision of the forecasted quantity of interconnection trunks is subject to trunk terminations and facility capacity existing at the time the trunk order is submitted. Furthermore, the receipt and development of trunk forecasts does not imply any liability for failure to perform if capacity (trunk terminations or facilities) is not available for use at the forecasted time.

5.8 **Trunk Utilization**

5.8.1 For the Reciprocal Trunk Groups that are Final Trunk Groups (Reciprocal Final Trunk Groups), BellSouth and Local Line shall monitor traffic on each interconnection Reciprocal Final Trunk Group that is ordered and installed. The Parties agree that the Reciprocal Final Trunk Groups will be utilized at 60 percent (60%) of the time consistent busy hour utilization level within 90 days of installation. The Parties agree that the Reciprocal Final Trunk Groups will be utilized at eighty percent (80%) of the time consistent busy hour utilization level within 180 days of installation. Any Reciprocal Final Trunk Group not meeting the minimum thresholds set forth in this Section are defined as "Under-utilized" trunks. BellSouth may disconnect any Under-utilized Reciprocal Final Trunk Groups and Local Line shall refund to BellSouth the associated nonrecurring and recurring trunk and facility charges paid by BellSouth, if any.

5.8.1.1 BellSouth's CISC will notify Local Line of any under-utilized Reciprocal Trunk Groups and the number of such trunk groups that BellSouth wishes to disconnect. BellSouth will provide supporting information either by email or facsimile to the designated Local Line interface. Local Line will provide concurrence with the disconnection in seven (7) business days or will provide specific information supporting why the trunks should not be disconnected. Such supporting information should include expected traffic volumes (including traffic volumes generated due to Local Number Portability) and the timeframes within which Local Line expects to need such trunks. BellSouth's CISC Project Manager and Circuit Capacity Manager will discuss the information with Local Line to determine if agreement can be reached on the number of Reciprocal Final Trunk Groups to be removed. If no agreement can be reached, BellSouth will issue disconnect orders to Local Line. The due date of these orders will be four weeks after Local Line was first notified in writing of the underutilization of the trunk groups.

5.8.2 To the extent that any interconnection trunk group is utilized at a time-consistent busy hour of eighty percent (80%) or greater, the Parties may review the trunk groups and, if necessary, shall negotiate in good faith for the installation of augmented facilities.

5.8.3 For the two-way trunk groups, BellSouth and Local Line shall monitor traffic on each interconnection trunk group that is ordered and installed. The Parties agree

that within 90 days of the installation of the BellSouth two-way trunk or trunks, the trunks will be utilized at 60 percent (60%) of the time consistent busy hour utilization level. The Parties agree that within 180 days of the installation of a trunk or trunks, the trunks will be utilized at eighty percent (80%) of the time consistent busy hour utilization level. Any trunk or trunks not meeting the minimum thresholds set forth in this Section are defined as "Under-utilized" trunks. BellSouth will request the disconnection of any Under-utilized two-way trunk(s) and Local Line shall refund to BellSouth the associated nonrecurring and recurring trunk and facility charges paid by BellSouth, if any.

- 5.8.3.1 BellSouth's LISC will notify Local Line of any under-utilized two-way trunk groups and the number of trunks that BellSouth wishes to disconnect. BellSouth will provide supporting information either by email or facsimile to the designated Local Line interface. Local Line will provide concurrence with the disconnection in seven (7) business days or will provide specific information supporting why the two-way trunks should not be disconnected. Such supporting information should include expected traffic volumes (including traffic volumes generated due to Local Number Portability) and the timeframes within which Local Line expects to need such trunks. BellSouth's CISC Project Manager and Circuit Capacity Manager will discuss the information with Local Line to determine if agreement can be reached on the number of trunks to be removed. If no agreement can be reached, Local Line will issue disconnect orders to BellSouth. The due date of these orders will be four weeks after Local Line was first notified in writing of the underutilization of the trunk groups.
- 5.8.3.2 To the extent that any interconnection trunk group is utilized at a time-consistent busy hour of eighty percent (80%) or greater, the Parties may review the trunk groups and, if necessary, shall negotiate in good faith for the installation of augmented facilities.

## **6. LOCAL DIALING PARITY**

- 6.1 BellSouth and Local Line shall provide local and toll dialing parity, as defined in FCC rules and regulations, with no unreasonable dialing delays. Dialing parity shall be provided for all originating telecommunications services that require dialing to route a call.

## **7. INTERCONNECTION COMPENSATION**

### **7.1 Compensation for Call Transportation and Termination for Local Traffic, ISP-bound Traffic and IntraLATA Toll Traffic**

- 7.1.1 For the purposes of this Attachment and for reciprocal compensation between the Parties pursuant to this Attachment, Local Traffic is defined as any telephone call that originates in one exchange and terminates in either the same exchange, or

other local calling area associated with the originating exchange as defined and specified in Section A3 of BellSouth's General Subscriber Service Tariff.

- 7.1.1.1 Additionally, Local Traffic includes any cross boundary, voice-to-voice intrastate, interLATA or interstate, interLATA calls established as a local call by the ruling regulatory body.
- 7.1.2 ISP-bound Traffic is defined as calls to an information service provider or Internet service provider (ISP) that are dialed by using a local dialing pattern (7 or 10 digits) by a calling party in one exchange to an ISP server or modem in either the same exchange or a corresponding Extended Area Service (EAS) exchange as defined and specified in Section A3 of BellSouth's General Subscriber Service tariff. ISP-bound Traffic is not Local Traffic subject to reciprocal compensation, but instead is information access traffic subject to the FCC's jurisdiction.
- 7.1.3 Notwithstanding the definitions of Local Traffic and ISP-bound traffic above, and pursuant to the FCC's Order on Remand and Report and Order in CC Docket 99-68 released April 27, 2001 (ISP Order on Remand), BellSouth and Local Line agree to the rebuttable presumption that all combined circuit switched Local and ISP-bound Traffic delivered to BellSouth or Local Line that exceeds a 3:1 ratio of terminating to originating traffic on a statewide basis shall be considered ISP-bound traffic for compensation purposes. BellSouth and Local Line further agree to the rebuttable presumption that all combined circuit switched Local and ISP-bound Traffic delivered to BellSouth or Local Line that does not exceed a 3:1 ratio of terminating to originating traffic on a statewide basis shall be considered Local Traffic for compensation purposes.
- 7.1.4 Neither Party shall pay compensation to the other Party for per minute of use rate elements associated with the Call Transport and Termination of Local Traffic or ISP-bound Traffic.
- 7.1.5 The appropriate elemental rates set forth in Exhibit A of this Attachment shall apply for Transit Traffic as described in Sections 7.6 and 7.6.1 below and to Multiple Tandem Access as described in Section 4.10.1.5 above.
- 7.1.6 Neither Party shall represent Switched Access Traffic as Local Traffic or ISP-bound Traffic for purposes of determining compensation for the call.
- 7.1.7 IntraLATA Toll Traffic is defined as all traffic that originates and terminates within a single LATA that is not Local or ISP-bound traffic under this Attachment.
- 7.1.7.1 For terminating its intraLATA toll traffic on the other company's network, the originating Party will pay the terminating Party BellSouth's current intrastate or interstate, whichever is appropriate, terminating switched access tariff rates as set forth in BellSouth's Access Services Tariffs as filed and in effect with the FCC or

Commission. The appropriate charges will be determined by the routing of the call. Additionally, if one Party is the other Party's End User's presubscribed interexchange carrier or if one Party's End User uses the other Party as an interexchange carrier on a 101XXXX basis, the originating party will charge the other Party the appropriate BellSouth originating switched access tariff rates as set forth in BellSouth's Intrastate or Interstate Access Services Tariff as filed and in effect with the FCC or appropriate Commission.

- 7.1.8 If Local Line assigns NPA/NXXs to specific BellSouth rate centers within the LATA and assigns numbers from those NPA/NXXs to Local Line End Users physically located outside of that LATA, BellSouth traffic originating from within the LATA where the NPA/NXXs are assigned and delivered to a Local Line customer physically located outside of such LATA, shall not be deemed Local Traffic. Further, Local Line agrees to identify such interLATA traffic to BellSouth and to compensate BellSouth for originating and transporting such interLATA traffic to Local Line at BellSouth's switched access tariff rates.
- 7.2 If Local Line does not identify such interLATA traffic to BellSouth, to the best of BellSouth's ability BellSouth will determine which whole Local Line NPA/NXXs on which to charge the applicable rates for originating network access service as reflected in BellSouth's Access Service Tariff. BellSouth shall make appropriate billing adjustments if Local Line can provide sufficient information for BellSouth to determine whether or not said traffic is Local or ISP-bound Traffic.
- 7.3 **Jurisdictional Reporting**
- 7.3.1 **Percent Local Use.** Each Party shall report to the other a Percent Local Usage (PLU) factor. The application of the PLU will determine the amount of local or ISP-bound minutes to be billed to the other Party. Each Party shall update its PLU on the first of January, April, July and October of the year and shall send it to the other Party to be received no later than 30 days after the first of each such month based on local and ISP-bound usage for the past three months ending the last day of December, March, June and September, respectively. Requirements associated with PLU calculation and reporting shall be as set forth in BellSouth's Jurisdictional Factors Reporting Guide, as it is amended from time to time.
- 7.3.2 **Percent Local Facility.** Each Party shall report to the other a Percent Local Facility (PLF) factor. The application of the PLF will determine the portion of switched dedicated transport to be billed per the local jurisdiction rates. The PLF shall be applied to Multiplexing, Local Channel and Interoffice Channel Switched Dedicated Transport utilized in the provision of local interconnection trunks. Each Party shall update its PLF on the first of January, April, July and October of the year and shall send it to the other Party to be received no later than 30 days after the first of each such month to be effective the first bill period the following month, respectively. Requirements associated with PLU and PLF calculation and

reporting shall be as set forth in BellSouth's Jurisdictional Factors Reporting Guide, as it is amended from time to time.

- 7.3.3 **Percent Interstate Usage.** Each Party shall report to the other the projected Percent Interstate Usage (PIU) factor. All jurisdictional report requirements, rules and regulations for Interexchange Carriers specified in BellSouth's Intrastate Access Services Tariff will apply to Local Line. After interstate and intrastate traffic percentages have been determined by use of PIU procedures, the PLU and PLF factors will be used for application and billing of local interconnection. Each Party shall update its PIUs on the first of January, April, July and October of the year and shall send it to the other Party to be received no later than 30 days after the first of each such month, for all services showing the percentages of use for the past three months ending the last day of December, March, June and September.
- 7.3.4 Notwithstanding the provisions in Section 7.3.1, 7.3.2, and 7.3.3 above, where the terminating Party has message recording technology that identifies the jurisdiction of traffic terminated as defined in this Agreement, such information shall, at the terminating Party's option, be utilized to determine the appropriate jurisdictional reporting factors (PLU, PIU, and/or PLF), in lieu of those provided by the originating Party. In the event that the terminating Party opts to utilize its own data to determine jurisdictional reporting factors, such terminating Party shall notify the originating Party at least 15 days prior to the beginning of the calendar quarter in which the terminating Party will begin to utilize its own data. Such factors shall subject to the Dispute Resolution provisions in this Agreement, as well as the Audit provisions set forth in 7.3.5 below.
- 7.3.5 **Audits.** On thirty (30) days written notice, each Party must provide the other the ability and opportunity to conduct an annual audit to ensure the proper billing of traffic. BellSouth and Local Line shall retain records of call detail for a minimum of nine months from which the PLU, PLF and/or PIU can be ascertained. The audit shall be conducted during normal business hours at an office designated by the Party being audited. Audit requests shall not be submitted more frequently than one (1) time per calendar year. Audits shall be performed by a mutually acceptable independent auditor paid for by the Party requesting the audit. The PLF, PLU and/or PIU shall be adjusted based upon the audit results and shall apply for the quarter the audit was completed, for the quarter prior to the completion of the audit, and for the two quarters following the completion of the audit. If, as a result of an audit, either Party is found to have overstated the PLF, PLU and/or PIU by twenty percentage points (20%) or more, that Party shall reimburse the auditing Party for the cost of the audit.
- 7.4 **Compensation for 8XX Traffic**
- 7.4.1 **Compensation for 8XX Traffic.** Each Party shall pay the other the appropriate switched access charges set forth in the BellSouth intrastate or interstate switched

access tariffs. Local Line will pay BellSouth the database query charge as set forth in the BellSouth intrastate or interstate switched access tariffs as applicable.

- 7.4.2 Records for 8XX Billing. Each Party will provide to the other the appropriate records necessary for billing intraLATA 8XX customers. The records provided will be in a standard EMI format.
- 7.4.3 8XX Access Screening. BellSouth's provision of 8XX Toll Free Dialing (TFD) to Local Line requires interconnection from Local Line to BellSouth's 8XX Signal Channel Point (SCP). Such interconnections shall be established pursuant to BellSouth's Common Channel Signaling Interconnection Guidelines and Telcordia's CCS Network Interface Specification document, TR-TSV-000905. Local Line shall establish SS7 interconnection at the BellSouth Local Signal Transfer Points serving the BellSouth 8XX SCPs that Local Line desires to query. The terms and conditions for 8XX TFD are set out in BellSouth's Intrastate Access Services Tariff.
- 7.5 **Mutual Provision of Switched Access Service**
- 7.5.1 Switched Access Traffic. Switched Access Traffic is described as telephone calls requiring local transmission or switching services for the purpose of the origination or termination of Telephone Toll Service. Switched Access Traffic includes, but is not limited to, the following types of traffic: Feature Group A, Feature Group B, Feature Group C, Feature Group D, toll free access (e.g., 8XX), 900 access and their successors. Additionally, any Public Switched Telephone Network interexchange telecommunications traffic, regardless of transport protocol method, where the originating and terminating points, end-to-end points, are in different LATAs, or are in the same LATA and the Parties' Switched Access services are used for the origination or termination of the call, shall be considered Switched Access Traffic. Irrespective of transport protocol method used, a call which originates in one LATA and terminates in another LATA (i.e., the end-to-end points of the call) or in which the Parties' Switched Access Services are used for the origination or termination of the call, shall not be considered Local Traffic or ISP-bound Traffic.
- 7.5.2 If the BellSouth End User chooses Local Line as their presubscribed interexchange carrier, or if the BellSouth End User uses Local Line as an interexchange carrier on a 101XXXX basis, BellSouth will charge Local Line the appropriate BellSouth tariff charges for originating switched access services.
- 7.5.3 Where the originating Party delivers a call to the terminating Party over switched access facilities, the originating Party will pay the terminating Party terminating, switched access charges as set forth in BellSouth's Intrastate or Interstate Access Services Tariff, as appropriate.

- 7.5.4 When Local Line's end office switch provides an access service connection to or from an interexchange carrier (IXC) by a direct trunk group to the IXC utilizing BellSouth facilities, each Party will provide its own access services to the IXC and bill on a multi-bill, multi-tariff meet-point basis. Each Party will bill its own access services rates to the IXC with the exception of the interconnection charge. The interconnection charge will be billed by Local Line as the Party providing the end office function. Each party will use the Multiple Exchange Carrier Access Billing (MECAB) guidelines to establish meet point billing for all applicable traffic. The Parties shall utilize a thirty (30) day billing period.
- 7.5.4.1 When Local Line's end office subtends the BellSouth Access Tandem switch for receipt or delivery of switched access traffic and provides an access service connection to or from an IXC via BellSouth's Access Tandem switch, BellSouth, as the tandem company agrees to provide to Local Line, as the End Office Company, as defined in MECAB, at no charge, all the switched access detail usage data, recorded at the access tandem, within no more than sixty (60) days after the recording date. Each Party will notify the other when it is not feasible to meet these requirements. As business requirements change, data reporting requirements may be modified as necessary.
- 7.5.5 BellSouth, as the tandem provider company, will retain for a minimum period of sixty (60) days, access message detail sufficient to recreate any data that is lost or damaged by the tandem provider company or any third party involved in processing or transporting data.
- 7.5.6 BellSouth, as the tandem provider company, agrees to recreate the lost or damaged data within forty-eight (48) hours of notification by the other or by an authorized third party handling the data.
- 7.5.7 Any claims against BellSouth, as the tandem provider company, for unbillable or uncollectible revenue should be filed with the tandem provider company within 120 days of the usage date.
- 7.5.8 BellSouth, as the tandem provider company shall keep records of its billing activities relating to jointly-provided Intrastate and Interstate access services in sufficient detail to permit the Subsequent Billing Party to, by formal or informal review or audit, to verify the accuracy and reasonableness of the jointly-provided access billing data provided by the Initial Billing Party. Each Party agrees to cooperate in such formal or informal reviews or audits and further agrees to jointly review the findings of such reviews or audits in order to resolve any differences concerning the findings thereof.
- 7.5.9 Local Line agrees not to deliver switched access traffic to BellSouth for termination except over Local Line ordered switched access trunks and facilities.

7.6 **Transit Traffic**



7.6.1 BellSouth shall provide tandem switching and transport services for Local Line's Transit Traffic. Rates for local Transit Traffic and ISP-bound Transit Traffic shall be the applicable Call Transport and Termination charges as set forth in Exhibit A to this Attachment. Rates for Switched Access Transit Traffic shall be the applicable charges as set forth in BellSouth Interstate or Intrastate Switched Access tariffs. Billing associated with all Transit Traffic shall be pursuant to MECAB guidelines. Traffic between Local Line and Wireless Type 1 third parties shall not be treated as Transit Traffic from a routing or billing perspective. Traffic between Local Line and Wireless Type 2A or a third party CLEC utilizing BellSouth switching shall not be treated as Transit Traffic from a routing or billing perspective until BellSouth and the Wireless carrier or a third party CLEC utilizing BellSouth switching have the capability to properly meet-point-bill in accordance with MECAB guidelines.

7.6.2 The delivery of traffic that transits the BellSouth network and is transported to another carrier's network is excluded from any BellSouth billing guarantees. BellSouth agrees to deliver Transit Traffic to the terminating carrier; provided, however, that Local Line is solely responsible for negotiating and executing any appropriate contractual agreements with the terminating carrier for the exchange of Transit Traffic through the BellSouth network. BellSouth will not be liable for any compensation to the terminating carrier or to Local Line. In the event that the terminating third party carrier imposes on BellSouth any charges or costs for the delivery of Transit Traffic, Local Line shall reimburse BellSouth for such costs. Additionally, the Parties agree that any billing to a third party or other telecommunications carrier under this section shall be pursuant to MECAB procedures.

## **8. FRAME RELAY SERVICE INTERCONNECTION**

8.1 In addition to the Local Interconnection services set forth above, BellSouth will offer a network to network Interconnection arrangement between BellSouth's and Local Line's frame relay switches as set forth below. The following provisions will apply only to Frame Relay Service and Exchange Access Frame Relay Service and Managed Shared Frame Relay Service in those states in which Local Line is certified and providing Frame Relay Service as a Local Exchange Carrier and where traffic is being exchanged between Local Line and BellSouth Frame Relay Switches in the same LATA.

8.2 The Parties agree to establish two-way Frame Relay facilities between their respective Frame Relay Switches to the mutually agreed upon Frame Relay Service point(s) of interconnection (IP(s)) within the LATA. All IPs shall be within the same Frame Relay Network Serving Areas as defined in Section A40 of BellSouth's General Subscriber Service Tariff except as set forth in this Attachment.

- 8.3 Upon the request of either Party, such interconnection will be established where BellSouth and Local Line have Frame Relay Switches in the same LATA. Where there are multiple Frame Relay switches in one central office, an interconnection with any one of the switches will be considered an interconnection with all of the switches at that central office for purposes of routing packet traffic.
- 8.4 The Parties agree to provision local and intraLATA Frame Relay Service and Exchange Access Frame Relay Service and Managed Shared Frame Relay Service (both intrastate and interstate) over Frame Relay interconnection facilities between the respective Frame Relay switches and the IPs.
- 8.5 The Parties agree to assess each other reciprocal charges for the facilities that each provides to the other according to the Percent Local Circuit Use Factor (PLCU), determined as follows:
- 8.5.1 If the data packets originate and terminate in locations in the same LATA, and are consistent with the local definitions of the Agreement, the traffic is considered local. Frame Relay framed packet data is transported within Virtual Circuits (VC). For the purposes of this Agreement, if all the data packets transported within a VC remain within the LATA, then consistent with the local definitions in this Agreement, the traffic on that VC is local (Local VC).
- 8.5.2 If the originating and terminating locations of the two-way packet data traffic are not in the same LATA, the traffic on that VC is interLATA (InterLATA VC).
- 8.5.3 The PLCU is determined by dividing the total number of Local VCs, by the total number of VCs on each Frame Relay facility. To facilitate implementation, Local Line may determine its PLCU in aggregate, by dividing the total number of Local VCs in a given LATA by the total number VCs in that LATA. The Parties agree to renegotiate the method for determining PLCU, at BellSouth's request, and within 90 days, if BellSouth notifies Local Line that it has found that this method does not adequately represent the PLCU.
- 8.5.4 If there are no VCs on a facility when it is billed, the PLCU will be zero.
- 8.5.5 BellSouth will provide the circuit between the Parties' respective Frame Relay Switches. The Parties will be compensated as follows: BellSouth will invoice, and Local Line will pay, the total nonrecurring and recurring charges for the circuit based upon the rates set forth in BellSouth's Interstate Access Tariff, FCC No. 1. Local Line will then invoice, and BellSouth will pay, an amount calculated by multiplying the BellSouth billed charges for the circuit by one-half of Local Line's PLCU.
- 8.6 The Parties agree to compensate each other for Frame Relay network-to-network interface (NNI) ports based upon the NNI rates set forth in BellSouth's Interstate Access Tariff, FCC No. 1. Compensation for each pair of NNI ports will be

calculated as follows: BellSouth will invoice, and Local Line will pay, the total nonrecurring and recurring charges for the NNI port. Local Line will then invoice, and BellSouth will pay, an amount calculated by multiplying the BellSouth billed nonrecurring and recurring charges for the NNI port by Local Line's PLCU.

- 8.7 Each Party agrees that there will be no charges to the other Party for its own subscriber's Permanent Virtual Circuit (PVC) rate elements for the local PVC segment from its Frame Relay switch to its own subscriber's premises. PVC rate elements include the Data Link Connection Identifier (DLCI) and Committed Information Rate (CIR).
- 8.8 For the PVC segment between the Local Line and BellSouth Frame Relay switches, compensation for the PVC charges is based upon the rates in BellSouth's Interstate Access Tariff, FCC No. 1.
- 8.9 Compensation for PVC rate elements will be calculated as follows:
- 8.9.1 If Local Line orders a VC connection between a BellSouth subscriber's PVC segment and a PVC segment from the BellSouth Frame Relay switch to the Local Line Frame Relay switch, BellSouth will invoice, and Local Line will pay, the total nonrecurring and recurring PVC charges for the PVC segment between the BellSouth and Local Line Frame Relay switches. If the VC is a Local VC, Local Line will then invoice and BellSouth will pay, the total nonrecurring and recurring PVC charges billed for that segment. If the VC is not local, no compensation will be paid to Local Line for the PVC segment.
- 8.9.2 If BellSouth orders a Local VC connection between a Local Line subscriber's PVC segment and a PVC segment from the Local Line Frame Relay switch to the BellSouth Frame Relay switch, BellSouth will invoice, and Local Line will pay, the total nonrecurring and recurring PVC and CIR charges for the PVC segment between the BellSouth and Local Line Frame Relay switches. If the VC is a Local VC, Local Line will then invoice and BellSouth will pay the total nonrecurring and recurring PVC and CIR charges billed for that segment. If the VC is not local, no compensation will be paid to Local Line for the PVC segment.
- 8.9.3 The Parties agree to compensate each other for requests to change a PVC segment or PVC service order record, according to the Feature Change charge as set forth in the BellSouth access tariff BellSouth Tariff FCC No. 1.
- 8.9.4 If Local Line requests a change, BellSouth will invoice and Local Line will pay a Feature Change charge for each affected PVC segment.
- 8.9.4.1 If BellSouth requests a change to a Local VC, Local Line will invoice and BellSouth will pay a Feature Change charge for each affected PVC segment.

- 8.9.5 The Parties agree to limit the sum of the CIR for the VCs on a DS1 NNI port to not more than three times the port speed, or not more than six times the port speed on a DS3 NNI port.
- 8.9.6 Except as expressly provided herein, this Agreement does not address or alter in any way either Party's provision of Exchange Access Frame Relay Service, Managed Shared Frame Relay Service or interLATA Frame Relay Service. All charges by each Party to the other for carriage of Exchange Access Frame Relay Service or interLATA Frame Relay Service are included in the BellSouth access tariff BellSouth Tariff FCC No. 1.
- 8.10 Local Line will identify and report quarterly to BellSouth the PLCU of the Frame Relay facilities it uses, per Section 8.5.3 above.
- 8.11 Either Party may request a review or audit of the various service components, consistent with the provisions of section E2 of the BellSouth State Access Services tariffs or Section 2 of the BellSouth FCC No.1 Tariff.

**9. ORDERING CHARGES**

- 9.1 The terms, conditions and rates for Ordering Charges are as set forth in FCC Tariff for Access Service Records.

**10 BASIC 911 AND E911 INTERCONNECTION**

- 10.1 Basic 911 and E911 provides a caller access to the applicable emergency service bureau by dialing 911.
- 10.2 Basic 911 Interconnection. BellSouth will provide to Local Line a list consisting of each municipality that subscribes to Basic 911 service. The list will also provide, if known, the E911 conversion date for each municipality and, for network routing purposes, a ten-digit directory number representing the appropriate emergency answering position for each municipality subscribing to 911. Local Line will be required to arrange to accept 911 calls from its end users in municipalities that subscribe to Basic 911 service and translate the 911 call to the appropriate 10-digit directory number as stated on the list provided by BellSouth. Local Line will be required to route that call to BellSouth at the appropriate 911 tandem. When a municipality converts to E911 service, Local Line will be required to begin using E911 procedures.
- 10.3 E911 Interconnection. Local Line shall install a minimum of two dedicated trunks originating from its Serving Wire Center and terminating to the appropriate E911 tandem. The Serving Wire Center must be in the same LATA as the E911 tandem. The dedicated trunks shall be, at a minimum, DS0 level trunks configured as part of a digital (1.544 Mb/s) interface (DS1 facility). The configuration shall

use CAMA-type signaling with multifrequency (MF) pulsing that will deliver ANI with the voice portion of the call. If the user interface is digital, MF pulses as well as other AC signals shall be encoded per the u-255 Law convention. Local Line will be required to provide BellSouth daily updates to the E911 database. Local Line will be required to forward 911 calls to the appropriate E911 tandem along with ANI based upon the current E911 end office to tandem homing arrangement as provided by BellSouth. If the E911 tandem trunks are not available, Local Line will be required to route the call to a designated 7-digit or 10-digit local number residing in the appropriate Public Service Answering Point (PSAP). This call will be transported over BellSouth's interoffice network and will not carry the ANI of the calling party. Local Line shall be responsible for providing BellSouth with complete and accurate data for submission to the 911/E911 database for the purpose of providing 911/E911 to its end users.

- 10.4 Rates. BellSouth will impose applicable charges on Local Line for BellSouth trunking arrangements. Rates for trunking arrangements are as set forth in Exhibit A of this Attachment. In addition Local Line will be responsible for charges for the facilities that the E911 trunks will ride. Facility rates are as set forth in the access tariff.
- 10.5 The detailed practices and procedures for 911/E911 interconnection are contained in the E911 Local Exchange Carrier Guide For Facility-Based Providers as amended from time to time during the term of this Agreement.

Exhibit B

# Basic Architecture

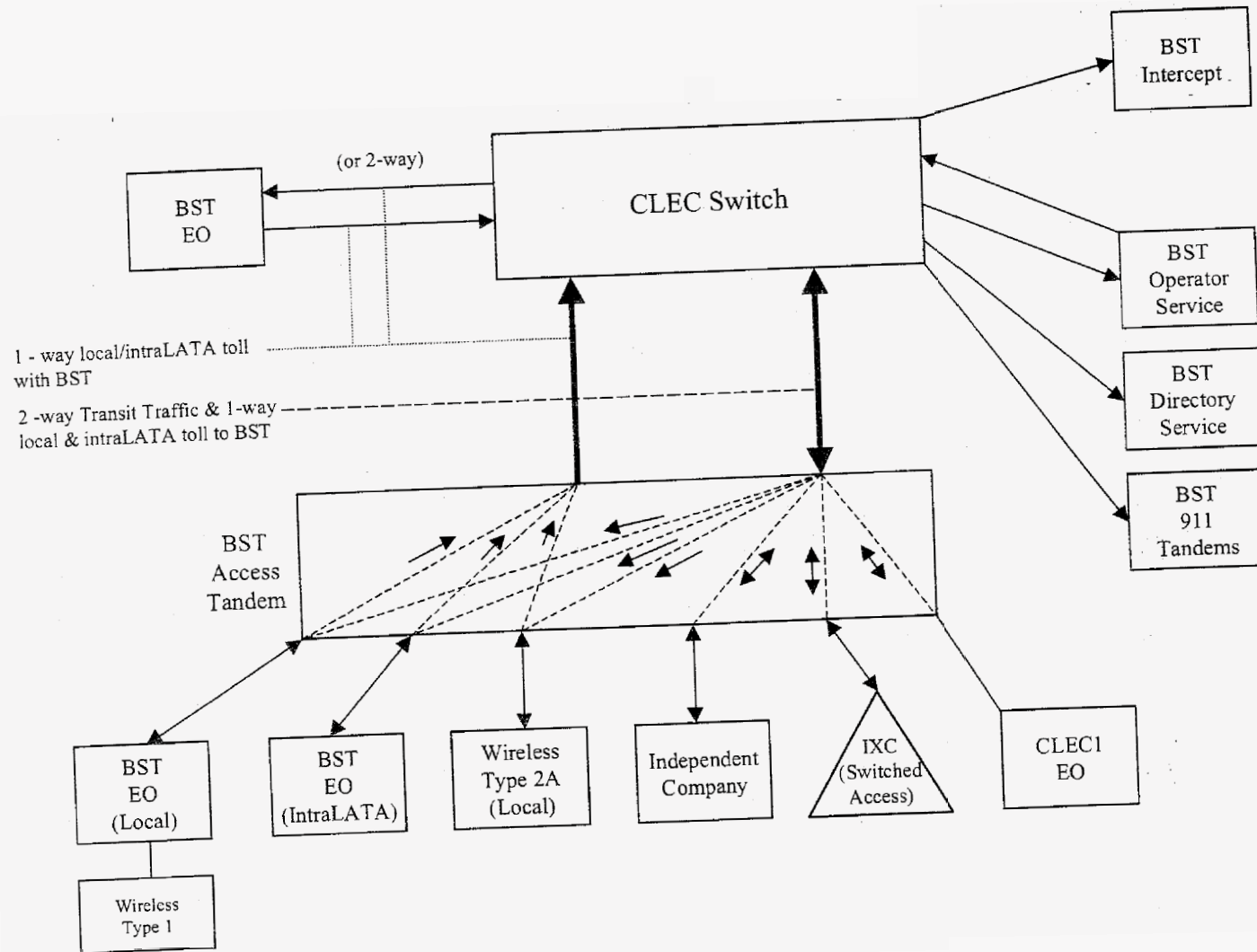

Exhibit C

# One-Way Architecture

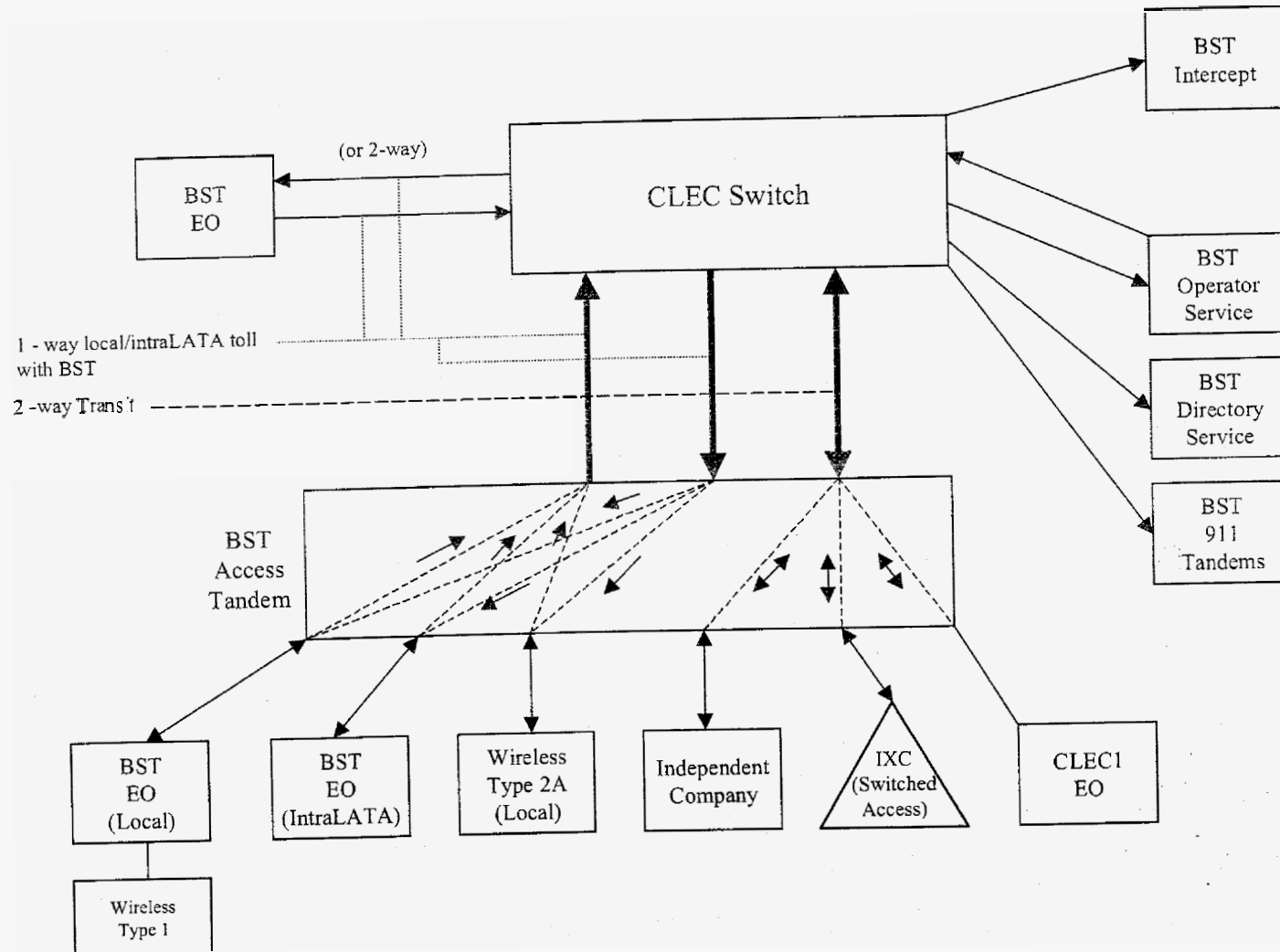
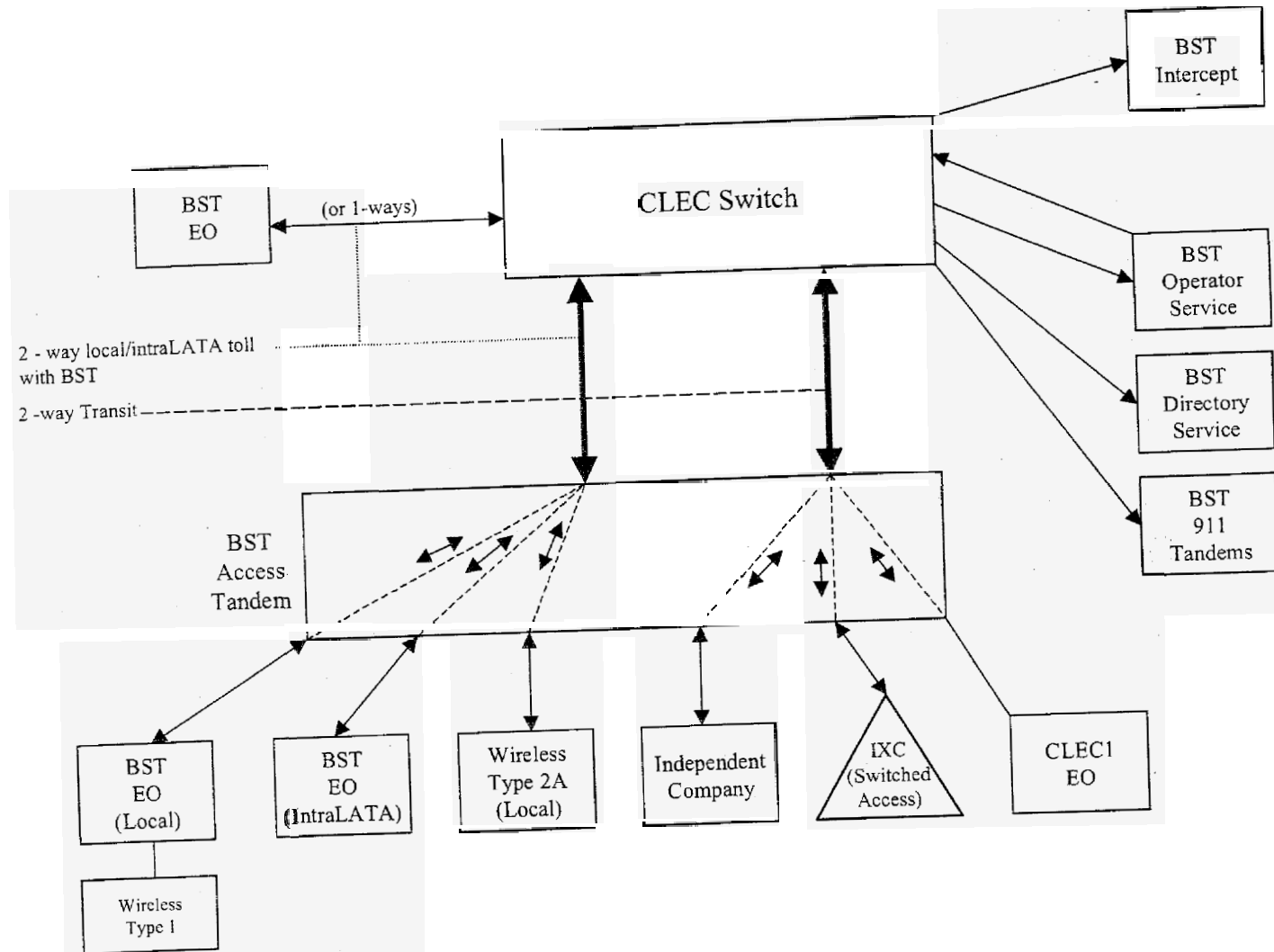

Exhibit D

# Two-Way Architecture





# Supergroup Architecture

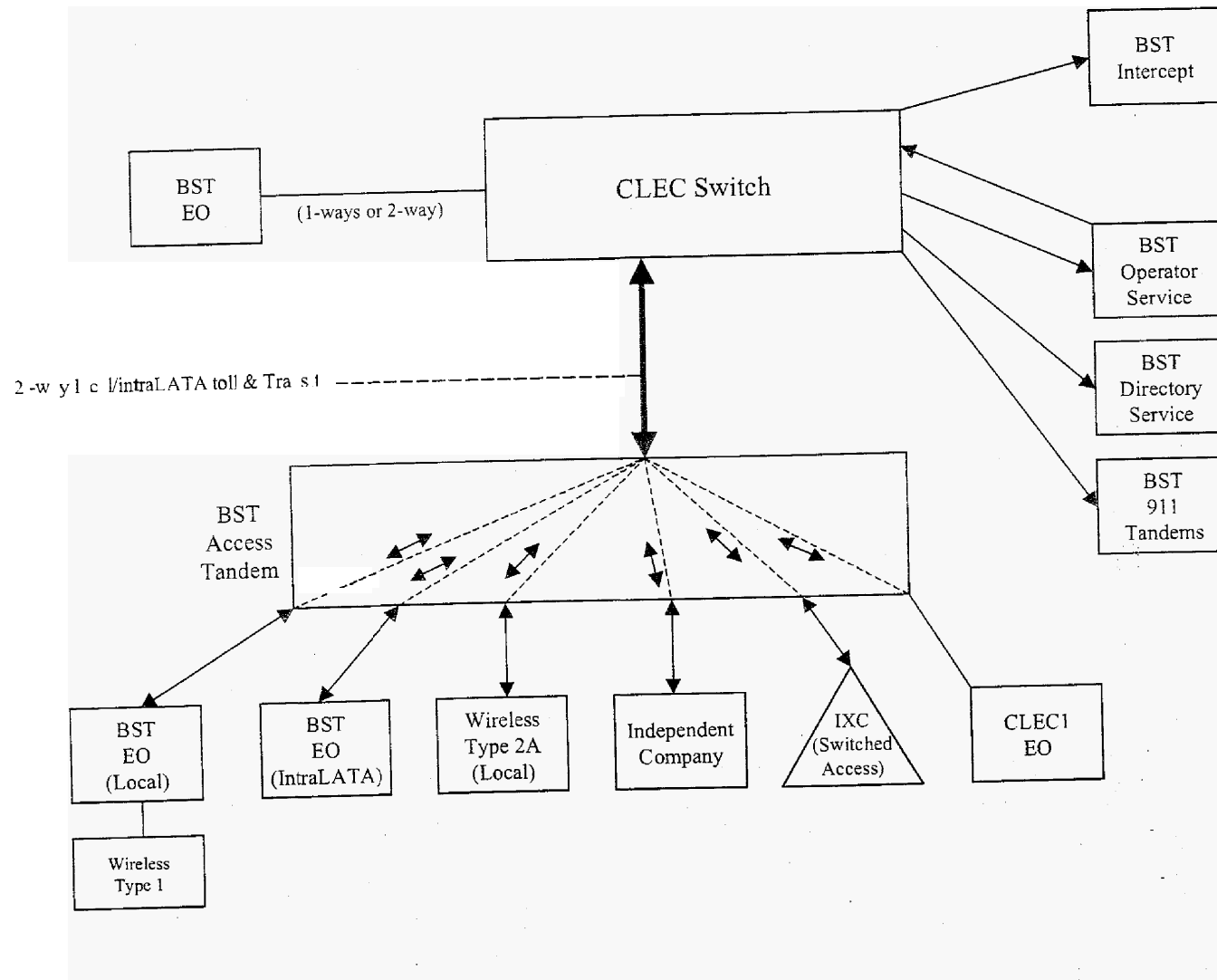

LOCAL INTERCONNECTION - Florida										Attachment: 3		Exhibit: A			
CATEGORY	RATE ELEMENTS	Interim	Zone	BCS	USOC	RATES (\$)				Svc Order Submitted Elec per LSR	Svc Order Submitted Manually per LSR	Incremental Charge - Manual Svc Order vs. Electronic-1st	Incremental Charge - Manual Svc Order vs. Electronic-Add'l	Incremental Charge - Manual Svc Order vs. Electronic-Disc 1st	Incremental Charge - Manual Svc Order vs. Electronic-Disc Add'l
						Rec	Nonrecurring		Nonrecurring Disconnect						
							First	Add'l	First	Add'l	SOME C	SOMAN	SOMAN	SOMAN	SOMAN
<b>LOCAL INTERCONNECTION (CALL TRANSPORT AND TERMINATION)</b>															
NOTE: "bk" beside a rate indicates that the Parties have agreed to bill and keep for that element pursuant to the terms and conditions in Attachment 3.															
<b>TANDEM SWITCHING</b>															
	Tandem Switching Function Per MOU			OHD		0.0006019bk									
	Multiple Tandem Switching, per MOU (applies to initial tandem only)			OHD		0.0006019									
	Tandem Intermediary Charge, per MOU*			OHD		0.0025									
* This charge is applicable only to transit traffic and is applied in addition to applicable switching and/or interconnection charges.															
<b>TRUNK CHARGE</b>															
	Installation Trunk Side Service - per DS0			OHD	TPP6X		21.73	8.19							
	Installation Trunk Side Service - per DS0			OHD	TPP9X		21.73	8.19							
	Dedicated End Office Trunk Port Service-per DS0**			OHD	TDEOP	0.00									
	Dedicated End Office Trunk Port Service-per DS1**			OH1	OH1MS	0.00									
	Dedicated Tandem Trunk Port Service-per DS0**			OHD	TDWOP	0.00									
	Dedicated Tandem Trunk Port Service-per DS1**			OH1	OH1MS	0.00									
** This rate element is recovered on a per MOU basis and is included in the End Office Switching and Tandem Switching, per MOU rate elements															
<b>COMMON TRANSPORT (Shared)</b>															
	Common Transport - Per Mile, Per MOU			OHD		0.0000035bk									
	Common Transport - Facilities Termination Per MOU			OHD		0.0004372bk									
<b>LOCAL INTERCONNECTION (DEDICATED TRANSPORT)</b>															
<b>INTEROFFICE CHANNEL - DEDICATED TRANSPORT</b>															
	Interoffice Channel - Dedicated Transport - 2-Wire Voice Grade - Per Mile per month			OHM	1L5NF	0.0091									
	Interoffice Channel - Dedicated Transport - 2-Wire Voice Grade - Facility Termination per month			OHM	1L5NF	25.32	47.35	31.78	18.31	7.03					
	Interoffice Channel - Dedicated Transport - 56 kbps - per mile per month			OHM	1L5NK	0.0091									
	Interoffice Channel - Dedicated Transport - 56 kbps - Facility Termination per month			OHM	1L5NK	18.44	47.35	31.78	18.31	7.03					
	Interoffice Channel - Dedicated Transport - 64 kbps - per mile per month			OHM	1L5NK	0.0091									
	Interoffice Channel - Dedicated Transport - 64 kbps - Facility Termination per month			OHM	1L5NK	18.44	47.35	31.78	18.31	7.03					
	Interoffice Channel - Dedicated Channel - DS1 - Per Mile per month			OH1, OH1MS	1L5NL	0.1856									
	Interoffice Channel - Dedicated Transport - DS1 - Facility Termination per month			OH1, OH1MS	1L5NL	88.44	105.54	98.47	21.47	19.05					
	Interoffice Channel - Dedicated Transport - DS3 - Per Mile per month			OH3, OH3MS	1L5NM	3.87									
	Interoffice Channel - Dedicated Transport - DS3 - Facility Termination per month			OH3, OH3MS	1L5NM	1,071.00	335.46	219.28	72.03	70.56					
<b>LOCAL CHANNEL - DEDICATED TRANSPORT</b>															
	Local Channel - Dedicated - 2-Wire Voice Grade per month			OHM	TEFV2	19.66	265.84	46.97	37.63	4.00					
	Local Channel - Dedicated - 4-Wire Voice Grade per month			OHM	TEFV4	20.45	266.54	47.67	44.22	5.33					
	Local Channel - Dedicated - DS1 per month			OH1	TEFHG	36.49	216.65	183.54	24.30	16.95					
	Local Channel - Dedicated - DS3 Facility Termination per month			OH3	TEFHJ	531.91	556.37	343.01	139.13	96.84					
<b>LOCAL INTERCONNECTION MID-SPAN MEET</b>															
NOTE: If Access service ride Mid-Span Meet, one-half the tariffed service Local Channel rate is applicable.															
	Local Channel - Dedicated - DS1 per month			OH1MS	TEFHG	0.00	0.00								
	Local Channel - Dedicated - DS3 per month			OH3MS	TEFHJ	0.00	0.00								
<b>MULTIPLEXERS</b>															
	Channelization - DS1 to DS0 Channel System			OH1, OH1MS	SATN1	146.77	101.42	71.82	11.09	10.49					
	DS3 to DS1 Channel System per month			OH3, OH3MS	SATNS	211.19	199.28	118.64	40.34	39.07					
	DS3 Interface Unit (DS1 COC) per month			OH1, OH1MS	SATCO	13.76	10.07	7.08							
Notes: If no rate is identified in the contract, the rates, terms, and conditions for the specific service or function will be as set forth in applicable BellSouth tariff.															

**Attachment 4**  
**Physical Collocation**

**BELLSOUTH**  
**PHYSICAL COLLOCATION**

**1. Scope of Attachment**

1.1 The rates, terms, and conditions contained within this Attachment shall only apply when Local Line is physically collocated as a sole occupant or as a Host within a "BellSouth Premises" location pursuant to this Attachment. "BellSouth Premises" include BellSouth Central Offices and Serving Wire Centers (hereinafter "BellSouth Premises"). This Attachment is applicable to "BellSouth Premises" owned or leased by BellSouth. However, if the "BellSouth Premises" occupied by BellSouth is leased by BellSouth from a third party, special considerations and intervals may apply in addition to the terms and conditions contained in this Attachment.

1.2 Right to Occupy. BellSouth shall offer to Local Line collocation on rates, terms, and conditions that are just, reasonable, non-discriminatory and consistent with the rules of the FCC. Subject to the rates, terms and conditions of this Attachment, where space is available and it is technically feasible, BellSouth will allow Local Line to occupy a certain area designated by BellSouth within a "BellSouth Premises", or on BellSouth property upon which the "BellSouth Premises" is located, of a size which is specified by Local Line and agreed to by BellSouth (hereinafter "Collocation Space"). The necessary rates, terms and conditions for h premises as defined by the FCC, other than BellSouth Premises, shall be negotiated upon reasonable request for collocation at such premises.

1.2.1 Neither BellSouth nor any of BellSouth's affiliates may reserve space for future use on more preferential terms than those set forth in this Attachment.

1.2.1.1 In all states other than Florida, the size specified by Local Line may contemplate a request for space sufficient to accommodate Local Line's growth within a twenty-four (24) month period.

1.2.1.2 In the state of Florida, the size specified by Local Line may contemplate a request for space sufficient to accommodate Local Line's growth within an eighteen (18) month period.

1.3 Space Allocation. BellSouth shall attempt to accommodate Local Line's requested space preferences, if any. In allocating Collocation Space, BellSouth shall not materially increase Local Line's cost or materially delay Local Line's occupation and use of the Collocation Space, assign Collocation Space that will impair the quality of service or otherwise limit the service Local Line wishes to offer, reduce unreasonably the total space available for physical collocation or preclude unreasonable physical collocation within the "BellSouth Premises". Space shall not be available for collocation if it is: (a) physically occupied by non-obsolete equipment; (b) assigned to another collocated telecommunications carrier; (c) used to provide physical access to

Version 3Q03: 11/12/2003

occupied space; (d) used to enable technicians to work on equipment located within occupied space; (e) properly reserved for future use, either by BellSouth or another collocated telecommunications carrier; or (f) essential for the administration and proper functioning of the "BellSouth Premises". BellSouth may segregate Collocation Space and require separate entrances for collocated telecommunications carriers to access their Collocation Space, pursuant to FCC Rules.

- 1.4 Space Reclamation. In the event of space exhaust within a "BellSouth Premises", BellSouth may include in its documentation for the Petition for Waiver filed with the Commission, any unutilized space in the "BellSouth Premises", including unutilized space held by Local Line and other collocated telecommunications carriers in BellSouth's Premises. Local Line will be responsible for the justification of unutilized space within its Collocation Space, if the Commission requires such justification.
- 1.4.1 If physical Collocation Space is needed to accommodate another telecommunication carrier's request for physical collocation or BellSouth's own immediate space needs, BellSouth may reclaim from Local Line any physical Collocation Space that is not being "efficiently used" or that cannot be proven to be needed within the two (2) year (18 months in Florida) planning period. This term ("efficiently used") shall mean that substantially all of the floor space is taken up by Local Line's collocated equipment as described in Section 5.1 of this Attachment. In addition, BellSouth may reclaim, for the same reasons as those stated above, any space that is not being used at all to house Local Line's equipment and/or facilities for collocation purposes. Local Line will have one hundred eighty (180) calendar days from receipt of notice by BellSouth to Local Line of the need for such physical Collocation Space to ensure that such space is being used in accordance with the terms and conditions herein and shall be responsible to justify to the Commission, if the Commission requires such justification.
- 1.5 Use of Space. Local Line shall use the Collocation Space for the purpose of installing, maintaining and operating Local Line's equipment (including testing and monitoring equipment) necessary for interconnection with BellSouth's services/facilities or for accessing BellSouth's unbundled network elements for the provision of telecommunications services, as specifically set forth in this Agreement. The Collocation Space assigned to Local Line may not be used for any purposes other than as specifically described herein or in any amendment hereto.
- 1.6 Rates and Charges. Local Line agrees to pay the rates and charges identified in Exhibit B attached hereto.
- 1.7 If any due date contained in this Attachment falls on a weekend or a National holiday, the due date will be the next business day thereafter. For intervals of ten (10) calendar days or less, National holidays will be excluded.
- 1.8 The Parties agree to comply with all applicable federal, state, county, local and administrative laws, rules, ordinances, regulations and codes in the performance of their obligations hereunder.

Version 3Q03: 11/12/2003

## 2. **Space Availability Report**

2.1 **Space Availability Report.** Upon request from Local Line and at the Local Line's expense, BellSouth will provide a written report (Space Availability Report) describing in detail the space that is currently available for collocation at a particular "BellSouth Premises". This report will include the amount of Collocation Space available at the "BellSouth Premises" requested, the number of collocators present at the "BellSouth Premises"; any modifications in the use of the space since the last report on the "BellSouth Premises" requested and the measures BellSouth is taking to make additional space available for collocation arrangements. A Space Availability Report does not reserve space at the "BellSouth Premises" for which the Space Availability Report was requested by Local Line.

2.1.1 The request from Local Line for a Space Availability Report must be in writing and include the "BellSouth Premises" street address, as identified in the Local Exchange Routing Guide (LERG) and Common Language Location Identification (CLLI) code of the "BellSouth Premises". CLLI code information is located in the National Exchange Carrier Association (NECA) Tariff FCC No. 4.

2.1.2 BellSouth will respond to a request for a Space Availability Report for a particular "BellSouth Premises" within ten (10) calendar days of the receipt of such a request. BellSouth will make its best efforts to respond in ten (10) calendar days to a Space Availability Report request when the request includes from two (2) to five (5) "BellSouth Premises" within the same state. The response time for Space Availability Report requests of more than five (5) "BellSouth Premises", whether the request are for the same state or for two or more states within the BellSouth Region, shall be negotiated between the Parties. If BellSouth cannot meet the ten (10) calendar day response time, BellSouth shall notify Local Line and inform Local Line of the timeframe under which it can respond.

## 3. **Collocation Options**

3.1 **Cageless.** BellSouth shall allow Local Line to collocate Local Line's equipment and facilities without requiring the construction of a cage or similar structure. BellSouth shall allow Local Line to have direct access to Local Line's equipment and facilities in accordance with Section 5.9. BellSouth shall make cageless collocation available in single bay increments. Except where Local Line's equipment requires special technical considerations (e.g., special cable racking or isolated ground plane), BellSouth shall assign cageless Collocation Space in conventional equipment rack lineups where feasible. For equipment requiring special technical considerations, Local Line must provide the equipment layout, including spatial dimensions for such equipment pursuant to generic requirements contained in Telcordia GR-63-Core, and shall be responsible for compliance with all special technical requirements associated with such equipment.

- 3.2 Caged. At Local Line's expense, Local Line will arrange with a Supplier certified by BellSouth (BellSouth Certified Supplier) to construct a collocation arrangement enclosure in accordance with BellSouth's Technical References (TRs) (hereinafter referred to as Specifications) prior to starting equipment installation. BellSouth will provide Specifications upon request. Where local building codes require enclosure specifications more stringent than BellSouth's enclosure Specifications, Local Line and Local Line's BellSouth Certified Supplier must comply with the more stringent local building code requirements. Local Line's BellSouth Certified Supplier shall be responsible for filing and obtaining any and all necessary permits and/or licenses for such construction. BellSouth shall cooperate with Local Line and provide, at Local Line's expense, the documentation, including existing building architectural drawings, enclosure drawings, and Specifications required and necessary for Local Line's BellSouth Certified Supplier to obtain all necessary permits and/or other licenses. Local Line's BellSouth Certified Supplier shall bill Local Line directly for all work performed for Local Line to comply with this Attachment. BellSouth shall have no liability for, nor responsibility to pay, such charges imposed by Local Line's BellSouth Certified Supplier. Local Line must provide the local BellSouth Central Office Building Contact with two (2) Access Keys that will allow entry into the locked enclosure. Except in the case of an emergency, BellSouth will not access Local Line's locked enclosure prior to notifying Local Line at least forty-eight (48) hours or two (2) business days, whichever is greater, before access to the Collocation Space is required. Upon request, BellSouth shall construct the enclosure for Local Line.
- 3.2.1 BellSouth may elect to review Local Line's plans and specifications prior to allowing construction to start, to ensure compliance with BellSouth's Specifications. BellSouth will notify Local Line of its desire to execute this review in BellSouth's response to the Initial Application, if Local Line has indicated its desire to construct its own enclosure. If Local Line's Initial Application does not indicate its desire to construct its own enclosure, but its subsequent firm order does indicate its desire to construct its own enclosure, then notification to review will be given within ten (10) calendar days after the date the firm order has been received by BellSouth. **BellSouth shall** complete its review within fifteen (15) calendar days after the receipt of Local Line's plans and specifications. Regardless of whether or not BellSouth elects to review Local Line's plans and specifications, BellSouth reserves the right to inspect the enclosure after construction has been completed to ensure that it is constructed according to Local Line's submitted plans and specifications and/or BellSouth's Specifications, as applicable. If BellSouth decides to inspect the constructed Collocation Space, BellSouth will complete its inspection within fifteen (15) calendar days after receipt of written notification of completion of the enclosure from Local Line. BellSouth shall require Local Line to remove or correct within seven (7) calendar days, at Local Line's expense, any structure that does not meet Local Line's plans and specifications or BellSouth's Specifications, as applicable.
- 3.3 Shared Caged Collocation. Local Line may allow other telecommunications carriers to share Local Line's caged collocation arrangement, pursuant to the terms and conditions agreed to by Local Line (Host) and the other telecommunications carriers

(Guests) contained in this Section, except where the "BellSouth Premises" is located within a leased space and BellSouth is prohibited by said lease from offering such an option to Local Line. BellSouth shall be notified in writing by Local Line upon the execution of any agreement between the Host and its Guest(s) within ten (10) calendar days of its execution and prior to the submission of any Firm Orders. Further, such notification shall include the name of the Guest(s), the term of the agreement, and a certification by Local Line that said agreement imposes upon the Guest(s) the same terms and conditions for Collocation Space as set forth in this Attachment between BellSouth and Local Line. The term of the agreement between the Host and its Guest(s) shall not exceed the term of this Attachment between BellSouth and Local Line.

- 3.3.1 Local Line, as the Host, shall be the sole interface and responsible Party to BellSouth for the assessment and billing of rates and charges contained within this Attachment. Local Line is also responsible for ensuring that the safety and security requirements of this Attachment are fully complied with by the Guest(s), its employees and agents. BellSouth shall provide Local Line with a proration of the costs of the Collocation Space based on the number of collocators and the space used by each. There will be a minimum charge of one (1) bay/rack per Host/Guest. In addition to the above, for all states other than Florida, Local Line shall be the responsible party to BellSouth for the purpose of submitting applications for initial and additional equipment placement for the Guest(s). In Florida, the Guest(s) may submit its own initial and subsequent equipment placement applications using the Host's Access Carrier Name Abbreviation (ACNA). A separate Guest application shall result in the assessment of an Initial Application Fee or a Subsequent Application Fee, as set forth in Exhibit B, which will be billed to the Host on the date that BellSouth provides its written response to the Guest(s) Bona Fide Application (Application Response).
- 3.3.2 Notwithstanding the foregoing, the Guest(s) may submit service orders directly to BellSouth to request the provisioning of interconnecting facilities between BellSouth and the Guest(s), the provisioning of services, and access to unbundled network elements. The bill for these interconnecting facilities, services and UNEs will be charged to the Guest(s) pursuant to the applicable Tariff or the Guest's Interconnection Agreement with BellSouth.
- 3.3.3 Local Line shall indemnify and hold harmless BellSouth from any and all claims, actions, causes of action, of whatever kind or nature arising out of the presence of Local Line's Guest(s) in the Collocation Space, except to the extent caused by BellSouth's sole negligence, gross negligence, or willful misconduct.
- 3.4 Adjacent Collocation. Subject to technical feasibility and space availability, BellSouth will permit an adjacent collocation arrangement (Adjacent Arrangement) on "BellSouth Premises" property only when space within the requested "BellSouth Premises" is legitimately exhausted and where the Adjacent Arrangement does not interfere with access to existing or planned structures or facilities on the "BellSouth Premises" property. An Adjacent Arrangement shall be procured by Local Line or



constructed by the Local Line's BellSouth Certified Supplier and must be in conformance with BellSouth's design and construction Specifications. Further, Local Line shall construct, procure, maintain and operate said Adjacent Arrangement(s) pursuant to all of the rates, terms and conditions set forth in this Attachment.

- 3.4.1 If Local Line requests Adjacent Collocation, pursuant to the conditions stated in 3.4 above, Local Line must arrange with a BellSouth Certified Supplier to construct the Adjacent Arrangement structure in accordance with BellSouth's Specifications. BellSouth will provide the appropriate Specifications upon request. Where local building codes require enclosure specifications more stringent than BellSouth's Specifications, Local Line and Local Line's BellSouth Certified Supplier shall comply with the more stringent local building code requirements. Local Line's BellSouth Certified Supplier shall be responsible for filing and receiving any and all necessary zoning, permits and/or licenses for such construction. Local Line's BellSouth Certified Supplier shall bill Local Line directly for all work performed for Local Line to comply with this Attachment. BellSouth shall have no liability for, nor responsibility to pay, such charges imposed by Local Line's BellSouth Certified Supplier. Local Line must provide the local BellSouth Central Office Building Contact with two (2) cards, keys or other access devices used to gain entry into the locked enclosure. Except in the case of an emergency, BellSouth will not access Local Line's locked enclosure prior to notifying Local Line at least forty-eight (48) hours or two (2) business days, whichever is greater, before access to the Collocation Space is required.
- 3.4.2 Local Line must submit its Adjacent Arrangement construction plans and specifications to BellSouth when it places its firm order. BellSouth shall review Local Line's plans and specifications prior to the construction of an Adjacent Arrangement(s) to ensure Local Line's compliance with BellSouth's Specifications. BellSouth shall complete its review within fifteen (15) calendar days after receipt of the plans and specifications from Local Line for the Adjacent Arrangement. BellSouth may inspect the Adjacent Arrangement during and after construction is completed to ensure that it is constructed according to Local Line's submitted plans and specifications. If BellSouth decides to inspect the completed Adjacent Arrangement, BellSouth will complete its inspection within fifteen (15) calendar days after receipt of written notification of completion of the enclosure from Local Line. BellSouth shall require Local Line to remove or correct within seven (7) calendar days, at Local Line's expense, any structure that does not meet its submitted plans and specifications or BellSouth's Specifications, as applicable.
- 3.4.3 Local Line shall provide a concrete pad, the structure housing the arrangement, heating/ventilation/air conditioning (HVAC), lighting, and all of the facilities that are required to connect the structure (i.e., racking, conduits, etc.) to the BellSouth point of demarcation. At Local Line's option, and where the local authority having jurisdiction permits, BellSouth shall provide an AC power source and access to physical collocation services and facilities, subject to the same nondiscriminatory requirements as those applicable to any other physical collocation arrangement. Local

Line's BellSouth Certified Supplier shall be responsible, at Local Line's sole expense, for filing and obtaining any and all necessary permits and/or licenses for an Adjacent Arrangement. BellSouth shall allow Shared Caged Collocation within an Adjacent Arrangement, pursuant to the terms and conditions set forth in Section 3.3 above.

- 3.5 Direct Connect. BellSouth will permit Local Line to directly interconnect between its own virtual/physical Collocation Space within the same central office by utilizing a Direct Connect. Local Line shall contract with a BellSouth Certified Supplier to place the Direct Connect, which shall be provisioned using facilities owned by Local Line. Local Line-provisioned DC's shall utilize BellSouth common cable support structure. There will be a recurring charge per linear foot, and a nonrecurring charge per cable, of the actual common cable support structure used by Local Line to provision the Direct Connects between its virtual/physical Collocation Spaces. In those instances where Local Line's virtual/physical Collocation Space is contiguous in the central office, Local Line will have the option of using Local Line's own technicians to deploy the Direct Connects using either electrical or optical facilities between its Collocation Spaces by constructing its own dedicated cable support structure. Local Line will deploy such electrical or optical connections directly between its own facilities without being routed through BellSouth's equipment. Local Line may not self-provision Direct Connects on any BellSouth distribution frame, POT, DSX (Digital System Cross-Connect) or LGX (Light Guide Cross-Connect). Local Line is responsible for ensuring the integrity of the signal.

- 3.5.1 To place an order for Direct Connects, Local Line must submit an Initial Application or Subsequent Application. If no modification to the Collocation Space is requested other than the placement of Direct Connects, the Subsequent Application Fee for Direct Connects, as defined in Exhibit B, will apply. If other modifications, in addition to the placement of Direct Connects are requested, either an Initial Application Fee or Subsequent Application Fee will apply, pursuant to Section 6.3.1 of this Attachment. This non-recurring fee will be billed by BellSouth on the date that BellSouth provides an Application Response to Local Line.

- 3.6 Co-Carrier Cross Connect (CCXC). The primary purpose of collocation is for a telecommunications carrier to interconnect with BellSouth's network or to access BellSouth's unbundled network elements for the provision of telecommunications services. BellSouth will permit Local Line to interconnect between its virtual or physical collocation arrangement(s) and that (those) of another collocated telecommunications carrier within the same "BellSouth Premises". Both Local Line's agreement and the other collocated telecommunications carrier's agreement must contain the CCXC rates, terms and conditions before BellSouth will permit the provisioning of CCXCs between the two collocated carriers. **Local Line is prohibited** from using the Collocation Space for the sole or primary purpose of cross-connecting to other collocated telecommunications carriers.

- 3.6.1 Local Line must contract with a BellSouth Certified Supplier to place the CCXC. The CCXC shall be provisioned using facilities owned by Local Line. Such cross-connections to other collocated telecommunications carriers may be made using either

electrical or optical facilities. Local Line shall be responsible for providing a letter of authorization (LOA), with the application, to BellSouth from the other collocated telecommunications carrier to which it will be cross-connecting. The Local Line-provisioned CCXC shall utilize BellSouth common cable support structure. There will be a recurring charge per linear foot, per cable, of common cable support structure used by Local Line to provision the CCXC to the other collocated telecommunications carrier. In those instances where Local Line's equipment and the equipment of the other collocated telecommunications carrier are located in contiguous caged Collocation Space, Local Line may use its own technicians to install co-carrier cross connects using either electrical or optical facilities between the equipment of both collocated telecommunications carriers by constructing a dedicated cable support structure between the two contiguous cages. Local Line shall deploy such electrical or optical cross-connections directly between its own facilities and the facilities of another collocated telecommunications carrier without being routed through BellSouth's equipment. Local Line shall not provision CCXC on any BellSouth distribution frame, POT (Point of Termination) Bay, DSX (Digital System Cross-Connect) or LGX (Light Guide Cross-Connect). Local Line is responsible for ensuring the integrity of the signal.

- 3.6.2 To place an order for CCXCs, Local Line must submit an Initial Application or Subsequent Application to BellSouth. If no modification to the Collocation Space is requested other than the placement of CCXCs, the Subsequent Application Fee for CCXCs, as defined in Exhibit B, will apply. If other modifications, in addition to the placement of CCXCs, are requested, either an Initial Application or Subsequent Application Fee will apply, pursuant to Section 6.3.1 of this Attachment. BellSouth will bill this nonrecurring fee on the date that it provides an Application Response to Local Line.

#### 4. **Occupancy**

- 4.1 **Occupancy.** BellSouth will notify Local Line in writing when the Collocation Space is ready for occupancy (Space Ready Date). Local Line will schedule and complete an acceptance walkthrough of the Collocation Space with BellSouth within fifteen (15) calendar days of the Space Ready Date. BellSouth will correct any deviations in Local Line's original or jointly amended application requirements within seven (7) calendar days after the walkthrough, unless the Parties mutually agree upon a different time frame. BellSouth will then establish a new Space Ready Date. Another acceptance walkthrough will be scheduled and conducted within fifteen (15) calendar days of the new Space Ready Date. This follow-up acceptance walkthrough will be limited to only those items identified in the initial walkthrough. If Local Line completes its acceptance walkthrough within the fifteen (15) calendar day interval, billing will begin upon the date of Local Line's acceptance of the Collocation Space (Space Acceptance Date). In the event Local Line fails to complete an acceptance walkthrough within this fifteen (15) calendar day interval, the Collocation Space shall be deemed accepted by Local Line on the Space Ready Date and billing will commence from that date. If Local Line decides to occupy the space prior to the

Space Ready Date, the date Local Line occupies the space is deemed the new Space Acceptance Date and billing will begin from that date. Local Line must notify BellSouth in writing that its collocation equipment installation is complete and operational with BellSouth's network. BellSouth may, at its discretion, refuse to accept any orders for cross-connects until it has received such notice. For the purposes of this paragraph, Local Line's telecommunications equipment will be deemed operational when it has been cross-connected to BellSouth's network for the purpose of provisioning telecommunication services to its customers.

4.2 Termination of Occupancy. In addition to any other provisions addressing termination of occupancy in this Agreement, Local Line may terminate its occupancy of a particular Collocation Space by submitting a Subsequent Application requesting termination of occupancy. Such termination shall be effective upon BellSouth's acceptance of the Space Relinquishment Form. Billing for monthly recurring charges will cease on the date that Local Line and BellSouth conduct an inspection of the terminated space and jointly sign off on the Space Relinquishment Form or on the date that Local Line signs off on the Space Relinquishment Form and sends this form to BellSouth, provided no discrepancies are found during BellSouth's subsequent inspection of the terminated space. If the subsequent inspection by BellSouth reveals discrepancies, billing will cease on the date that BellSouth and Local Line jointly conduct an inspection, confirming that Local Line has corrected all of the noted discrepancies identified by BellSouth. A Subsequent Application Fee will not apply for the termination of occupancy; however, specific disconnect fees may apply to certain rate elements in Florida. The particular disconnect fees that would apply in each state are contained in Exhibit B of this Attachment. BellSouth may terminate Local Line's right to occupy Collocation Space in the event Local Line fails to comply with any provision of this Agreement, including payment of the applicable fees contained in Exhibit B of this Attachment.

4.2.1 Upon termination of occupancy, Local Line, at its sole expense, shall remove its equipment and any other property owned, leased or controlled by the Local Line from the Collocation Space. Local Line shall have thirty (30) calendar days from the Bona Fide Firm Order (BFFO) date ("Termination Date") to complete such removal, including the removal of all equipment and facilities of Local Line's Guest(s), unless Local Line's Guest(s) has assumed responsibility for the Collocation Space housing the Guest(s)'s equipment and executed the appropriate documentation required by BellSouth prior to the Local Line removal date. Local Line shall continue the payment of all monthly recurring charges to BellSouth until the date Local Line, and if applicable Local Line's Guest(s), has fully vacated the Collocation Space and the Space Relinquishment Form has been accepted by BellSouth. If Local Line or Local Line's Guest(s) fails to vacate the Collocation Space within thirty (30) calendar days from the "Termination Date", BellSouth shall have the right to remove and dispose of the equipment and any other property of Local Line or Local Line's Guest(s), in any manner that BellSouth deems fit, at Local Line's expense and with no liability whatsoever for Local Line's property or Local Line's Guest(s)'s property. Upon termination of Local Line's right to occupy specific Collocation Space, the Collocation

Space will revert back to BellSouth's space inventory, and Local Line shall surrender the Collocation Space to BellSouth in the same condition as when it was first occupied by Local Line, with the exception of ordinary wear and tear, unless otherwise agreed to by the Parties. Local Line's BellSouth Certified Supplier shall be responsible for updating and making any necessary changes to BellSouth's records as required by BellSouth's Specifications including, but not limited to, BellSouth's Central Office Record Drawings and ERMA Records. Local Line shall be responsible for the cost of removing any Local Line constructed enclosure, together with any supporting structures (e.g., racking, conduits, or power cables), by the "Termination Date" and restoring the grounds to their original condition.

**5. Use of Collocation Space**

- 5.1 Equipment Type. BellSouth permits the collocation of any equipment necessary for interconnection to BellSouth's network or access to BellSouth's unbundled network elements in the provision of telecommunications services, as the term "necessary" is defined by FCC 47 C.F.R. Section 51.323 (b). The primary purpose and function of any equipment collocated in a "BellSouth Premises" must be for interconnection to BellSouth's network or access to BellSouth's unbundled network elements in the provision of telecommunications services.
- 5.1.1 Examples of equipment that would not be considered necessary include, but are not limited to: traditional circuit switching equipment, equipment used exclusively for call-related databases, computer servers used exclusively for providing information services, operations support system (OSS) equipment used to support collocated telecommunications carrier network operations, equipment that generates customer orders, manages trouble tickets or inventory, or stores customer records in centralized databases, etc. BellSouth will determine upon receipt of an application if the requested equipment is necessary based on the criteria established by the FCC. Multifunctional equipment placed on a "BellSouth Premises" must not place any greater relative burden on BellSouth's property than comparable single-function equipment. BellSouth reserves the right to permit collocation of any equipment on a nondiscriminatory basis.
- 5.1.2 Such equipment must, at a minimum, meet the following Telcordia Network Equipment Building Systems (NEBS) General Equipment Requirements: Criteria Level 1 requirements as outlined in Telcordia Special Report SR-3580, Issue 1. Except where otherwise required by a Commission, BellSouth shall comply with the applicable FCC rules relating to denial of collocation based on Local Line's failure to comply with this Section.
- 5.1.3 Local Line shall not request more DS0, DS1, DS3 and optical terminations for a collocation arrangement than the total port or termination capacity of the equipment physically installed in the arrangement. The total capacity of the equipment collocated in the arrangement will include equipment contained in an application, as well as

equipment already placed in the collocation arrangement. If full network termination capacity of the equipment being installed is not requested in the application, additional network terminations for the installed equipment will require the submission of another application. In the event Local Line submits an application for terminations that will exceed the total capacity of the collocated equipment, Local Line will be informed of the discrepancy by BellSouth and required to submit a revision to the application.

Commencing with the most current calendar quarter after the effective date of this Attachment, and thereafter with respect to each subsequent calendar quarter during the term of this Attachment, Local Line will, no later than thirty (30) days after the close of such calendar quarter, provide a report to ICS Collocation Product Management, Room 34A55, 675 W. Peachtree Street, Atlanta, Georgia 30375 listing any equipment in the Collocation Space (i) that was added during the calendar quarter to which such report pertains, and (ii) for which there is a UCC-1 lien holder or another entity that has a secured financial interest in such equipment. Equipment that satisfies both subparts (i) and (ii) of this section shall be defined as "Secured Equipment". If no Secured Equipment has been installed within a given calendar quarter, no report shall be due hereunder in connection with such calendar quarter.

- 5.2 Local Line shall not use the Collocation Space for marketing purposes, nor shall it place any identifying signs or markings outside the Collocation Space or on the grounds of the "BellSouth Premises".
- 5.3 Local Line shall place a plaque or affix other identification (e.g., stenciling) to Local Line's equipment, including the appropriate emergency contacts with their corresponding telephone numbers, in order for BellSouth to properly identify Local Line's equipment in the case of an emergency.
- 5.4 Entrance Facilities. Local Line may elect to place Local Line-owned or Local Line-leased fiber entrance facilities into its Collocation Space. BellSouth will designate the point of interconnection in close proximity to the "BellSouth Premises" building housing the Collocation Space, such as at an entrance manhole or a cable vault, which are physically accessible by both Parties. Local Line will provide and place fiber cable at the point of entrance of sufficient length to be pulled through conduit and into the splice location. Local Line will provide and install a sufficient length of fire retardant riser cable, to which the entrance cable will be spliced by BellSouth. The fire retardant riser cable will extend from the splice location to Local Line's equipment in the Collocation Space. In the event Local Line utilizes a non-metallic, riser-type entrance facility, a splice will not be required. Local Line must contact BellSouth for instructions prior to placing any entrance facility cable in the manhole. Local Line is responsible for the maintenance of the entrance facilities. At Local Line's option, BellSouth will accommodate, where technically feasible, a microwave entrance facility, pursuant to separately negotiated terms and conditions. In the case of adjacent collocation, copper facilities may be used between the adjacent collocation arrangement and the central office demarcation point unless BellSouth determines that limited space is available for the placement of entrance facilities.

- 5.5.1 Dual Entrance Facilities. BellSouth will provide at least two interconnection points at each Premise where at least two such interconnection points are available and capacity exists. Upon receipt of a request by Local Line for dual entrance facilities to its physical Collocation Space, BellSouth shall provide Local Line with information regarding BellSouth's capacity to accommodate the requested dual entrance facilities. If conduit in the serving manhole(s) is available and is not reserved for another purpose or for utilization within twelve (12) months of the receipt of an application for collocation, BellSouth will make the requested conduit space available for the installation of a second entrance facility to Local Line's Collocation Space. The location of the serving manhole(s) will be determined at the sole discretion of BellSouth. Where dual entrance facilities are not available due to lack of capacity, BellSouth will provide this information to Local Line in the Application Response.
- 5.5.2 Shared Use. Local Line may utilize spare capacity on an existing interconnector's entrance facility for the purpose of providing an entrance facility to Local Line's Collocation Space within the same "BellSouth Premises". BellSouth shall allow the splice, as long as the fiber is non-working fiber. Local Line must arrange with BellSouth in accordance with BellSouth's Special Construction Procedures, RL93-11-030BT, and provide a LOA from the other telecommunications carrier authorizing BellSouth to perform the splice of the Local Line-provided riser cable to the spare capacity on the entrance facility. If Local Line desires to allow another telecommunications carrier to use its entrance facilities, that other telecommunications carrier must arrange with BellSouth in accordance with BellSouth's Special Construction Procedures, RL93-11-030BT, and provide a LOA from Local Line authorizing BellSouth to perform the splice of that telecommunications carrier's provided riser cable to the spare capacity on Local Line's entrance facility.
- 5.6 Demarcation Point. BellSouth will designate the point(s) of demarcation between Local Line's equipment and/or network and BellSouth's network. Each Party will be responsible for the maintenance and operation of all equipment/facilities on its side of the demarcation point. For 2-wire and 4-wire connections to BellSouth's network, the demarcation point shall be a common block on BellSouth's designated conventional distributing frame (CDF). Local Line shall be responsible for providing the necessary cabling, and Local Line's BellSouth Certified Supplier shall be responsible for installing and properly labeling/stenciling the common block and any necessary cabling identified in Section 7 of this Attachment. Local Line or its agent must perform all required maintenance to the equipment/facilities on its side of the demarcation point, pursuant to Section 5.7, following, and may self-provision cross-connects that may be required within its own Collocation Space to activate service requests.
- 5.7 Local Line's Equipment and Facilities. Local Line, or if required by this Attachment, Local Line's BellSouth Certified Supplier, is solely responsible for the design, engineering, installation, testing, provisioning, performance, monitoring, maintenance and repair of the equipment and facilities used by Local Line which must be performed in compliance with all applicable BellSouth Specifications. Such equipment and

facilities may include, but are not limited to, cable(s), equipment, and point of termination connections. Local Line and its designated BellSouth Certified Supplier must follow and comply with all BellSouth Specifications outlined in the following BellSouth Technical Requirements: TR 73503, TR 73519, TR 73572, and TR 73564.

- 5.8 BellSouth's Access to Collocation Space. From time to time, BellSouth may require access to Local Line's Collocation Space. BellSouth retains the right to access Local Line's space for the purpose of making BellSouth equipment and building modifications (e.g., running, altering or removing racking, ducts, electrical wiring, HVAC, and cabling). BellSouth will give notice to Local Line at least forty-eight (48) hours before access to Local Line's Collocation Space is required. Local Line may elect to be present whenever BellSouth performs work in the Local Line's Collocation Space. The Parties agree that Local Line will not bear any of the expense associated with this type of work.
- 5.9 Access. Pursuant to Section 12, Local Line shall have access to its Collocation Space twenty-four (24) hours a day, seven (7) days a week. Local Line agrees to provide the name and social security number, date of birth, or driver's license number of each employee, supplier, or agent of Local Line or Local Line's Guest(s) that will be provided with access keys or cards (Access Keys), prior to the issuance of said Access Keys, using form RF-2906-C, the "CLEC and CLEC Certified Supplier Access Request and Acknowledgement" form. The appropriate key acknowledgement forms (the "Collocation Acknowledgement Sheet" for access cards and the "Key Acknowledgement Form" for keys) must be signed by Local Line and returned to BellSouth Access Management within fifteen (15) calendar days of Local Line's receipt. Failure to return these properly acknowledged forms will result in the holding of subsequent access key or card requests until the proper key acknowledgement documents have been received by BellSouth and reflect current information. Access Keys may not be duplicated under any circumstances. Local Line agrees to be responsible for all Access Keys and for the return of all Access Keys in the possession of Local Line's employees, suppliers, agents, or Guest(s) after termination of the employment relationship, the contractual obligation with Local Line ends, upon the termination of this Attachment, or upon the termination of occupancy of Collocation Space in a specific "BellSouth Premises".
- 5.9.1 BellSouth will permit one (1) accompanied site visit to Local Line's designated Collocation Space, after receipt of the BFFO, without charge to Local Line. Local Line must submit to BellSouth the completed Access Control Request Form for all employees or agents requiring access to a "BellSouth Premises" at least thirty (30) calendar days prior to the date Local Line desires access to the Collocation Space. In order to permit reasonable access during construction of the Collocation Space, Local Line may submit a request for its one (1) accompanied site visit to its designated Collocation Space at any time subsequent to BellSouth's receipt of the BFFO. In the event Local Line desires access to the Collocation Space after submitting such a request, but prior to the approval of its access request, in addition to the first accompanied free visit, BellSouth shall permit Local Line to access the Collocation



Space accompanied by a security escort, at Local Line's expense, which will be assessed pursuant to the Security Escort fees contained in Exhibit B. Local Line must request escorted access to its designated Collocation Space at least three (3) business days prior to the date such access is desired.

- 5.10 Lost or Stolen Access Devices. Local Line shall immediately notify BellSouth in writing when any of its Access Keys have been lost or stolen. If it becomes necessary for BellSouth to re-key buildings or deactivate an Access card as a result of a lost or stolen Access Device(s) or for failure of Local Line's employees, suppliers, agents or Guest(s) to return an Access Device(s), Local Line shall pay for the costs of re-keying or deactivating the Access card pursuant to the fees set forth in Exhibit B.
- 5.11 Interference or Impairment. Notwithstanding any other provisions of this Attachment, Local Line shall not use any product or service provided under this Agreement, any other service related thereto or used in combination therewith, or place or use any equipment or facilities in any manner that 1) significantly degrades, interferes with or impairs service provided by BellSouth or any other entity or any person's use of its telecommunications services; 2) endangers or damages the equipment, facilities or any other property of BellSouth or any other entity or person; 3) compromises the privacy of any communications; or 4) creates an unreasonable risk of injury or death to any individual or to the public. If BellSouth reasonably determines that any equipment or facilities of Local Line violates the provisions of this paragraph, BellSouth shall provide written notice to Local Line, which shall direct Local Line to cure the violation within forty-eight (48) hours of Local Line's receipt of written notice or, at a minimum, to commence curative measures within twenty-four (24) hours and exercise reasonable diligence to complete such measures as soon as possible thereafter. After receipt of the notice, the Parties agree to consult immediately and, if necessary, to conduct an inspection of the Collocation Space.
- 5.11.1 Except in the case of the deployment of an advanced service which significantly degrades the performance of other advanced services or traditional voice band services, if Local Line fails to take curative action within forty-eight (48) hours or if the violation is of a character that poses an immediate and substantial threat of damage to property or injury or death to any person, or any other significant degradation, interference or impairment of BellSouth's or another entity's service, then and only in that event, BellSouth may take such action as it deems appropriate to correct the violation including, without limitation, the interruption of electrical power to Local Line's equipment and/or facilities. BellSouth will endeavor, but is not required, to provide notice to Local Line prior to the taking of such action and BellSouth shall have no liability to Local Line for any damages arising from such action, except to the extent that such action by BellSouth constitutes willful misconduct.
- 5.11.2 For purposes of this Section, the term "significantly degrades" shall be defined as an action that noticeably impairs a service from a user's perspective. In the case of the deployment of an advanced service which significantly degrades the performance of other advanced services or traditional voice band services and Local Line fails to take

curative action within forty-eight (48) hours of Local Line's receipt of written notice, BellSouth will establish before the appropriate Commission that the technology deployment is causing the significant degradation. Any claims of network harm presented to Local Line or, if subsequently necessary, the Commission must be provided by BellSouth with specific and verifiable information. When BellSouth demonstrates that a certain technology deployed by Local Line is significantly degrading the performance of other advanced services or traditional voice band services, Local Line shall discontinue deployment of that technology and migrate its customers to other technologies that will not significantly degrade the performance of such services. Where the only degraded service itself is a known disturber, and the newly deployed technology satisfies at least one of the criteria for a presumption that it is acceptable for deployment under Section 47 C.F.R. 51.230, the degraded service shall not prevail against the newly-deployed technology.

- 5.12 Personalty and its Removal. Facilities and equipment placed by Local Line in the Collocation Space shall not become a part of the Collocation Space, even if nailed, screwed or otherwise fastened to the Collocation Space, but shall retain their status as personal property and may be removed by Local Line at any time. Any damage caused to the Collocation Space by Local Line's employees, suppliers, agents or representatives during the installation or removal of such property shall be promptly repaired by Local Line at its sole expense. If Local Line decides to remove equipment from its Collocation Space and the removal requires no physical work be performed by BellSouth and Local Line's physical work includes, but is not limited to, power reduction, cross-connects, or tie pairs, BellSouth will bill Local Line an Administrative Only Application Fee as set forth in Exhibit B. This non-recurring fee will be billed on the date that BellSouth provides an Application Response to Local Line.
- 5.13 Alterations. Under no condition shall Local Line or any person acting on behalf of Local Line make any rearrangement, modification, augment, improvement, addition, and/or other alteration which could affect in any way space, power, HVAC, and/or safety considerations to the Collocation Space or the "BellSouth Premises", without the express written consent of BellSouth, which shall not be unreasonably withheld. The cost of any such rearrangement, modification, augment, improvement, addition, and/or other alteration shall be paid by Local Line, and shall require a Subsequent Application and will result in the assessment of either a Subsequent Application Fee, an Administrative Only Application Fee or an Initial Application Fee as set forth in Section 6.3.1, which will be billed by BellSouth on the date that BellSouth provides Local Line with an Application Response.
- 5.14 Janitorial Service. Local Line shall be responsible for the general upkeep of its Collocation Space. Local Line shall arrange directly with a BellSouth Certified Supplier for janitorial services applicable to Caged Collocation Space. BellSouth shall provide a list of such suppliers on a "BellSouth Premises"-specific basis, upon request.

**6. Ordering and Preparation of Collocation Space**

- 6.1 If any state or federal regulatory agency imposes procedures or intervals applicable to Local Line and BellSouth that are different from the procedures or intervals set forth in this Section, whether now in effect or that become effective after execution of this Agreement, those procedures or intervals shall supersede the requirements set forth herein for that jurisdiction for all applications that are submitted for the first time after the effective date thereof.
- 6.2 Initial Application. For Local Line's or Local Line's Guest's(s') initial equipment placement, Local Line shall input a Physical Expanded Interconnection Application Document (Initial Application) directly into BellSouth's electronic application (e.App) system for processing. The Initial Application is considered Bona Fide when it is complete and accurate, meaning that all of the required fields on the application are completed with the appropriate type of information. An application fee will apply to each application submitted by Local Line and will be billed by BellSouth on the date BellSouth provides Local Line with an Application Response.
- 6.3 Subsequent Application. In the event Local Line or Local Line's Guest(s) desires to modify its use of the Collocation Space after a BFFO, Local Line shall complete an application (Subsequent Application) that contains all of the detailed information associated with the alteration related to the Collocation Space, as defined in Section 5.13 of this Attachment. The Subsequent Application will be considered Bona Fide when it is complete and accurate, meaning that all of the required fields on the Subsequent Application are completed with the appropriate type of information associated with the alteration. BellSouth shall determine what modifications, if any, to the "BellSouth Premises" are required to accommodate the change requested by Local Line in the application. Such modifications to the "BellSouth Premises" may include, but are not limited to, floor loading changes, changes necessary to meet HVAC requirements, changes to power plant requirements, equipment additions, etc.
- 6.3.1 Subsequent Application Fee. The application fee paid by Local Line shall be dependent upon the level of assessment needed. If the modifications reflected on the Subsequent Application require no labor or capital expenditure by BellSouth, but BellSouth must perform an assessment of the application to evaluate whether or not BellSouth would be required to perform necessary infrastructure or provisioning activities, then an Administrative Only Application Fee shall apply. This Administrative Only Application Fee would be applicable in instances such as those associated with a Transfer of Ownership of the Collocation Space, Removal of Equipment from the Collocation Space, a modification to an application prior to receipt of the BFFO and a V-to-P Conversion (In Place). The fee for a Subsequent Application in which the modifications requested have limited effect (e.g., requires labor expenditure but no capital expenditure by BellSouth and where sufficient cable support structure, HVAC, power and terminations are available) shall be the Subsequent Application Fee, as set forth in Exhibit B. A modification involving a capital expenditure by BellSouth shall require Local Line to submit the Subsequent

Application with an Initial Application Fee. The appropriate nonrecurring application fee will be billed on the date BellSouth provides Local Line with an Application Response.

- 6.4 Space Preferences. If Local Line has previously requested and received a Space Availability Report for the “BellSouth Premises”, Local Line may submit up to three (3) space preferences on its application by identifying the specific space identification numbers referenced on the Space Availability Report for the space it is requesting. In the event BellSouth cannot accommodate the Local Line's preference(s), Local Line may accept the space allocated by BellSouth or cancel its application and submit another application requesting additional space preferences for the same central office. This application will be treated as a new application and an application fee will apply. The application fee will be billed by BellSouth on the date that BellSouth provides Local Line with an Application Response.
- 6.5 Space Availability Notification.
- 6.5.1 Unless otherwise specified, BellSouth will respond to an application within ten (10) calendar days as to whether space is available or not available within the requested “BellSouth Premises”. BellSouth will also respond as to whether the application is Bona Fide and if it is not Bona Fide, the items/revisions necessary to cause the application to become Bona Fide. If the amount of space requested is not available, BellSouth will notify Local Line of the amount of space that is available and no application fee will apply. When BellSouth's response includes an amount of space less than that requested by Local Line or space that is configured differently, no application fee will apply. If Local Line decides to accept the available space, Local Line must resubmit its application to reflect the actual space available, including the configuration of the space, prior to submitting a BFFO. When Local Line resubmits its application to accept the available space, BellSouth will bill Local Line the appropriate application fee.
- 6.5.2 BellSouth will respond to a Florida application within fifteen (15) calendar days as to whether space is available or not available within a “BellSouth Premises”. BellSouth will also respond as to whether the application is Bona Fide and if it is not Bona Fide, the items/revisions necessary to cause the application to become Bona Fide. If a lesser amount of space than requested is available, BellSouth will provide an Application Response for the amount of space that is available and bill Local Line an appropriate application fee on the date that BellSouth provides the Application Response. When BellSouth's Application Response includes an amount of space less than that requested by Local Line or space that is configured differently, if Local Line decides to accept the available space, Local Line must amend its application to reflect the actual space available, including the configuration of the space, prior to submitting a BFFO.
- 6.5.3 Denial of Application. If BellSouth notifies Local Line that no space is available (Denial of Application), BellSouth will not assess an application fee to Local Line.

After notifying Local Line that there is no available space in the requested "BellSouth Premises", BellSouth will allow Local Line, upon request, to tour the entire "BellSouth Premises" within ten (10) calendar days of such Denial of Application. In order to schedule this tour within ten (10) calendar days, BellSouth must receive the request for a tour of the "BellSouth Premises" within five (5) calendar days of the Denial of Application.

- 6.6 Filing of Petition for Waiver. Upon Denial of Application, BellSouth will timely file a petition with the appropriate Commission pursuant to 47 U.S.C. § 251(c)(6). BellSouth shall provide to the Commission any information requested by that Commission. Such information shall include which space, if any, BellSouth or any of BellSouth's affiliates have reserved for future use and a detailed description of the specific future uses for which the space has been reserved. Subject to an appropriate nondisclosure agreement or provision, BellSouth shall permit Local Line to inspect any floor plans or diagrams that BellSouth provides to the Commission.
- 6.7 Waiting List. On a first-come, first-served basis, which is governed by the date of receipt of an application or Letter of Intent, BellSouth will maintain a waiting list of requesting telecommunication carriers that have either received a Denial of Application or, where it is publicly known that the "BellSouth Premises" is out of space, have submitted a Letter of Intent to collocate in that "BellSouth Premises". BellSouth will notify each telecommunication carrier on the waiting list that can be accommodated by the amount of space that becomes available, according to the position of the telecommunication carrier on said waiting list.
- 6.7.1 In Florida, on a first-come, first-served basis, which is governed by the date of receipt of an application or Letter of Intent, BellSouth will maintain a waiting list of requesting telecommunication carriers that have either received a Denial of Application or, where it is publicly known that the "BellSouth Premises" is out of space, have submitted a Letter of Intent to collocate in that "BellSouth Premises". Sixty (60) calendar days prior to space becoming available, if known, BellSouth will notify the Commission and the telecommunication carriers on the waiting list by mail when space becomes available according to the position of each telecommunication carrier on said waiting list. If BellSouth does not know sixty (60) calendar days in advance of when space will become available, BellSouth will notify the Commission and the telecommunication carriers on the waiting list within two (2) business days of the determination that space will become available. A telecommunication carrier that, upon denial of physical Collocation Space, requests virtual Collocation Space shall automatically be placed on the waiting list for physical Collocation Space that may become available in the future.
- 6.7.2 When physical Collocation Space becomes available, Local Line must submit an updated, complete, and accurate application to BellSouth within thirty (30) calendar days of notification by BellSouth that physical Collocation Space will be available in the requested "BellSouth Premises" previously out of space. If Local Line has originally requested caged Collocation Space and cageless Collocation Space becomes

available, Local Line may refuse such space and notify BellSouth in writing within the thirty (30) day timeframe that Local Line wants to maintain its place on the waiting list for caged Physical Collocation Space, without accepting the available cageless Collocation Space.

Local Line may accept an amount of space less than what it originally requested by submitting an application as set forth above, and upon request, may maintain its position on the waiting list for the remaining space that was initially requested. If Local Line does not submit an application or notify BellSouth in writing as described above, BellSouth will offer the space to the next telecommunication carrier on the waiting list and remove Local Line from the waiting list. Upon request, BellSouth will advise Local Line as to its position on the waiting list.

6.8 Public Notification. BellSouth will maintain on its Interconnection Services website a notification document that will indicate all "BellSouth Premises" that are without available space. BellSouth shall update such document within ten (10) calendar days of the date that BellSouth becomes aware that insufficient space is available to accommodate physical collocation. BellSouth will also post a document on its Interconnection Services website that contains a general notice when space becomes available in a "BellSouth Premises" previously on the space exhaust list.

6.9 Application Response.

6.9.1 In Florida, within fifteen (15) calendar days of receipt of a Bona Fide Application, when space has been determined to be available or when a lesser amount of space than that requested is available, then with respect to the space available, BellSouth will provide an Application Response including sufficient information to enable Local Line to place a firm order. The Application Response will include, at a minimum, the configuration of the space, the Cable Installation Fee, Cable Records Fee, and the space preparation fees, as described in Section 8. When Local Line submits ten (10) or more applications within ten (10) calendar days, the initial fifteen (15) calendar day response interval will increase by ten (10) calendar days for every additional ten (10) applications or fraction thereof.

6.10 Application Modifications.

6.10.1 If a modification or revision is made to any information in the Bona Fide Application prior to a BFFO, with the exception of modifications to Customer Information, Contact Information or Billing Contact Information, at the request of Local Line, or as necessitated by technical considerations, the application shall be considered a new application and handled as a new application with respect to the response and provisioning intervals. BellSouth will charge Local Line the appropriate application fee associated with the level of assessment performed by BellSouth. **If the modification requires no labor or capital expenditure by BellSouth, but BellSouth must perform an assessment of the application to evaluate whether or not BellSouth would be required to perform necessary infrastructure or provisioning activities, then an**

Administrative Only Application Fee shall apply. The fee for an application modification in which the modification requested has limited effect (e.g., requires labor expenditure but no capital expenditure by BellSouth and where sufficient cable support structure, HVAC, power and terminations are available) shall be the Subsequent Application Fee as set forth in Exhibit B. A modification involving a capital expenditure by BellSouth shall require Local Line to submit the application with an Initial Application Fee. The appropriate nonrecurring application fee will be billed on the date BellSouth provides Local Line with an Application Response.

6.11 **Bona Fide Firm Order.**

6.11.1 Local Line shall indicate its intent to proceed with equipment installation in a "BellSouth Premises" by submitting a Bona Fide Firm Order (BFFO) to BellSouth. The BFFO must be received by BellSouth no later than thirty (30) calendar days after BellSouth's Application Response to Local Line's Bona Fide Application or Local Line's application will expire.

6.11.2 BellSouth will establish a firm order date based upon the date BellSouth is in receipt of Local Line's BFFO. BellSouth will acknowledge the receipt of Local Line's BFFO within seven (7) calendar days of receipt, so that Local Line will have positive confirmation from BellSouth that its BFFO has been received. BellSouth's response to a BFFO will include a Firm Order Confirmation, which contains the firm order date. No revisions can be made to a BFFO.

7. **Construction and Provisioning**

7.1 **Construction and Provisioning Intervals.**

7.1.1 In Florida, BellSouth will complete construction of physical Collocation Space as soon as possible within a maximum of ninety (90) calendar days from receipt of a BFFO or as agreed to by the Parties. For virtual Collocation Space, BellSouth will complete construction as soon as possible within a maximum of sixty (60) calendar days from receipt of a BFFO or as agreed to by the Parties. For Augments requested to Collocation Space after the initial space has been completed, BellSouth will complete construction for Collocation Space as soon as possible within a maximum of forty-five (45) calendar days from receipt of a BFFO or as agreed to by the Parties. If BellSouth does not believe that construction will be completed within the relevant provisioning interval and BellSouth and Local Line cannot agree upon a completion date, within forty-five (45) calendar days of receipt of the BFFO for an initial request, or within thirty (30) calendar days of receipt of the BFFO for an Augment, BellSouth may seek an extension from the Commission.

7.1.2 When Local Line adds equipment within initial demand parameters that requires no additional space preparation work on the part of BellSouth, then no additional charges or intervals will be imposed by BellSouth that would cause delay in Local Line's operation.

Version 3Q03: 11/12/2003

- 7.2 Joint Planning. Joint planning between BellSouth and Local Line will commence within a maximum of twenty (20) calendar days from BellSouth's receipt of a BFFO. BellSouth will provide the preliminary design of the Collocation Space and the equipment configuration requirements as reflected in the Bona Fide Application and BFFO. The Collocation Space completion interval will be provided to Local Line during the joint planning meeting.
- 7.3 Permits. Each Party, its agent(s) or BellSouth Certified Supplier(s) will file for the appropriate permits required for the scope of work to be performed by that Party, its agent(s) or BellSouth Certified Supplier(s) within ten (10) calendar days of the completion of the finalized construction design and specifications.
- 7.4 Acceptance Walkthrough. Local Line will schedule and complete an acceptance walkthrough of the Collocation Space with BellSouth within fifteen (15) calendar days after the Space Ready Date. In the event Local Line fails to complete an acceptance walkthrough within this fifteen (15) day interval, the Collocation Space shall be deemed accepted by Local Line on the Space Ready Date. BellSouth will correct any deviations to Local Line's original or jointly amended design and/or specification requirements within seven (7) calendar days after the walkthrough, unless the Parties mutually agree upon a different timeframe.
- 7.5 Circuit Facility Assignments (CFAs). Unless otherwise specified, BellSouth will provide CFAs to Local Line prior to the applicable provisioning interval set forth herein (Provisioning Interval) for those "BellSouth Premises" in which Local Line has physical Collocation Space with no POT bay or with a grand fathered POT bay provided by BellSouth. BellSouth cannot provide CFAs to Local Line prior to the Provisioning Interval for those "BellSouth Premises" in which Local Line has physical Collocation Space with a POT bay provided by Local Line or virtual Collocation Space, until Local Line provides BellSouth with the following information:
- For physical Collocation Space with a Local Line-provided POT bay, Local Line shall provide BellSouth with a complete layout of the POT panels on an equipment inventory update (EIU) form, showing locations, speeds, etc.
- For virtual Collocation Space, Local Line shall provide BellSouth with a complete layout of Local Line's equipment on an equipment inventory update (EIU) form, including the locations of the low speed ports and the specific frame terminations to which the equipment will be wired by Local Line's BellSouth Certified Supplier.
- 7.5.1 BellSouth cannot begin work on the CFAs until the complete and accurate EIU form is received from Local Line. If the EIU form is provided within ten (10) calendar days prior to the ending date of the Provisioning Interval, then the CFAs will be made available by the ending date of the Provisioning Interval. If the EIU form is not received ten (10) calendar days prior to the ending date of the Provisioning Interval, then the CFAs will be provided within ten (10) calendar days of receipt of the EIU form.



- 7.5.2 BellSouth will bill Local Line a nonrecurring charge, as set forth in Exhibit B, each time Local Line requests a resend of its CFAs for any reason other than a BellSouth error in the CFAs initially provided to Local Line.
- 7.6 Use of BellSouth Certified Supplier. Local Line shall select a supplier which has been approved as a BellSouth Certified Supplier to perform all engineering and installation work. Local Line and Local Line's BellSouth Certified Supplier must follow and comply with all of BellSouth's Specifications, as outlined in the following BellSouth Technical Requirements: TR 73503, TR 73519, TR 73572, and TR 73564. In some cases, Local Line must select different BellSouth Certified Suppliers for those work activities associated with transmission equipment, switching equipment and power equipment. BellSouth shall provide Local Line with a list of BellSouth Certified Suppliers upon request. The BellSouth Certified Supplier(s) shall be responsible for installing Local Line's equipment and associated components, extending power cabling to the BellSouth power distribution frame, performing operational tests after installation is completed, and notifying BellSouth's equipment engineers and Local Line upon successful completion of the installation, etc. The BellSouth Certified Supplier shall bill Local Line directly for all work performed for Local Line pursuant to this Attachment. BellSouth shall have no liability for, nor responsibility to pay, such charges imposed by Local Line's BellSouth Certified Supplier. BellSouth shall make available its supplier certification program to Local Line or any supplier proposed by Local Line and will not unreasonably withhold certification. All work performed by or for Local Line shall conform to generally accepted industry standards.
- 7.7 Alarm and Monitoring. BellSouth shall place environmental alarms in the "BellSouth Premises" for the protection of BellSouth equipment and facilities. Local Line shall be responsible for the placement, monitoring and removal of environmental and equipment alarms used to service Local Line's Collocation Space. Upon request, BellSouth will provide Local Line with an applicable tariffed service(s) to facilitate remote monitoring of collocated equipment by Local Line. Both Parties shall use best efforts to notify the other of any verified environmental condition known to that Party.
- 7.8 Virtual to Physical Collocation Relocation. In the event physical Collocation Space was previously denied at a "BellSouth Premises" due to technical reasons or space limitations and physical Collocation Space has subsequently become available, Local Line may relocate its existing virtual collocation arrangement(s) to a physical collocation arrangement(s) and pay the appropriate fees associated with physical Collocation Space and the rearrangement or reconfiguration of services currently being terminated in the virtual collocation arrangement. If BellSouth knows when additional space for physical collocation may become available at the "BellSouth Premises" requested by Local Line, such information will be provided to Local Line in BellSouth's written denial of physical Collocation Space. To the extent that (i) physical Collocation Space becomes available to Local Line within one hundred eighty (180) calendar days of BellSouth's written denial of Local Line's request for physical Collocation Space, (ii) BellSouth had knowledge that the space was going to become available, and (iii) Local Line was not informed in the written denial that physical

Collocation Space would become available within such one hundred eighty (180) calendar day period, then Local Line may relocate its virtual collocation arrangement to a physical collocation arrangement and will receive a credit for any nonrecurring charges previously paid for such virtual Collocation Space. Local Line must arrange with a BellSouth Certified Supplier for the relocation of equipment from its virtual Collocation Space to its physical Collocation Space and will bear the cost of such relocation.

- 7.9 Virtual to Physical Conversion (In-Place). Virtual collocation arrangements may be converted to “in-place” physical collocation arrangements if the potential conversion meets all of the following criteria: 1) there is no change in the amount of equipment or the configuration of the equipment that was in the virtual Collocation Space; 2) the conversion of the virtual collocation arrangement will not cause the equipment or the results of that conversion to be located in a space that BellSouth has reserved for its own future needs; 3) the converted arrangement does not limit BellSouth’s ability to secure its own equipment and facilities due to the location of the virtual Collocation Space; and 4) any changes to the arrangement can be accommodated by existing power, HVAC, and other requirements. Unless otherwise specified, BellSouth will complete virtual to physical conversions (in-place) within sixty (60) calendar days from receipt of the BFFO. BellSouth will bill Local Line an Administrative Only Application Fee, as set forth in Exhibit B, on the date BellSouth provides an Application Response to Local Line.
- 7.10 Cancellation. If at any time prior to space acceptance, Local Line cancels its order for Collocation Space (Cancellation), BellSouth will bill the applicable nonrecurring charge(s) for any and all work processes for which work has begun or been completed.
- 7.11 Licenses. Local Line, at its own expense, will be solely responsible for obtaining from the proper governmental authorities, and any other appropriate agency, entity, or person, all rights, privileges, permits, licenses, and certificates necessary or required to operate as a provider of telecommunication services to the public or to build-out, equip and/or occupy Collocation Space in a “BellSouth Premises”.
- 7.12 Environmental Compliance. The Parties agree to utilize and adhere to the Environmental Hazard Guidelines identified in Exhibit A attached hereto.
- 8. Rates and Charges**
- 8.1 Application Fee. BellSouth shall assess a nonrecurring application fee via a service order on the date BellSouth responds pursuant to Section 6.10 (Application Response).
- 8.2 Cable Installation. Cable Installation Fee(s) are assessed per entrance cable placed. This nonrecurring fee will be billed by BellSouth upon receipt of Local Line’s BFFO.

- 8.3 Recurring Charges. If Local Line has met the applicable fifteen (15) calendar day walkthrough interval specified in Section 4, billing for recurring charges will begin upon the Space Acceptance Date. In the event that Local Line fails to complete an acceptance walkthrough within the applicable fifteen (15) calendar day interval, billing for recurring charges will commence on the Space Ready Date. If Local Line occupies the space prior to the Space Ready Date, the date Local Line occupies the space is deemed the new Space Acceptance Date and billing for recurring charges will begin on that date.
- 8.4 Space Preparation. Space preparation fees consist of a nonrecurring charge for Firm Order Processing and monthly recurring charges for Central Office Modifications assessed per arrangement, per square foot and Common Systems Modifications assessed per arrangement, per square foot for cageless collocation and per cage for caged collocation. Local Line shall remit payment of the nonrecurring Firm Order Processing fee coincident with the submission of a BFFO. These charges recover the costs associated with preparing the Collocation Space, which includes, but is not limited to, the following items: a survey, engineering of the Collocation Space, design and modification costs for network, building and support systems, etc. In the event Local Line opts for cageless space, the space preparation fees will be assessed based on the total square footage of floor space dedicated to Local Line as prescribed in this Section.
- 8.5 Floor Space. The Floor Space Charge includes reasonable charges for lighting, HVAC, and other allocated expenses associated with maintenance of the “BellSouth Premises”, but does not include any power-related costs incurred by BellSouth. When the Collocation Space is enclosed, Local Line shall pay floor space charges based upon the number of square feet so enclosed. The minimum size for caged Collocation Space is 100 square feet. Additional caged Collocation Space may be requested in increments of 50 square feet. When the Collocation Space is not enclosed, Local Line shall pay floor space charges based upon the following floor space calculation:  $[(\text{depth of the equipment lineup in which the rack is placed}) + (0.5 \times \text{maintenance aisle depth}) + (0.5 \times \text{wiring aisle depth})] \times (\text{width of rack and spacers})$ . For purposes of this calculation, the depth of the equipment lineup shall consider the footprint of equipment racks plus any equipment overhang. BellSouth will assign unenclosed Collocation Space in conventional equipment rack lineups where feasible. In the event Local Line’s collocated equipment requires special cable racking, isolated grounding or other treatment which prevents placement within conventional equipment rack lineups, Local Line shall be required to request an amount of floor space sufficient to accommodate the total equipment arrangement.
- 8.6 Power. BellSouth shall make available -48 Volt (-48V) Direct Current (DC) power for Local Line’s Collocation Space at a BellSouth Power Board or BellSouth Battery Distribution Fuse Bay (BDFB) upon Local Line’s request within the “BellSouth Premises”; however, the determination of whether BellSouth will permit the power configuration requested by Local Line will be made at BellSouth’s sole discretion, which shall not be unreasonably withheld. BellSouth will revise Local Line’s recurring

power charges to reflect a power upgrade upon notification of the completion of the upgrade by Local Line's BellSouth Certified Vendor. BellSouth will revise recurring power charges to reflect a power reduction upon BellSouth's receipt of the Power Reduction Form from Local Line certifying the completion of the power reduction work, including the removal of the power cabling by Local Line's BellSouth Certified Supplier.

- 8.6.1 When obtaining power from a BDFB, fuses and power cables (A&B) must be engineered (sized), and installed by Local Line's BellSouth Certified Supplier. Likewise, when obtaining power from a BellSouth power board, power cables (A&B) must be engineered (sized) and installed by Local Line's BellSouth Certified Supplier. Local Line is responsible for contracting with a BellSouth Certified Supplier for the power distribution feeder cable running from a BellSouth BDFB or BellSouth power board to Local Line's equipment. The determination of whether Local Line's requested DC power will be provided from the BellSouth BDFB or BellSouth power board will be made at BellSouth's sole, but reasonable, discretion. The BellSouth Certified Supplier contracted by Local Line must provide BellSouth with a copy of the engineering power specifications prior to the day on which Local Line's equipment becomes operational (Commencement Date). BellSouth will provide the common power feeder cable support structure between the BellSouth BDFB or BellSouth power board and Local Line's Collocation Space. Local Line shall contract with a BellSouth Certified Supplier who will be responsible for the following power provisioning activities: installing, removing or replacing dedicated power cable support structure within Local Line's arrangement, power cable feeds, and terminations of cable. A BellSouth Certified Supplier must perform all terminations at a BellSouth power board. Local Line shall comply with all applicable National Electric Code (NEC), BellSouth TR73503, Telcordia and ANSI Standards regarding power cabling, installation, and maintenance.
- 8.6.2 If Local Line elects to install its own DC Power Plant, BellSouth shall provide Alternating Current (AC) power to feed Local Line's DC Power Plant. Charges for AC power will be assessed per breaker ampere per month. Rates include the provision of commercial and standby AC power. When obtaining power from a BellSouth service panel, protection devices and power cables must be engineered (sized) and installed by Local Line's BellSouth Certified Supplier, except that BellSouth shall engineer and install protection devices and power cables for Adjacent Collocation. Local Line's BellSouth Certified Supplier must also provide a copy of the engineering power Specifications prior to the Commencement Date. Charges for AC power shall be assessed pursuant to the rates specified in Exhibit B. AC power voltage and phase ratings shall be determined on a per location basis. At Local Line's option, Local Line may arrange for AC power in an adjacent collocation arrangement from a retail provider of electrical power.
- 8.6.3 If Local Line desire to reduce the amount of power that it has requested from BellSouth, Local Line must submit a Subsequent Application for this power reduction. If no other modifications to the Collocation Space are requested other than the

reduction in power, the Power Reduction Only, Application fee, as set forth in Exhibit B, will apply. If other modifications are requested in addition to the reduction of power, the Subsequent Application Fee will apply. BellSouth will bill the appropriate nonrecurring application fee on the date BellSouth provides an Application Response to Local Line.

- 8.7 Security Escort. A security escort will be required whenever Local Line or its approved agent desires access to the entrance manhole or must have access to a "BellSouth Premises" after the one (1) accompanied site visit allowed pursuant to Section 5.9 prior to completing BellSouth's Security Training requirements. The rates for security escort service are assessed, beginning with the scheduled escort time, pursuant to the fee schedule in Exhibit B. BellSouth will wait for one-half (1/2) hour after the scheduled time for such an escort and Local Line shall pay for such half-hour charges in the event Local Line fails to show up.
- 8.8 Cable Record charges. These charges apply for work required to add or change existing cable records assigned to Local Line in BellSouth's database systems. The VG/DS0 per cable record charge is for a maximum of 3600 records. The Fiber cable record charge is for a maximum of 99 records. The Cable Record charges are assessed as nonrecurring fees in all Florida, and will be billed upon receipt of Local Line's BFFO.
- 8.9 Other. If no rate is identified in the contract, the rate for the specific service or function will be negotiated by the Parties upon request by either Party.

## 9. Insurance

- 9.1 Local Line shall, at its sole cost and expense, procure, maintain, and keep in force insurance as specified in this Section and underwritten by insurance companies licensed to do business in the states applicable under this Agreement and having a Best's Insurance Rating of A-.
- 9.2 Local Line shall maintain the following specific coverage:
- 9.2.1 Commercial General Liability coverage in the amount of ten million dollars (\$10,000,000.00) or a combination of Commercial General Liability and Excess/Umbrella coverage totaling not less than ten million dollars (\$10,000,000.00). BellSouth shall be named as an Additional Insured on the Commercial General Liability policy as specified herein.
- 9.2.2 Statutory Workers Compensation coverage and Employers Liability coverage in the amount of one hundred thousand dollars (\$100,000.00) each accident, one hundred thousand dollars (\$100,000.00) each employee by disease, and five hundred thousand dollars (\$500,000.00) policy limit by disease.

- 9.2.3 All Risk Property coverage on a full replacement cost basis insuring all of Local Line's real and personal property situated on or within BellSouth's Central Office location(s).
- 9.2.4 Local Line may elect to purchase business interruption and contingent business interruption insurance, having been advised that BellSouth assumes no liability for loss of profit or revenues should an interruption of service occur.
- 9.3 The limits set forth in Section 9.2 above may be increased by BellSouth from time to time during the term of this Agreement upon thirty (30) calendar days notice to Local Line to at least such minimum limits as shall then be customary with respect to comparable occupancy of BellSouth structures.
- 9.4 All policies purchased by Local Line shall be deemed to be primary and not contributing to or in excess of any similar coverage purchased by BellSouth. All insurance must be in effect on or before the date equipment is delivered to BellSouth's Premises and shall remain in effect for the term of this Attachment or until all Local Line's property has been removed from BellSouth's Premises, whichever period is longer. If Local Line fails to maintain required coverage, BellSouth may pay the premiums thereon and seek reimbursement of same from Local Line.
- 9.5 Local Line shall submit certificates of insurance reflecting the coverage required pursuant to this Section a minimum of ten (10) business days prior to the commencement of any work in the Collocation Space. Failure to meet this interval may result in construction and equipment installation delays. Local Line shall arrange for BellSouth to receive thirty (30) business days' advance notice of cancellation from Local Line's insurance company. Local Line shall forward a certificate of insurance and notice of cancellation/non-renewal to BellSouth at the following address:
- BellSouth Telecommunications, Inc.  
Attn.: Risk Management Coordinator  
17H53 BellSouth Center  
675 W. Peachtree Street  
Atlanta, Georgia 30375
- 9.6 Local Line must conform to recommendations made by BellSouth's fire insurance company to the extent BellSouth has agreed to, or shall hereafter agree to, such recommendations.
- 9.7 Self-Insurance. If Local Line's net worth exceeds five hundred million dollars (\$500,000,000), Local Line may elect to request self-insurance status in lieu of obtaining any of the insurance required in Sections 9.2.1 and 9.2.2. Local Line shall provide audited financial statements to BellSouth thirty (30) calendar days prior to the commencement of any work in the Collocation Space. BellSouth shall then review such audited financial statements and respond in writing to Local Line in the event that self-insurance status is not granted to Local Line. If BellSouth approves Local Line for self-insurance, Local Line shall annually furnish to BellSouth, and keep current, evidence of such net worth that is attested to by one of Local Line's corporate

officers. The ability to self-insure shall continue so long as the Local Line meets all of the requirements of this Section. If Local Line subsequently no longer satisfies this Section, Local Line is required to purchase insurance as indicated by Sections 9.2.1 and 9.2.2.

- 9.8 The net worth requirements set forth in Section 9.7 may be increased by BellSouth from time to time during the term of this Attachment upon thirty (30) calendar days' notice to Local Line to at least such minimum limits as shall then be customary with respect to comparable occupancy of BellSouth structures.
- 9.9 Failure to comply with the provisions of this Section will be deemed a material breach of this Attachment.

## **10. Mechanics Liens**

- 10.1 If any mechanics lien or other liens shall be filed against property of either Party (BellSouth or Local Line), or any improvement thereon by reason of or arising out of any labor or materials furnished or alleged to have been furnished or to be furnished to or for the other Party or by reason of any changes, or additions to said property made at the request or under the direction of the other Party, the other Party directing or requesting those changes shall, within thirty (30) business days after receipt of written notice from the Party against whose property said lien has been filed, either pay such lien or cause the same to be bonded off the affected property in the manner provided by law. The Party causing said lien to be placed against the property of the other shall also defend, at its sole cost and expense, on behalf of the other, any action, suit or proceeding which may be brought for the enforcement of such liens and shall pay any damage and discharge any judgment entered thereon.

## **11. Inspections**

- 11.1 BellSouth may conduct an inspection of Local Line's equipment and facilities in the Collocation Space(s) prior to the activation of facilities between Local Line's equipment and equipment of BellSouth. BellSouth may conduct an inspection if Local Line adds equipment and may otherwise conduct routine inspections at reasonable intervals mutually agreed upon by the Parties. BellSouth shall provide Local Line with a minimum of forty-eight (48) hours or two (2) business days, whichever is greater, advance notice of all such inspections. All costs of such inspection shall be borne by BellSouth.

## **12. Security and Safety Requirements**

- 12.1 Unless otherwise specified, Local Line will be required, at its own expense, to conduct a statewide investigation of criminal history records for each Local Line employee hired in the past five years being considered for work on the "BellSouth Premises", for

the states/counties where the Local Line employee has worked and lived for the past five years. Where state law does not permit statewide collection or reporting, an investigation of the applicable counties is acceptable. Local Line shall not be required to perform this investigation if an affiliated company of Local Line has performed an investigation of the Local Line employee seeking access, if such investigation meets the criteria set forth above. This requirement will not apply if Local Line has performed a pre-employment statewide investigation of criminal history records of the Local Line employee for the states/counties where the Local Line employee has worked and lived for the past five years or, where state law does not permit a statewide investigation, an investigation of the applicable counties.

- 12.2 Local Line will be required to administer to its personnel assigned to the “BellSouth Premises” security training either provided by BellSouth, or meeting criteria defined by BellSouth.
- 12.3 Local Line shall provide its employees and agents with picture identification, which must be worn and visible at all times while in the Collocation Space or other areas in or around the “BellSouth Premises”. The photo identification card shall bear, at a minimum, the employee’s name and photo and Local Line’s name. BellSouth reserves the right to remove from a “BellSouth Premises” any employee of Local Line not possessing identification issued by Local Line or who has violated any of BellSouth’s policies as outlined in the CLEC Security Training documents. Local Line shall not hold BellSouth harmless for any damages resulting from such removal of its personnel from a “BellSouth Premises”. Local Line shall be solely responsible for ensuring that any Guest(s) of Local Line is in compliance with all subsections of this Section.
- 12.4 Local Line shall not assign to the “BellSouth Premises” any personnel with records of felony criminal convictions. Local Line shall not assign to the “BellSouth Premises” any personnel with records of misdemeanor convictions, except for misdemeanor traffic violations, without advising BellSouth of the nature and gravity of the offense(s). BellSouth reserves the right to refuse building access to any Local Line personnel who have been identified to have misdemeanor criminal convictions. Notwithstanding the foregoing, in the event that Local Line chooses not to advise BellSouth of the nature and gravity of any misdemeanor conviction, Local Line may, in the alternative, certify to BellSouth that it shall not assign to the “BellSouth Premises” any personnel with records of misdemeanor convictions (other than misdemeanor traffic violations).
  - 12.4.1 Local Line shall not knowingly assign to the “BellSouth Premises” any individual who was a former employee of BellSouth and whose employment with BellSouth was terminated for a criminal offense whether or not BellSouth sought prosecution of the individual for the criminal offense.
  - 12.4.2 Local Line shall not knowingly assign to the “BellSouth Premises” any individual who was a former supplier of BellSouth and whose access to a “BellSouth Premises” was revoked due to commission of a criminal offense whether or not BellSouth sought prosecution of the individual for the criminal offense.

Version 3Q03: 11/12/2003



- 12.5 For each Local Line employee or agent hired by Local Line within five years of being considered for work on the "BellSouth Premises"; who requires access to a "BellSouth Premises" pursuant to this Attachment, Local Line shall furnish BellSouth, prior to an employee or agent gaining such access, a certification that the aforementioned background check and security training were completed. The certification will contain a statement that no felony convictions were found and certify that the employee completed the security training. If the employee's criminal history includes misdemeanor convictions, Local Line will disclose the nature of the convictions to BellSouth at that time. In the alternative, Local Line may certify to BellSouth that it shall not assign to the "BellSouth Premises" any personnel with records of misdemeanor convictions other than misdemeanor traffic violations.
- 12.5.1 For all other Local Line employees requiring access to a "BellSouth Premises" pursuant to this Attachment, Local Line shall furnish BellSouth, prior to an employee gaining such access, a certification that the employee is not subject to the requirements of Section 12.5 above and that security training was completed by the employee.
- 12.6 At BellSouth's request, Local Line shall promptly remove from the "BellSouth Premises" any employee of Local Line BellSouth does not wish to grant access to a "BellSouth Premises" 1) pursuant to any investigation conducted by BellSouth or 2) prior to the initiation of an investigation if an employee of Local Line is found interfering with the property or personnel of BellSouth or another collocated telecommunications carrier, provided that an investigation shall promptly be commenced by BellSouth.
- 12.7 Security Violations. BellSouth reserves the right to interview Local Line's employees, agents, or suppliers in the event of wrongdoing in or around BellSouth's property or involving BellSouth's or another collocated telecommunications carrier's property or personnel, provided that BellSouth shall provide reasonable notice to Local Line's Security representative of such interview. Local Line and its suppliers shall reasonably cooperate with BellSouth's investigation into allegations of wrongdoing or criminal conduct committed by, witnessed by, or involving Local Line's employees, agents, or suppliers. Additionally, BellSouth reserves the right to bill Local Line for all reasonable costs associated with investigations involving its employees, agents, or suppliers if it is established and mutually agreed in good faith that Local Line's employees, agents, or suppliers are responsible for the alleged act. BellSouth shall bill Local Line for BellSouth property, which is stolen or damaged where an investigation determines the culpability of Local Line's employees, agents, or suppliers and where Local Line agrees, in good faith, with the results of such investigation. Local Line shall notify BellSouth in writing immediately in the event that Local Line discovers one of its employees already working on the "BellSouth Premises" is a possible security risk. Upon request of the other Party, the Party who is the employer shall discipline consistent with its employment practices, up to and including removal from BellSouth's Premises, any employee found to have violated the security and safety requirements of this Section. Local Line shall not hold BellSouth harmless for any damages resulting from such removal of its personnel from a "BellSouth Premises".

- 12.8 Use of Supplies. Unauthorized use of equipment, supplies or other property by either Party, whether or not used routinely to provide telephone service will be strictly prohibited and handled appropriately. Costs associated with such unauthorized use may be charged to the offending Party, as may be all associated investigative costs.
- 12.9 Use of Official Lines. Except for non-toll calls necessary in the performance of their work, neither Party shall use the telephones of the other Party on BellSouth's Premises. Charges for unauthorized telephone calls may be charged to the offending Party, as may be all associated investigative costs.
- 12.10 Accountability. Full compliance with the Security requirements of this Section shall in no way limit the accountability of either Party to the other for the improper actions of its employees.

### **13. Destruction of Collocation Space**

- 13.1 In the event a Collocation Space is wholly or partially damaged by fire, windstorm, tornado, flood or by similar causes to such an extent as to be rendered wholly unsuitable for Local Line's permitted use hereunder, then either Party may elect within ten (10) calendar days after such damage, to terminate occupancy of the damaged Collocation Space, and if either Party shall so elect, by giving the other written notice of termination, both Parties shall stand released of and from further liability under the terms hereof. If the Collocation Space shall suffer only minor damage and shall not be rendered wholly unsuitable for Local Line's permitted use, or is damaged and the option to terminate is not exercised by either Party, BellSouth covenants and agrees to proceed promptly without expense to Local Line, except for improvements not to the property of BellSouth, to repair the damage. BellSouth shall have a reasonable time within which to rebuild or make any repairs, and such rebuilding and repairing shall be subject to delays caused by storms, shortages of labor and materials, government regulations, strikes, walkouts, and causes beyond the control of BellSouth, which causes shall not be construed as limiting factors, but as exemplary only. Local Line may, at its own expense, accelerate the rebuild of its collocated space and equipment provided however that a BellSouth Certified Supplier is used and the necessary space preparation has been completed. If Local Line's acceleration of the project increases the cost of the project, then those additional charges will be incurred by Local Line. Where allowed and where practical, Local Line may erect a temporary facility while BellSouth rebuilds or makes repairs. In all cases where the Collocation Space shall be rebuilt or repaired, Local Line shall be entitled to an equitable abatement of rent and other charges, depending upon the unsuitability of the Collocation Space for Local Line's permitted use, until such Collocation Space is fully repaired and restored and Local Line's equipment installed therein (but in no event later than thirty (30) calendar days after the Collocation Space is fully repaired and restored). Where Local Line has placed an Adjacent Arrangement pursuant to Section 3.4, Local Line shall have the sole responsibility to repair or replace said Adjacent Arrangement provided herein. Pursuant to this Section, BellSouth will restore the associated services to the Adjacent Arrangement.

Version 3Q03: 11/12/2003

**14. Eminent Domain**

- 14.1 If the whole of a Collocation Space or Adjacent Arrangement shall be taken by any public authority under the power of eminent domain, then this Attachment shall terminate with respect to such Collocation Space or Adjacent Arrangement as of the day possession shall be taken by such public authority and rent and other charges for the Collocation Space or Adjacent Arrangement shall be paid up to that day with proportionate refund by BellSouth of such rent and charges as may have been paid in advance for a period subsequent to the date of the taking. If any part of the Collocation Space or Adjacent Arrangement shall be taken under eminent domain, BellSouth and Local Line shall each have the right to terminate this Attachment with respect to such Collocation Space or Adjacent Arrangement and declare the same null and void, by written notice of such intention to the other Party within ten (10) calendar days after such taking.

**15. Nonexclusivity**

- 15.1 Local Line understands that this Attachment is not exclusive and that BellSouth may enter into similar agreements with other Parties. Assignment of space pursuant to all such agreements shall be determined by space availability and made on a first come, first served basis

## ENVIRONMENTAL AND SAFETY PRINCIPLES

The following principles provide basic guidance on environmental and safety issues when applying for and establishing Physical Collocation arrangements.

### 1. GENERAL PRINCIPLES

- 1.1 Compliance with Applicable Law. BellSouth and Local Line agree to comply with applicable federal, state, and local environmental and safety laws and regulations including U.S. Environmental Protection Agency (USEPA) regulations issued under the Clean Air Act (CAA), Clean Water Act (CWA), Resource Conservation and Recovery Act (RCRA), Comprehensive Environmental Response, Compensation and Liability Act (CERCLA), Superfund Amendments and Reauthorization Act (SARA), the Toxic Substances Control Act (TSCA), and OSHA regulations issued under the Occupational Safety and Health Act of 1970, as amended and NFPA and National Electrical Codes (NEC) and the NESC (Applicable Laws). Each Party shall notify the other if compliance inspections are conducted by regulatory agencies and/or citations are issued that relate to any aspect of this Attachment.
- 1.2 Notice. BellSouth and Local Line shall provide notice to the other, including Material Safety Data Sheets (MSDSs), of known and recognized physical hazards or Hazardous Chemicals existing on site or brought on site. A Hazardous Chemical inventory list is posted on an OSHA Poster and updated annually at each Central Office. This Poster is normally located near the front entrance of the building or in the lounge area. Each Party is required to provide specific notice for known potential Imminent Danger conditions. Local Line should contact 1-800-743-6737 for any BellSouth MSDS required.
- 1.3 Practices/Procedures. BellSouth may make available additional environmental control procedures for Local Line to follow when working at a "BellSouth Premises" (See Section 2, below). These practices/procedures will represent the regular work practices required to be followed by the employees and suppliers of BellSouth for environmental protection. Local Line will require its suppliers, agents and others accessing the "BellSouth Premises" to comply with these practices. Section 2 lists the Environmental categories where BST practices should be followed by Local Line when operating in the "BellSouth Premises".
- 1.4 Environmental and Safety Inspections. BellSouth reserves the right to inspect the Local Line space with proper notification. BellSouth reserves the right to stop any Local Line work operation that imposes Imminent Danger to the environment, employees or other persons in the area on BellSouth's Premises.
- 1.5 Hazardous Materials Brought On Site. Any hazardous materials brought into, used, stored or abandoned at the "BellSouth Premises" by Local Line are owned by Local Line. Local Line will indemnify BellSouth for claims, lawsuits or damages to persons or property caused by these materials. Without prior written BellSouth approval, no substantial new safety or environmental hazards can be created by Local Line or different hazardous materials used by Local Line at a "BellSouth Premises". Local Line must demonstrate adequate emergency response capabilities for its materials used or remaining at the "BellSouth Premises".

- 1.6 Spills and Releases. When contamination is discovered at a “BellSouth Premises”, either Party discovering the condition must notify the other Party. All Spills or Releases of regulated materials will immediately be reported by Local Line to BellSouth.
- 1.7 Coordinated Environmental Plans and Permits. BellSouth and Local Line will coordinate plans, permits or information required to be submitted to government agencies, such as emergency response plans, spill prevention control and countermeasures (SPCC) plans and community reporting. If fees are associated with filing, BellSouth and Local Line will develop a cost sharing procedure. If BellSouth’s permit or EPA identification number must be used, Local Line must comply with all of BellSouth’s permit conditions and environmental processes, including environmental “best management practices (BMP)” (see Section 2, below) and/or selection of BST disposition vendors and disposal sites.
- 1.8 Environmental and Safety Indemnification. BellSouth and Local Line shall indemnify, defend and hold harmless the other Party from and against any claims (including, without limitation, third-party claims for personal injury or death or real or personal property damage), judgments, damages (including direct and indirect damages and punitive damages), penalties, fines, forfeitures, costs, liabilities, interest and losses arising in connection with the violation or alleged violation of any Applicable Law or contractual obligation or the presence or alleged presence of contamination arising out of the acts or omissions of the indemnifying Party, its agents, suppliers, or employees concerning its operations at the “BellSouth Premises”.

**2. CATEGORIES FOR CONSIDERATION OF ENVIRONMENTAL ISSUES**

- 2.1 When performing functions that fall under the following Environmental categories on BellSouth’s Premises, Local Line agrees to comply with the applicable sections of the current issue of BellSouth’s Environmental and Safety Methods and Procedures (M&Ps), incorporated herein by this reference. Local Line further agrees to cooperate with BellSouth to ensure that Local Line’s employees, agents, and/or suppliers are knowledgeable of and satisfy those provisions of BellSouth’s Environmental M&Ps which apply to the specific Environmental function being performed by Local Line, its employees, agents and/or suppliers.
- 2.2 The most current version of the reference documentation must be requested from Local Line’s BellSouth Regional Contract Manager (RCM) (f/k/a Account Team Collocation Coordinator – ATCC).

ENVIRONMENTAL CATEGORIES	ENVIRONMENTAL ISSUES	ADDRESSED BY THE FOLLOWING DOCUMENTATION
Disposal of hazardous material or other regulated	Compliance with all applicable local, state, & federal laws and	Std T&C 450

Version 3Q03: 11/12/2003

material (e.g., batteries, fluorescent tubes, solvents & cleaning materials)	regulations  Pollution liability insurance  EVET approval of supplier	Fact Sheet Series 17000  Std T&C 660-3  Approved Environmental Vendor List (Contact RCM Representative)
Emergency response	Hazmat/waste release/spill fire safety emergency	Fact Sheet Series 17000 Building Emergency Operations Plan (EOP) (specific to and located on BellSouth's Premises)
Contract labor/outsourcing for services with environmental implications to be performed on "BellSouth Premises" (e.g., disposition of hazardous material/waste; maintenance of storage tanks)	Compliance with all applicable local, state, & federal laws and regulations  Performance of services in accordance with BST's environmental M&Ps  Insurance	Std T&C 450  Std T&C 450-B (Contact RCM Representative for copy of appropriate E/S M&Ps.)  Std T&C 660
Transportation of hazardous material	Compliance with all applicable local, state, & federal laws and regulations  Pollution liability insurance  EVET approval of supplier	Std T&C 450 Fact Sheet Series 17000  Std T&C 660-3  Approved Environmental Vendor List (Contact RCM Representative)
Maintenance/operations work which may produce a waste  Other maintenance work	Compliance with all applicable local, state, & federal laws and regulations  Protection of BST employees and equipment	Std T&C 450  29CFR 1910.147 (OSHA Standard) 29CFR 1910 Subpart O (OSHA Standard)
Janitorial services	All waste removal and disposal must conform to all applicable federal, state and local	Procurement Manager (CRES Related Matters)-BST Supply

	<p>regulations</p> <p>All Hazardous Material and Waste</p> <p>Asbestos notification and protection of employees and equipment</p>	<p>Chain Services</p> <p>Fact Sheet Series 17000</p> <p>GU-BTEN-001BT, Chapter 3 BSP 010-170-001BS (Hazcom)</p>
Manhole cleaning	<p>Compliance with all applicable local, state, &amp; federal laws and regulations</p> <p>Pollution liability insurance</p> <p>EVET approval of supplier</p>	<p>Std T&amp;C 450</p> <p>Fact Sheet 14050</p> <p>BSP 620-145-011PR</p> <p>Issue A, August 1996</p> <p>Std T&amp;C 660-3</p> <p>Approved Environmental Vendor List (Contact RCM Representative)</p>
Removing or disturbing building materials that may contain asbestos	Asbestos work practices	<p>GU-BTEN-001BT, Chapter 3 For questions regarding removing or disturbing materials that contain asbestos, call the BellSouth Building Service Center: AL, MS, TN, KY &amp; LA (local area code) 557-6194 FL, GA, NC &amp; SC (local area code) 780-2740</p>

### 3. DEFINITIONS

Generator. Under RCRA, the person whose act produces a Hazardous Waste, as defined in 40 CFR 261, or whose act first causes a Hazardous Waste to become subject to regulation. The Generator is legally responsible for the proper management and disposal of Hazardous Wastes in accordance with regulations.

Hazardous Chemical. As defined in the U.S. Occupational Safety and Health (OSHA) hazard communication standard (29 CFR 1910.1200), any chemical which is a health hazard or physical hazard.

Hazardous Waste. As defined in Section 1004 of RCRA.

Imminent Danger. Any conditions or practices at a "BellSouth Premises" which are such that a danger exists which could reasonably be expected to cause immediate death or serious harm to people or immediate significant damage to the environment or natural resources.

Spill or Release. As defined in Section 101 of CERCLA.

#### 4. ACRONYMS

RCM – Regional Collocation Manager (f/k/a Account Team Collocation Coordinator)

BST – BellSouth Telecommunications

CRES – Corporate Real Estate and Services (formerly PS&M)

DEC/LDEC - Department Environmental Coordinator/Local Department Environmental Coordinator

E/S – Environmental/Safety

EVET - Environmental Vendor Evaluation Team

GU-BTEN-001BT - BellSouth Environmental Methods and Procedures

NESC - National Electrical Safety Codes

P&SM - Property & Services Management

Std T&C - Standard Terms & Conditions



**Attachment 4**

**Remote Site Physical Collocation**

## BELLSOUTH

### REMOTE SITE PHYSICAL COLLOCATION

#### 1. Scope of Attachment

- 1.1 Scope of Attachment. The rates, terms, and conditions contained within this Attachment shall only apply when Local Line is occupying the collocation space as a sole occupant or as a Host within a Remote Site Location (“Remote Collocation Space”) pursuant to this Attachment.
- 1.2 Right to occupy. BellSouth shall offer to Local Line Remote Collocation Space on rates, terms, and conditions that are just, reasonable, non-discriminatory and consistent with the rules of the Federal Communications Commission (“FCC”). Subject to the rates, terms, and conditions of this Attachment, where space is available and collocation is technically feasible, BellSouth will allow Local Line to occupy that certain area designated by BellSouth within a BellSouth Remote Site Location, or on BellSouth property upon which the BellSouth Remote Site Location is located, of a size, which is specified by Local Line and agreed to by BellSouth. BellSouth Remote Site Locations include cabinets, huts, and controlled environmental vaults owned or leased by BellSouth that house BellSouth Network Facilities. To the extent this Attachment does not include all the necessary rates, terms and conditions for BellSouth Remote Site Locations other than cabinets, huts and controlled environmental vaults, the Parties will negotiate said rates, terms, and conditions upon request for collocation at BellSouth Remote Site Locations other than those specified above.
- 1.3 Space Reservation.
- 1.3.1 In all states other than Florida, the number of racks/bays specified by Local Line may contemplate a request for space sufficient to accommodate Local Line’s growth within a two-year period.
- 1.3.2 In the state of Florida, the number of racks/bays specified by Local Line may contemplate a request for space sufficient to accommodate Local Line’s growth within an eighteen (18) month period.
- 1.3.3 Neither BellSouth nor any of BellSouth’s affiliates may reserve space for future use on more preferential terms than those set forth above.
- 1.4 Third Party Property. If the Premises, or the property on which it is located, is leased by BellSouth from a Third Party or otherwise controlled by a Third Party, special

considerations and intervals may apply in addition to the terms and conditions of this Attachment. Additionally, where BellSouth notifies Local Line that BellSouth's agreement with a Third Party does not grant BellSouth the ability to provide access and use rights to others, upon Local Line's request, BellSouth will use its best efforts to obtain the owner's consent and to otherwise secure such rights for Local Line. Local Line agrees to reimburse BellSouth for the reasonable and demonstrable costs incurred by BellSouth in obtaining such rights for Local Line. In cases where a Third Party agreement does not grant BellSouth the right to provide access and use rights to others as contemplated by this Attachment and BellSouth, despite its best efforts, is unable to secure such access and use rights for Local Line as above, Local Line shall be responsible for obtaining such permission to access and use such property. BellSouth shall cooperate with Local Line in obtaining such permission.

- 1.5 Space Reclamation. In the event of space exhaust within a Remote Site Location, BellSouth may include in its documentation for the Petition for Waiver filing any unutilized space in the Remote Site Location. Local Line will be responsible for any justification of unutilized space within its Remote Collocation Space, if the Commission requires such justification.
- 1.6 Use of Space. Local Line shall use the Remote Collocation Space for the purposes of installing, maintaining and operating Local Line's equipment (to include testing and monitoring equipment) necessary for interconnection with BellSouth services and facilities or for accessing BellSouth unbundled network elements (UNEs) for the provision of telecommunications services, as specifically set forth in this Agreement. The Remote Collocation Space may be used for no other purposes except as specifically described herein or in any amendment hereto.
- 1.7 Rates and charges. Local Line agrees to pay the rates and charges identified in Exhibit B attached hereto.
- 1.8 If any due date contained in this Attachment falls on a weekend or National holiday, then the due date will be the next business day thereafter. For intervals of ten (10) calendar days or less National holidays will be excluded.
- 1.9 The Parties agree to comply with all applicable federal, state, county, local and administrative laws, rules, ordinances, regulations and codes in the performance of their obligations hereunder.
2. **Space Availability Report**
- 2.1 Space Availability Report. Upon request from Local Line, BellSouth will provide a written report ("Space Availability Report"), describing in detail the space that is available for collocation and specifying the amount of Remote Collocation Space available at the Remote Site Location requested, the number of collocators present at the Remote Site Location, any modifications in the use of the space since the last

report on the Remote Site Location requested and the measures BellSouth is taking to make additional space available for collocation arrangements. A Space Availability Report does not reserve space at the Remote Site Location.

- 2.1.1 The request from Local Line for a Space Availability Report must be written and must include the Common Language Location Identification (“CLLI”) code for both the Remote Site Location and the serving wire center. The CLLI code information for the serving wire center is located in the National Exchange Carrier Association (NECA) Tariff FCC No. 4. If Local Line is unable to obtain the CLLI code for the Remote Site Location from, for example, a site visit to the remote site, Local Line may request the CLLI code from BellSouth. To obtain a CLLI code for a Remote Site Location directly from BellSouth, Local Line should submit to BellSouth a Remote Site Interconnection Request for the serving wire center CLLI code prior to submitting its request for a Space Availability Report. Local Line should complete all the requested information and submit the Request to BellSouth. BellSouth will bill the applicable fee upon receipt of the request.
- 2.1.2 BellSouth will respond to a request for a Space Availability Report for a particular Remote Site Location within ten (10) calendar days of receipt of such request. BellSouth will make best efforts to respond in ten (10) calendar days to such a request when the request includes from two (2) to five (5) Remote Site Locations within the same state. The response time for requests of more than five (5) Remote Site Locations shall be negotiated between the Parties. If BellSouth cannot meet the ten (10) calendar day response time, BellSouth shall notify Local Line and inform Local Line of the time frame under which it can respond.
- 2.2 Remote Terminal information. Upon request, BellSouth will provide Local Line with the following information concerning BellSouth’s remote terminals: (i) the address of the remote terminal; (ii) the CLLI code of the remote terminal; (iii) the carrier serving area of the remote terminal; (iv) the designation of which remote terminals subtend a particular central office; and (v) the number and address of customers that are served by a particular remote terminal.
- 2.2.1 BellSouth will provide this information on a first come, first served basis within thirty (30) calendar days of a Local Line request subject to the following conditions: (i) the information will only be provided on a CD in the same format in which it appears in BellSouth’s systems; (ii) the information will only be provided for each serving wire center designated by Local Line, up to a maximum of thirty (30) wire centers per Local Line request per month per state, and up to for a maximum of one hundred twenty (120) wire centers total per month per state for all CLECs; and (iii) Local Line agrees to pay the costs incurred by BellSouth in providing the information.
3. **Collocation Options**
- 3.1 Cageless. BellSouth shall allow Local Line to collocate Local Line’s equipment and facilities without requiring the construction of a cage or similar structure. BellSouth

shall allow Local Line to have direct access to Local Line's equipment and facilities in accordance with Section 5.8. BellSouth shall make cageless collocation available in single rack/bay increments. Except where Local Line's equipment requires special technical considerations (e.g., special cable racking or isolated ground plane), BellSouth shall assign cageless Remote Collocation Space in conventional equipment rack lineups where feasible. For equipment requiring special technical considerations, Local Line must provide the equipment layout, including spatial dimensions for such equipment pursuant to generic requirements contained in Telcordia GR-63-Core, and shall be responsible for compliance with all special technical requirements associated with such equipment pursuant to Section 7.6 following.

3.2 Caged. At Local Line's expense, Local Line may arrange with a Supplier certified by BellSouth ("BellSouth Certified Supplier") to construct a collocation arrangement enclosure, where technically feasible as that term has been defined by the FCC, in accordance with BellSouth's Technical References (TR) ("Specifications") prior to starting equipment installation. BellSouth will provide Specifications upon request. Local Line's BellSouth Certified Supplier shall be responsible for filing and receiving any and all necessary permits and/or licenses for such construction. BellSouth shall cooperate with Local Line and provide, at Local Line's expense, the documentation, including existing building architectural drawings, enclosure drawings, and Specifications required and necessary for Local Line's BellSouth Certified Supplier to obtain the zoning, permits and/or other licenses. Local Line's BellSouth Certified Supplier shall bill Local Line directly for all work performed for Local Line pursuant to this Attachment and BellSouth shall have no liability for nor responsibility to pay such charges imposed by Local Line's BellSouth Certified Supplier. Local Line must provide the local BellSouth Remote Site Location contact with two Access Keys used to enter the locked enclosure. Except in case of emergency, BellSouth will not access Local Line's locked enclosure prior to notifying Local Line at least forty-eight (48) hours before access to the Remote Site Location is required. Upon request, BellSouth shall construct the enclosure for Local Line.

3.2.1 BellSouth may elect to review Local Line's plans and specifications prior to allowing construction to start to ensure compliance with BellSouth's Specifications. Notification to Local Line indicating BellSouth's desire to execute this review will be provided in BellSouth's response to the Application, if Local Line has indicated their desire to construct their own enclosure. If Local Line's Application does not indicate their desire to construct their own enclosure, but their firm order does indicate their desire to construct their own enclosure, then notification to review will be given within ten (10) calendar days after the Firm Order date. BellSouth shall complete its review within fifteen (15) calendar days after the receipt of the plans and specifications. Regardless of whether or not BellSouth elects to review Local Line's plans and specifications, BellSouth reserves the right to inspect the enclosure after construction to make sure it is constructed according to the submitted plans and specifications and/or BellSouth's Specifications, as applicable. BellSouth shall require Local Line to remove or correct within seven (7) calendar days at Local Line's expense any structure

that does not meet these plans and specifications or, where applicable, BellSouth's Specifications.

- 3.3 Shared Collocation. Local Line may allow other telecommunications carriers to share Local Line's Remote Collocation Space pursuant to terms and conditions agreed to by Local Line ("Host") and other telecommunications carriers ("Guests") and pursuant to this Section, except where the BellSouth Remote Site Location is located within a leased space and BellSouth is prohibited by said lease from offering such an option or is located on property for which BellSouth holds an easement and such easement does not permit such an option. Local Line shall notify BellSouth in writing upon execution of any agreement between the Host and its Guest within ten (10) calendar days of its execution and prior to any Firm Order. Further, such notice shall include the name of the Guest(s) and the term of the agreement, and shall contain a certification by Local Line that said agreement imposes upon the Guest(s) the same terms and conditions for Remote Collocation Space as set forth in this Attachment between BellSouth and Local Line.
- 3.3.1 Local Line, as the Host, shall be the sole interface and responsible Party to BellSouth for assessment of rates and charges contained within this Attachment and for the purposes of ensuring that the safety and security requirements of this Attachment are fully complied with by the Guest, its employees and agents. BellSouth shall provide Local Line with a proration of the costs of the Remote Collocation Space based on the number of collocators and the space used by each with a minimum charge of one (1) bay/rack per Host/Guest. In those instances where the Host permits a Guest to use a shelf within the Host's bay, BellSouth will not prorate the cost of the bay. In all states other than Florida, and in addition to the foregoing, Local Line shall be the responsible party to BellSouth for the purpose of submitting applications for bay/rack placement for the Guest. In Florida the Guest may directly submit bay/rack placement applications using the Host's access carrier name abbreviation (ACNA). A separate Guest application shall require the assessment of an Application Fee, as set forth in Exhibit B, which will be charged to the Host. BellSouth shall bill this nonrecurring fee on the date that BellSouth provides its written response ("Application Response").
- 3.3.2 Notwithstanding the foregoing, the Guest may arrange directly with BellSouth for the provision of the interconnecting facilities between BellSouth and the Guest and for the provision of the services and access to unbundled network elements. The bill for these interconnecting facilities, services and access to UNEs will be charged to the Guest pursuant to the applicable tariff or the Guest's Interconnection Agreement with BellSouth:
- 3.3.3 Local Line shall indemnify and hold harmless BellSouth from any and all claims, actions, causes of action, of whatever kind or nature arising out of the presence of Local Line's Guest(s) in the Remote Collocation Space except to the extent caused by BellSouth's sole negligence, gross negligence, or willful misconduct.

- 3.4 Adjacent Collocation. Subject to technical feasibility and space availability, BellSouth will permit adjacent Remote Site collocation arrangements (“Remote Site Adjacent Arrangement”) on the property on which the Remote Site is located when space within the Remote Site Location is legitimately exhausted, where the Remote Site Adjacent Arrangement does not interfere with access to existing or planned structures or facilities on the Remote Site Location property. The Remote Site Adjacent Arrangement shall be constructed or procured by Local Line and in conformance with BellSouth’s design and construction Specifications. Further, Local Line shall construct, procure, maintain and operate said Remote Site Adjacent Arrangement(s) pursuant to all of the terms and conditions set forth in this Attachment. Rates shall be negotiated at the time of the application for the Remote Site Adjacent Arrangement.
- 3.4.1 Should Local Line elect Adjacent Collocation, Local Line must arrange with a BellSouth Certified Supplier to construct a Remote Site Adjacent Arrangement structure in accordance with BellSouth’s Specifications. Where local building codes require enclosure specifications more stringent than BellSouth’s Specifications, Local Line and Local Line’s BellSouth Certified Supplier must comply with local building code requirements. Local Line’s BellSouth Certified Supplier shall be responsible for filing and receiving any and all necessary zoning, permits and/or licenses for such construction. Local Line’s BellSouth Certified Supplier shall bill Local Line directly for all work performed for Local Line pursuant to this Attachment and BellSouth shall have no liability for nor responsibility to pay such charges imposed by Local Line’s BellSouth Certified Supplier. Local Line must provide the local BellSouth Remote Site Location contact with two cards, keys or other access device used to enter the locked enclosure. Except in cases of emergency, BellSouth shall not access Local Line’s locked enclosure prior to notifying Local Line at least forty-eight (48) hours or two (2) business days, whichever is greater, before access to the locked enclosure is required.
- 3.4.2 Local Line must submit its plans and specifications to BellSouth with its Firm Order. BellSouth shall review Local Line’s plans and specifications prior to construction of a Remote Site Adjacent Arrangement(s) to ensure compliance with BellSouth’s Specifications. BellSouth shall complete its review within fifteen (15) calendar days after receipt of plans and specifications. BellSouth may inspect the Remote Site Adjacent Arrangement(s) during and after construction to confirm it is constructed according to the submitted plans and specifications. BellSouth shall require Local Line to remove or correct within seven (7) calendar days at Local Line’s expense any structure that does not meet these plans and specifications or, where applicable, BellSouth’s Specifications.
- 3.4.3 Local Line shall provide a concrete pad, the structure housing the arrangement, heating/ventilation/air conditioning (“HVAC”), lighting, and all facilities that connect the structure (i.e. racking, conduits, etc.) to the BellSouth point of demarcation. At Local Line’s option, and where the local authority having jurisdiction permits, BellSouth shall provide an AC power source and access to physical collocation

services and facilities subject to the same nondiscriminatory requirements as applicable to any other physical collocation arrangement. Local Line's BellSouth Certified Supplier shall be responsible, at Local Line's expense, for filing and receiving any and all necessary zoning, permits and/or licenses for such arrangement. BellSouth shall allow Shared Collocation within a Remote Site Adjacent Arrangement pursuant to the terms and conditions set forth herein.

- 3.5 Co-carrier cross-connect (CCXC). The primary purpose of collocation is for a collocated telecommunications carrier to interconnect with BellSouth's network or to access BellSouth's unbundled network elements for the provision of telecommunications services within a BellSouth Premises. BellSouth will permit Local Line to interconnect between its virtual or physical collocation arrangements and those of another collocated telecommunications carrier within the same Remote Site Location. Both Local Line's agreement and the other collocated telecommunications carrier's agreement must contain rates, terms and conditions for CCXC language. At no point in time shall Local Line use the Remote Collocation Space for the sole or primary purpose of cross connecting to other collocated telecommunications carriers.
- 3.5.1 Local Line must use a BellSouth Certified Supplier to place the CCXC. The CCXC shall be provisioned through facilities owned by Local Line. Such connections to other collocated telecommunications carriers may be made using either optical or electrical facilities. In cases where Local Line's equipment and the equipment of the other collocated telecommunications carrier are located in contiguous caged Collocation Spaces, Local Line will have the option of using Local Line's own technicians to deploy co-carrier cross connects using either electrical or optical facilities between the sets of equipment and construct its own dedicated cable support structure. Local Line shall deploy such optical or electrical connections directly between its own facilities and the facilities of other collocated telecommunications carriers without being routed through BellSouth equipment. Local Line shall not provision CCXC on any BellSouth distribution frame, POT (Point of Termination) Bay, DSX (Digital System Cross-connect) or LGX (Light Guide Cross-connect). Local Line is responsible for ensuring the integrity of the signal.
- 3.5.2 Local Line shall be responsible for providing a letter of authorization ("LOA") to BellSouth from the other collocated telecommunications carrier prior to installing the CCXC. Local Line-provisioned CCXC shall utilize common cable support structure. There will be a recurring charge per linear foot, per cable, of common cable support structure used. In the case of two contiguous caged collocation arrangements, Local Line will have the option of using Local Line's own technicians to construct its own dedicated support structure.
- 3.5.3 To order CCXCs, Local Line must submit an Application. If no modification to the Remote Collocation Space is requested other than the placement of CCXCs, the Subsequent Application Fee for CCXCs, as defined in Exhibit B, will apply. If modifications in addition to the placement of CCXCs are requested, the Application



Fee will apply. This nonrecurring fee will be billed by BellSouth on the date that BellSouth provides an Application Response.

4. **Occupancy**

4.1 **Occupancy.** BellSouth will notify Local Line in writing that the Remote Collocation Space is ready for occupancy ("Space Ready Date"). Local Line will schedule and complete an acceptance walkthrough of each Remote Collocation Space with BellSouth within fifteen (15) calendar days of BellSouth's notifying Local Line that Remote Collocation Space is ready for occupancy ("Space Ready Date"). BellSouth will correct any deviations to Local Line's original or jointly amended requirements within seven (7) calendar days after the walkthrough, unless the Parties jointly agree upon a different time frame, and BellSouth shall establish a new Space Ready Date. Another acceptance walkthrough will then be scheduled and conducted within fifteen (15) calendar days of the new Space Ready Date. This follow-up acceptance walkthrough will be limited to those items identified in the initial walkthrough. If Local Line has met the fifteen (15) calendar day interval(s), billing will begin upon the date of Local Line's acceptance of the Collocation Space ("Space Acceptance Date"). In the event that Local Line fails to complete an acceptance walkthrough within this fifteen (15) calendar day interval, the Remote Collocation Space shall be deemed accepted by Local Line on the Space Ready Date and billing will commence from that date. If Local Line decides to occupy the space prior to the Space Ready Date, the date Local Line occupies the space becomes the new Space Acceptance Date and billing begins from that date. Local Line must notify BellSouth in writing that collocation equipment installation is complete and is operational with BellSouth's network. BellSouth may, at its option, not accept orders for cross connects until receipt of such notice. For purposes of this paragraph, Local Line's telecommunications equipment will be deemed operational when cross-connected to BellSouth's network for the purpose of service provision.

4.2 **Termination of Occupancy.** In addition to any other provisions addressing termination of occupancy in this Attachment, Local Line may terminate occupancy in a particular Remote Collocation Space by submitting an Application requesting termination of occupancy; such termination shall be effective upon BellSouth's acceptance of the Space Relinquishment Form. Billing for monthly recurring charges will cease on the date Local Line and BellSouth conduct an inspection of the terminated space and jointly sign off on the Space Relinquishment Form or on the date that Local Line signs off on the Space Relinquishment Form and sends the form to BellSouth if a subsequent inspection of the terminated space by BellSouth reveals no discrepancies. If the subsequent inspection by BellSouth reveals discrepancies, billing will cease on the date that BellSouth and Local Line jointly conduct an inspection which confirms that Local Line has corrected the discrepancies. An Application Fee will not apply for termination of occupancy. BellSouth may terminate Local Line's right to occupy the Remote Collocation Space in the event Local Line fails to comply with any provision of this Agreement.

- 4.2.1 Upon termination of occupancy, Local Line at its expense shall remove its equipment and other property from the Remote Collocation Space. Local Line shall have thirty (30) calendar days from the Bona Fide Firm Order ("BFFO") Application Date ("Termination Date") to complete such removal, including the removal of all equipment and facilities of Local Line's Guest(s), unless Local Line's Guest(s) has assumed responsibility for the Remote Collocation Space housing the Guest(s)'s equipment and executed the documentation required by BellSouth prior to such removal date. Local Line shall continue payment of monthly fees to BellSouth until such date as Local Line, and if applicable Local Line's Guest(s), has fully vacated the Remote Collocation Space and the Space Relinquish Form has been accepted by BellSouth. Should Local Line or Local Line's Guest(s) fail to vacate the Remote Collocation Space within thirty (30) calendar days from the Termination Date, BellSouth shall have the right to remove the equipment and dispose of the equipment and other property of Local Line or Local Line's Guest(s), in any manner that BellSouth deems fit, at Local Line's expense and with no liability whatsoever for Local Line's or Local Line's Guest(s)'s property. Upon termination of Local Line's right to occupy Remote Collocation Space, the Remote Collocation Space will revert back to BellSouth, and Local Line shall surrender such Remote Collocation Space to BellSouth in the same condition as when first occupied by the Local Line except for ordinary wear and tear unless otherwise agreed to by the Parties. For CEVs and huts Local Line's BellSouth Certified Supplier shall be responsible for updating and making any necessary changes to BellSouth's records as required by BellSouth's Specifications including but not limited to Record Drawings and ERMA Records. Local Line shall be responsible for the cost of removing any Local Line constructed enclosure, together with all support structures (e.g., racking, conduits, or power cables), at the termination of occupancy and restoring the grounds to their original condition.

## 5. Use of Remote Collocation Space

- 5.1 Equipment Type. BellSouth permits the collocation of any type of equipment necessary for interconnection to BellSouth's network or for access to BellSouth's unbundled network elements in the provision of telecommunications services, as the term "necessary" is defined by FCC 47 C.F.R. Section 51.323 (b). The primary purpose and function of any equipment collocated in a Remote Collocation Space must be for interconnection to BellSouth's network or for access to BellSouth's unbundled network elements in the provision of telecommunications services.
- 5.1.1 Examples of equipment that would not be considered necessary include but are not limited to: traditional circuit switching equipment, equipment used exclusively for call-related databases, computer servers used exclusively for providing information services, operations support system (OSS) equipment used to support collocated telecommunications carrier network operations, equipment that generates customer orders, manages trouble tickets or inventory, or stores customer records in centralized databases, etc. BellSouth will determine upon receipt of an application if the requested equipment is necessary based on the criteria established by the FCC.

Multifunctional equipment placed on BellSouth's Premises must not place any greater relative burden on BellSouth's property than comparable single-function equipment. BellSouth reserves the right to permit collocation of any equipment on a nondiscriminatory basis.

- 5.1.2 Such equipment must, at a minimum, meet the following Telcordia Network Equipment Building Systems (NEBS) General Equipment Requirements: Criteria Level 3 requirements as outlined in the Telcordia Special Report SR-3580, Issue 1. Except where otherwise required by a Commission, BellSouth shall comply with the applicable FCC rules relating to denial of collocation based on Local Line's failure to comply with this Section.
- 5.1.2.1 All Local Line equipment installation shall comply with BellSouth TR 73503-11h, "Grounding - Engineering Procedures". Metallic cable sheaths and metallic strength members of optical fiber cables as well as the metallic cable sheaths of all copper conductor cables shall be bonded to the designated grounding bus for the Remote Site Location. All copper conductor pairs, working and non-working, shall be equipped with a solid-state protector unit (over-voltage protection only), which has been listed by a nationally recognized testing laboratory.
- 5.1.3 Local Line shall identify to BellSouth whenever Local Line submits a Method of Procedure ("MOP") adding equipment to Local Line's Remote Collocation Space all UCC-1 lien holders or other entities that have a financial interest, secured or otherwise, in the equipment in Local Line's Remote Collocation Space. Local Line shall submit a copy of the list of any lien holders or other entities that have a financial interest to Local Line's ATCC Representative.
- 5.2 Local Line shall not use the Remote Collocation Space for marketing purposes nor shall it place any identifying signs or markings in the area surrounding the Remote Collocation Space or on the grounds of the Remote Site Location.
- 5.3 Local Line shall place a plaque or other identification affixed to Local Line's equipment to identify Local Line's equipment, including a list of emergency contacts with telephone numbers.
- 5.4 Entrance Facilities. Local Line may elect to place Local Line-owned or Local Line-leased fiber entrance facilities into the Remote Collocation Space. BellSouth will designate the point of interconnection at the Remote Site Location housing the Remote Collocation Space, which is physically accessible by both Parties. Local Line will provide and place copper cable through conduit from the Remote Collocation Space to the Feeder Distribution Interface to the splice location of sufficient length for splicing by BellSouth. Local Line must contact BellSouth for instructions prior to placing the entrance facility cable. Local Line is responsible for maintenance of the entrance facilities.

- 5.4.1 Shared Use. Local Line may utilize spare capacity on an existing interconnector entrance facility for the purpose of providing an entrance facility to Local Line's collocation arrangement within the same BellSouth Remote Site Location. BellSouth shall allow splicing to the entrance facility, provided that the fiber is non-working fiber. Local Line must arrange with BellSouth in accordance with BellSouth's Special Construction Procedures, RL93-11-030BT, and provide a LOA from the other telecommunications carrier for BellSouth to splice the Local Line provided riser cable to the spare capacity on the entrance facility. If Local Line desires to allow another telecommunications carrier to use its entrance facilities, then that telecommunications carrier must arrange with BellSouth in accordance with BellSouth's Special Construction Procedures, RL93-11-030BT, and provide a LOA from Local Line for BellSouth to splice that telecommunications carrier's provided riser cable to the spare capacity on Local Line's entrance facility.
- 5.5 Demarcation Point. BellSouth will designate the point(s) of demarcation between Local Line's equipment and/or network and BellSouth's network. Each Party will be responsible for maintenance and operation of all equipment/facilities on its side of the demarcation point. Local Line or its agent must perform all required maintenance to Local Line equipment/facilities on its side of the demarcation point, pursuant to Section 5.6, following.
- 5.6 Local Line's Equipment and Facilities. Local Line, or if required by this Attachment, Local Line's BellSouth Certified Supplier, is solely responsible for the design, engineering, installation, testing, provisioning, performance, monitoring, maintenance and repair of the equipment and facilities used by Local Line which must be performed in compliance with all applicable BellSouth Specifications. Such equipment and facilities may include but are not limited to cable(s), equipment, and point of termination connections. Local Line and its selected BellSouth Certified Supplier must follow and comply with all BellSouth requirements outlined in BellSouth's TR 73503, TR 73519, TR 73572, and TR 73564.
- 5.7 BellSouth's Access to Remote Collocation Space. From time to time BellSouth may require access to the Remote Collocation Space. BellSouth retains the right to access the Remote Collocation Space for the purpose of making BellSouth equipment and Remote Site Location modifications. Except in case of emergency, BellSouth will give notice to Local Line at least forty-eight (48) hours before access to the Remote Collocation Space is required. Local Line may elect to be present whenever BellSouth performs work in the Collocation Space. The Parties agree that Local Line will not bear any of the expense associated with this work.
- 5.8 Access. Pursuant to Section 12, Local Line shall have access to the Remote Collocation Space twenty-four (24) hours a day, seven (7) days a week. Local Line agrees to provide the name and social security number or date of birth or driver's license number of each employee, supplier, or agents of Local Line or Local Line's Guests to be provided with access keys or cards ("Access Keys") prior to the issuance

of said Access Keys using form RF-2906-C "CLEC and CLEC Certified Supplier Access Request and Acknowledgement". Key acknowledgement forms, "Collocation Acknowledgement Sheet" for access cards and "Key Acknowledgement Form" for keys, must be signed by Local Line and returned to BellSouth Access Management within fifteen (15) calendar days of Local Line's receipt. Failure to return properly acknowledged forms will result in the holding of subsequent requests until acknowledgements are current. Access Keys shall not be duplicated under any circumstances. Local Line agrees to be responsible for all Access Keys and for the return of all said Access Keys in the possession of Local Line's employees, suppliers, Guests, or agents after termination of the employment relationship, contractual obligation with Local Line or upon the termination of this Attachment or the termination of occupancy of an individual Remote Collocation Space arrangement.

- 5.8.1 BellSouth will permit one accompanied site visit to Local Line's designated collocation arrangement location after receipt of the BFFO without charge to Local Line. Local Line must submit to BellSouth the completed Access Control Request Form for all employees or agents requiring access to the BellSouth Remote Site Location a minimum of thirty (30) calendar days prior to the date Local Line desires access to the Remote Collocation Space. In order to permit reasonable access during construction of the Remote Collocation Space, Local Line may submit such a request at any time subsequent to BellSouth's receipt of the BFFO. In the event Local Line desires access to the Remote Collocation Space after submitting such a request but prior to access being approved, in addition to the first accompanied free visit, BellSouth shall permit Local Line to access the Remote Collocation Space accompanied by a security escort at Local Line's expense. Local Line must request escorted access at least three (3) business days prior to the date such access is desired.
- 5.9 Lost or Stolen Access Keys. Local Line shall notify BellSouth in writing immediately in the case of lost or stolen Access Keys. Should it become necessary for BellSouth to re-key Remote Site Locations or deactivate a card as a result of a lost Access Key(s) or for failure to return an Access Key(s), Local Line shall pay for all reasonable costs associated with the re-keying or deactivating the card.
- 5.10 Interference or Impairment. Notwithstanding any other provisions of this Attachment, Local Line shall not use any product or service provided under this Agreement, any other service related thereto or used in combination therewith, or place or use any equipment and facilities in any manner that 1) significantly degrades, interferes with or impairs service provided by BellSouth or by any other entity or any person's use of its telecommunications service; 2) endangers or damages the equipment, facilities or other property of BellSouth or of any other entity or person; 3) compromises the privacy of any communications; or 4) creates an unreasonable risk of injury or death to any individual or to the public. If BellSouth reasonably determines that any equipment or facilities of Local Line violates the provisions of this paragraph, BellSouth shall give written notice to Local Line, which notice shall direct Local Line to cure the violation within forty-eight (48) hours of Local Line's actual receipt of written notice or, at a

minimum, to commence curative measures within 24 hours and to exercise reasonable diligence to complete such measures as soon as possible thereafter. After receipt of the notice, the Parties agree to consult immediately and, if necessary, to inspect the arrangement.

- 5.10.1 Except in the case of the deployment of an advanced service which significantly degrades the performance of other advanced services or traditional voice band services, if Local Line fails to take curative action within forty-eight (48) hours or if the violation is of a character which poses an immediate and substantial threat of damage to property, injury or death to any person, or any other significant degradation, interference or impairment of BellSouth's or any other entity's service, then and only in that event BellSouth may take such action as it deems appropriate to correct the violation, including without limitation the interruption of electrical power to Local Line's equipment. BellSouth will endeavor, but is not required, to provide notice to Local Line prior to taking such action and shall have no liability to Local Line for any damages arising from such action, except to the extent that such action by BellSouth constitutes willful misconduct.
- 5.10.2 For purposes of this section, the term significantly degrade shall mean an action that noticeably impairs a service from a user's perspective. In the case of the deployment of an advanced service which significantly degrades the performance of other advanced services or traditional voice band services and Local Line fails to take curative action within forty-eight (48) hours then BellSouth will establish before the Commission that the technology deployment is causing the significant degradation. Any claims of network harm presented to Local Line or, if subsequently necessary, the Commission must be supported with specific and verifiable information. Where BellSouth demonstrates that a deployed technology is significantly degrading the performance of other advanced services or traditional voice band services, Local Line shall discontinue deployment of that technology and migrate its customers to technologies that will not significantly degrade the performance of other such services. Where the only degraded service itself is a known disturber, and the newly deployed technology satisfies at least one of the criteria for a presumption that is acceptable for deployment under Section 47 C.F.R. 51.230, the degraded service shall not prevail against the newly-deployed technology.
- 5.11 Personalty and its Removal. Facilities and equipment placed by Local Line in the Remote Collocation Space shall not become a part of the Remote Site Location, even if nailed, screwed or otherwise fastened to the Remote Collocation Space but shall retain their status as personalty and may be removed by Local Line at any time. Any damage caused to the Remote Collocation Space by Local Line's employees, agents or representatives shall be promptly repaired by Local Line at its expense.
- 5.11.1 If Local Line decides to remove equipment from its Remote Collocation Space and the removal requires no physical changes, BellSouth will bill Local Line an Administrative

Only Application Fee as set forth in Exhibit B for these changes. This nonrecurring fee will be billed on the date that BellSouth provides an Application Response.

- 5.12 Alterations. In no case shall Local Line or any person acting on behalf of Local Line make any rearrangement, modification, improvement, addition, or other alteration which could affect in any way space, power, HVAC, and/or safety considerations to the Remote Collocation Space or the BellSouth Remote Site Location without the written consent of BellSouth, which consent shall not be unreasonably withheld. The cost of any specialized alterations shall be paid by Local Line. Any such material rearrangement, modification, improvement, addition, or other alteration shall require an application and Application Fee. BellSouth will bill the nonrecurring fee on the date that BellSouth provides an Application Response.
- 5.13 Upkeep of Remote Collocation Space. Local Line shall be responsible for the general upkeep and cleaning of the Remote Collocation Space. Local Line shall be responsible for removing any Local Line debris from the Remote Collocation Space and from in and around the Remote Site Location on each visit.
6. **Ordering and Preparation of Remote Collocation Space**
- 6.1 Should any state or federal regulatory agency impose procedures or intervals applicable to Local Line and BellSouth that are different from procedures or intervals set forth in this Section, whether now in effect or that become effective after execution of this Agreement, those procedures or intervals shall supersede the requirements set forth herein for that jurisdiction for all applications submitted for the first time after the effective date thereof
- 6.2 Remote Site Application. When Local Line or Local Line's Guest(s) desires to install a bay/rack in a Remote Site Location, Local Line shall submit to BellSouth a Physical Expanded Interconnection Application Document ("Application"). The application is Bona Fide when it is complete and accurate, meaning that all required fields on the application are completed with the appropriate type of information. An application fee will apply which will be billed on the date that BellSouth provides an Application Response. The placement of an additional bay/rack at a later date will be treated in the same fashion and an application will be required. The installation of additional shelves/equipment, subject to the restrictions contained in Section 5.10, within an existing bay/rack does not require an application.
- 6.3 Availability of Space. Upon submission of an application, BellSouth will permit Local Line to physically collocate, pursuant to the terms of this Attachment, at any BellSouth Remote Site Location, unless BellSouth has determined that there is no space available due to space limitations or that collocation at the Remote Site Location is not practical for technical reasons. In the event space is not immediately available at a Remote Site Location, BellSouth reserves the right to make additional space available, in which case the conditions in Section 7 shall apply, or BellSouth may elect to deny space in accordance with this Section in which case virtual or adjacent

collocation options may be available. If the amount of space requested is not available, BellSouth will notify Local Line of the amount that is available.

6.4 Space Availability Notification.

6.4.1 Unless otherwise specified, BellSouth will respond to an application within ten (10) calendar days as to whether space is available or not available within a BellSouth Remote Site Location. BellSouth will also respond as to whether the application is Bona Fide and if it is not Bona Fide the items necessary to cause the application to become Bona Fide. If the amount of space requested is not available, BellSouth will notify Local Line of the amount of space that is available and no Application Fee shall apply. When BellSouth's response includes an amount of space less than that requested by Local Line or differently configured no application fee shall apply. If Local Line decides to accept the available space, Local Line must resubmit its application to reflect the actual space available prior to submitting a BFFO and an application fee will be billed.

6.4.2 BellSouth will respond to a Florida application within fifteen (15) calendar days as to whether space is available or not available within a BellSouth Remote Site Location. BellSouth will also respond as to whether the application is Bona Fide and if it is not Bona Fide the items necessary to cause the application to become Bona Fide. If a lesser amount of space than requested is available, BellSouth will provide an Application Response for the amount of space that is available and an Application Fee will be billed by BellSouth on the date that BellSouth provides an Application Response. When BellSouth's Application Response includes an amount of space less than that requested by Local Line or differently configured, if Local Line decides to accept the available space, Local Line must amend its application to reflect the actual space available prior to submitting a BFFO.

6.5 Denial of Application. If BellSouth notifies Local Line that no space is available ("Denial of Application"), BellSouth will not assess an Application Fee. After notifying Local Line that BellSouth has no available space in the requested Remote Site Location, BellSouth will allow Local Line, upon request, to tour the Remote Site Location within ten (10) calendar days of such Denial of Application. In order to schedule said tour within ten (10) calendar days, the request for a tour of the Remote Site Location must be received by BellSouth within five (5) calendar days of the Denial of Application.

6.6 Filing of Petition for Waiver. Upon Denial of Application BellSouth will timely file a petition with the Commission pursuant to 47 U.S.C. § 251(c)(6). BellSouth shall provide to the Commission any information requested by that Commission. Such information shall include which space, if any, BellSouth or any of BellSouth's affiliates have reserved for future use and a detailed description of the specific future uses for which the space has been reserved. Subject to an appropriate nondisclosure agreement or provision, BellSouth shall permit Local Line to inspect any plans or diagrams that BellSouth provides to the Commission.



- 6.7 Waiting List. On a first-come, first-served basis governed by the date of receipt of an application or Letter of Intent, BellSouth will maintain a waiting list of requesting carriers who have either received a Denial of Application or, where it is publicly known that the Remote Site Location is out of space, have submitted a Letter of Intent to collocate. BellSouth will notify the telecommunications carriers on the waiting list that can be accommodated by the amount of space that becomes available according to the position of the telecommunications carriers on said waiting list.
- 6.7.1 In Florida, on a first-come, first-served basis governed by the date of receipt of an application or Letter of Intent, BellSouth will maintain a waiting list of requesting carriers who have either received a Denial of Application or, where it is publicly known that the Remote Site Location is out of space, have submitted a Letter of Intent to collocate. Sixty (60) calendar days prior to space becoming available, if known, BellSouth will notify the Florida PSC and the telecommunications carriers on the waiting list by mail when space becomes available according to the position of the telecommunications carrier on said waiting list. If not known sixty (60) calendar days in advance, BellSouth shall notify the Florida PSC and the telecommunications carriers on the waiting list within two business days of the determination that space is available. A telecommunications carrier that, upon denial of physical collocation, requests virtual collocation shall be automatically placed on the waiting list.
- 6.7.2 When space becomes available, Local Line must submit an updated, complete, and correct application to BellSouth within thirty (30) calendar days of such notification. If Local Line has originally requested caged Remote Collocation Space and cageless Remote Collocation Space becomes available, Local Line may refuse such space and notify BellSouth in writing within that time that Local Line wants to maintain its place on the waiting list without accepting such space. Local Line may accept an amount of space less than its original request by submitting an application as set forth above, and upon request, may maintain its position on the waiting list for the remaining space that was initially requested. If Local Line does not submit such an application or notify BellSouth in writing as described above, BellSouth will offer such space to the next telecommunications carrier on the waiting list and remove Local Line from the waiting list. Upon request, BellSouth will advise Local Line as to its position on the list.
- 6.8 Public Notification. BellSouth will maintain on its Interconnection Services website a notification document that will indicate all Remote Site Locations that are without available space. BellSouth shall update such document within ten (10) calendar days of the date that BellSouth becomes aware that there is insufficient space to accommodate collocation at the Remote Site Location. BellSouth will also post a document on its Interconnection Services website that contains a general notice where space has become available in a Remote Site Location previously on the space exhaust list.
- 6.9 Application Response.

6.9.1 In Florida, within fifteen (15) calendar days of receipt of a Bona Fide application, when space has been determined to be available or when a lesser amount of space than that requested is available, then with respect to the space available, BellSouth will provide an Application Response including sufficient information to enable Local Line to place a Firm Order. The Application Response will include, at a minimum, the configuration of the space, the Cable Installation Fee, Cable Records Fee, and the space preparation fees, as described in Section 8. When Local Line submits ten (10) or more applications within ten (10) calendar days, the initial fifteen (15) calendar day response period will increase by ten (10) calendar days for every additional ten (10) applications or fraction thereof.

6.10 Application Modifications.

6.10.1 If a modification or revision is made to any information in the Bona Fide application prior to a BFFO, with the exception of modifications to Customer Information, Contact Information or Billing Contact Information, either at the request of Local Line or necessitated by technical considerations, said application shall be considered a new application and shall be handled as a new application with respect to response and provisioning intervals and BellSouth will charge Local Line a full application fee as set forth in Exhibit B. BellSouth will bill the nonrecurring fee on the date that BellSouth provides an Application Response.

6.10.2 Bona Fide Firm Order.

6.10.3 Local Line shall indicate its intent to proceed with equipment installation in a BellSouth Remote Site Location by submitting a Firm Order to BellSouth. The BFFO must be received by BellSouth no later than thirty (30) calendar days after BellSouth's Application Response to Local Line's Bona Fide application or the application will expire.

6.10.4 BellSouth will establish a firm order date based upon the date BellSouth is in receipt of a BFFO. BellSouth will acknowledge the receipt of Local Line's BFFO within seven (7) calendar days of receipt indicating that the BFFO has been received. A BellSouth response to a BFFO will include a Firm Order Confirmation containing the firm order date. No revisions will be made to a BFFO.

7. Construction and Provisioning

7.1 Construction and Provisioning Intervals.

7.1.1 In Florida, BellSouth will complete construction for collocation arrangements as soon as possible and within a maximum of ninety (90) calendar days from receipt of a BFFO or as agreed to by the Parties. For changes to Remote Collocation Space after initial space completion ("Augmentation"), BellSouth will complete construction for

collocation arrangements as soon as possible and within a maximum of forty-five (45) calendar days from receipt of a BFFO or as agreed to by the Parties. If BellSouth does not believe that construction will be completed within the relevant time frame and BellSouth and Local Line cannot agree upon a completion date, within forty-five (45) calendar days of receipt of the BFFO for an initial request, and within thirty (30) calendar days for Augmentations, BellSouth may seek an extension from the Florida Commission.

- 7.2 In the event BellSouth does not have space immediately available at a Remote Site Location, BellSouth may elect to make additional space available by, for example but not limited to, rearranging BellSouth facilities or constructing additional capacity. In such cases, the above intervals shall not apply and BellSouth will provision the Remote Collocation Space in a nondiscriminatory manner and at parity with BellSouth and will provide Local Line with the estimated completion date in its Response.
- 7.3 Joint Planning. Joint planning between BellSouth and Local Line will commence within a maximum of twenty (20) calendar days from BellSouth's receipt of a BFFO. BellSouth will provide the preliminary design of the Remote Collocation Space and the equipment configuration requirements as reflected in the Bona Fide application and affirmed in the BFFO. The Remote Collocation Space completion time period will be provided to Local Line during joint planning.
- 7.4 Permits. Each Party or its agents will diligently pursue filing for the permits required for the scope of work to be performed by that Party or its agents within ten (10) calendar days of the completion of finalized construction designs and specifications.
- 7.5 Acceptance Walkthrough. Local Line will schedule and complete an acceptance walkthrough of each Remote Collocation Space with BellSouth within fifteen (15) calendar days of BellSouth's notifying Local Line that the Remote Collocation Space is ready for occupancy. In the event that Local Line fails to complete an acceptance walkthrough within this fifteen (15) calendar day interval, the Remote Collocation Space shall be deemed accepted by Local Line on the Space Ready Date. BellSouth will correct any deviations to Local Line's original or jointly amended requirements within seven (7) calendar days after the walkthrough, unless the Parties jointly agree upon a different time frame.
- 7.6 Use of BellSouth Certified Supplier. Local Line shall select a supplier which has been approved by BellSouth to perform all engineering and installation work Local Line and Local Line's BellSouth Certified Supplier must follow and comply with all BellSouth requirements outlined in BellSouth's TR 73503, TR 73519, TR 73572, and TR 73564. In some cases, Local Line must select separate BellSouth Certified Suppliers for transmission equipment, switching equipment and power equipment. BellSouth shall provide Local Line with a list of BellSouth Certified Suppliers upon request. The BellSouth Certified Supplier(s) shall be responsible for installing Local Line's

equipment and components, extending power cabling to the BellSouth power distribution frame, performing operational tests after installation is complete, and notifying BellSouth's Outside Plant engineers and Local Line upon successful completion of installation. The BellSouth Certified Supplier shall bill Local Line directly for all work performed for Local Line pursuant to this Attachment, and BellSouth shall have no liability for nor responsibility to pay such charges imposed by the BellSouth Certified Supplier. BellSouth shall make available its supplier certification program to Local Line or any supplier proposed by Local Line and will not unreasonably withhold certification. All work performed by or for Local Line shall conform to generally accepted industry standards.

7.7 Alarm and Monitoring. BellSouth may place alarms in the Remote Site Location for the protection of BellSouth equipment and facilities. Local Line shall be responsible for placement, monitoring and removal of environmental and equipment alarms used to service Local Line's Remote Collocation Space. Upon request, BellSouth will provide Local Line with applicable tariffed service(s) to facilitate remote monitoring of collocated equipment by Local Line. Both Parties shall use best efforts to notify the other of any verified hazardous conditions known to that Party.

7.8 Virtual Remote Collocation Space Relocation. In the event physical Remote Collocation Space was previously denied at a Remote Site Location due to technical reasons or space limitations, and physical Remote Collocation Space has subsequently become available, Local Line may relocate its virtual Remote Collocation arrangements to physical Remote Collocation Space arrangements and pay the appropriate fees for physical Remote Collocation Space and for the rearrangement or reconfiguration of services terminated in the virtual Remote Collocation Space arrangement, as outlined in the appropriate BellSouth tariffs. In the event that BellSouth knows when additional space for physical Remote Collocation Space may become available at the location requested by Local Line, such information will be provided to Local Line in BellSouth's written denial of physical Remote Collocation Space. To the extent that (i) physical Remote Collocation Space becomes available to Local Line within one hundred eighty (180) calendar days of BellSouth's written denial of Local Line's request for physical collocation, (ii) BellSouth had knowledge that the space was going to become available, and (iii) Local Line was not informed in the written denial that physical Remote Collocation Space would become available within such one hundred eighty (180) calendar days, then Local Line may relocate its virtual Remote Collocation Space arrangement to a physical Remote Collocation Space arrangement and will receive a credit for any nonrecurring charges previously paid for such virtual Remote Collocation Space. Local Line must arrange with a BellSouth Certified Supplier for the relocation of equipment from its virtual Remote Collocation Space to its physical Remote Collocation Space and will bear the cost of such relocation.

7.9 Virtual to Physical Conversion (In-Place). Virtual collocation arrangements may be converted to "in-place" physical arrangements if the potential conversion meets the

following four criteria: 1) there is no change in the amount of equipment or the configuration of the equipment that was in the virtual collocation arrangement; 2) the conversion of the virtual collocation arrangement will not cause the equipment or the results of that conversion to be located in a space that BellSouth has reserved for its own future needs; 3) the converted arrangement does not limit BellSouth's ability to secure its own equipment and facilities due to the location of the virtual collocation arrangement; and 4) any changes to the arrangement can be accommodated by existing power, HVAC, and other requirements. **Unless otherwise specified, BellSouth will complete virtual to in-place physical collocation conversions within sixty (60) calendar days from receipt of the BFFO. BellSouth will bill Local Line an Administrative Only Application Fee as set forth in Exhibit B for these charges on the date that BellSouth provides an Application Response.**

7.10 **Cancellation.** If, at any time prior to space acceptance, Local Line cancels its order for the Remote Collocation Space(s) ("Cancellation"), BellSouth will bill the applicable nonrecurring rate for any and all work processes for which work has begun.

7.11 **Licenses.** Local Line, at its own expense, will be solely responsible for obtaining from governmental authorities, and any other appropriate agency, entity, or person, all rights, privileges, and licenses necessary or required to operate as a provider of telecommunications services to the public or to build-out, equip and occupy the Remote Collocation Space.

7.12 **Environmental Hazard Guidelines.** The Parties agree to utilize and adhere to the Environmental Hazard Guidelines identified in Exhibit A attached hereto.

## **8. Rates and Charges**

8.1 **Recurring Charges.** If Local Line has met the applicable fifteen (15) calendar day walkthrough interval(s) specified in Section 4, billing for recurring charges will begin upon the Space Acceptance Date. In the event that Local Line fails to complete an acceptance walkthrough within the applicable fifteen (15) calendar day interval(s), billing for recurring charges will commence on the Space Ready Date. If Local Line occupies the space prior to the Space Ready Date, the date Local Line occupies the space becomes the new Space Acceptance Date and billing for recurring charges begin on that date.

8.2 **Application Fee.** BellSouth shall assess an Application Fee via a service order, which shall be issued at the time BellSouth responds that space is available pursuant to Section 6.10 (Application Response). This nonrecurring fee will be billed by BellSouth on the date that BellSouth provides an Application Response.

8.3 **Rack/Bay Space.** The rack/bay space charge includes reasonable charges for air conditioning, ventilation and other allocated expenses associated with maintenance of the Remote Site Location, and includes amperage necessary to power Local Line's equipment. Local Line shall pay rack/bay space charges based upon the number of

racks/bays requested. BellSouth will assign Remote Collocation Space in conventional remote site rack/bay lineups where feasible.

- 8.4** Power. BellSouth shall make available -48 Volt (-48V) DC power for Local Line's Remote Collocation Space at a BellSouth Power Board or BellSouth Battery Distribution Fuse Bay (BDFB) at Local Line's option within the Remote Site Location. The charge for power shall be assessed as part of the recurring charge for rack/bay space. If the power requirements for Local Line's equipment exceeds the capacity available, then such power requirements shall be assessed on an individual case basis. BellSouth will revise recurring power charges to reflect a power upgrade upon notification of the completion of the upgrade by Local Line's BellSouth Certified Vendor. BellSouth will revise recurring power charges to reflect a power reduction upon BellSouth's receipt of the Power Reduction Form from Local Line certifying the completion of the power reduction, including the removal of the power cabling by Local Line's BellSouth Certified Supplier.
- 8.4.1** Adjacent Collocation Power. Charges for AC power will be assessed per breaker ampere per month. Rates include the provision of commercial and standby AC power, where available. When obtaining power from a BellSouth service panel, protection devices and power cables must be engineered (sized), and installed by Local Line's BellSouth Certified Supplier except that BellSouth shall engineer and install protection devices and power cables for Adjacent Collocation. Local Line's BellSouth Certified Supplier must also provide a copy of the engineering power specification prior to the equipment becoming operational. Charges for AC power shall be assessed pursuant to the rates specified in Exhibit B. AC power voltage and phase ratings shall be determined on a per location basis. At Local Line's option, Local Line may arrange for AC power in an Adjacent Collocation arrangement from a retail provider of electrical power.
- 8.5** Security Escort. A security escort will be required whenever Local Line or its approved agent desires access to the Remote Site Location after the one accompanied site visit allowed pursuant to Section 5 prior to completing BellSouth's Security Training requirements. Rates for a security escort are assessed according to the schedule appended hereto as Exhibit B beginning with the scheduled escort time. BellSouth will wait for one-half (1/2) hour after the scheduled time for such an escort and Local Line shall pay for such half-hour charges in the event Local Line fails to show up.
- 8.6** Other. If no rate is identified in the contract, the rate for the specific service or function will be negotiated by the Parties upon request by either Party.
- 9. Insurance**
- 9.1** Local Line shall, at its sole cost and expense, procure, maintain, and keep in force insurance as specified in this Section and underwritten by insurance companies

licensed to do business in the states applicable under this Agreement and having a Best's Insurance Rating of A-.

- 9.2 Local Line shall maintain the following specific coverage:
  - 9.2.1 Commercial General Liability coverage in the amount of ten million dollars (\$10,000,000.00) or a combination of Commercial General Liability and Excess/Umbrella coverage totaling not less than ten million dollars (\$10,000,000.00). BellSouth shall be named as an Additional Insured on the Commercial General Liability policy as specified herein.
  - 9.2.2 Statutory Workers Compensation coverage and Employers Liability coverage in the amount of one hundred thousand dollars (\$100,000.00) each accident, one hundred thousand dollars (\$100,000.00) each employee by disease, and five hundred thousand dollars (\$500,000.00) policy limit by disease.
  - 9.2.3 All Risk Property coverage on a full replacement cost basis insuring all of Local Line's real and personal property situated on or within BellSouth's Remote Site Location.
  - 9.2.4 Local Line may elect to purchase business interruption and contingent business interruption insurance, having been advised that BellSouth assumes no liability for loss of profit or revenues should an interruption of service occur.
- 9.3 The limits set forth in Section 9.2 above may be increased by BellSouth from time to time during the term of this Agreement upon thirty (30) calendar days notice to Local Line to at least such minimum limits as shall then be customary with respect to comparable occupancy of BellSouth structures.
- 9.4 All policies purchased by Local Line shall be deemed to be primary and not contributing to or in excess of any similar coverage purchased by BellSouth. All insurance must be in effect on or before the date equipment is delivered to BellSouth's Remote Site Location and shall remain in effect for the term of this Attachment or until all of Local Line's property has been removed from BellSouth's Remote Site Location, whichever period is longer. If Local Line fails to maintain required coverage, BellSouth may pay the premiums thereon and seek reimbursement of same from Local Line.
- 9.5 Local Line shall submit certificates of insurance reflecting the coverage required pursuant to this Section a minimum of ten (10) business days prior to the commencement of any work in the Remote Collocation Space. Failure to meet this interval may result in construction and equipment installation delays. Local Line shall arrange for BellSouth to receive thirty (30) business days' advance notice of cancellation from Local Line's insurance company. Local Line shall forward a certificate of insurance and notice of cancellation/non-renewal to BellSouth at the following address:

BellSouth Telecommunications, Inc.  
Attn.: Risk Management Coordinator  
17H53 BellSouth Center  
675 W. Peachtree Street  
Atlanta, Georgia 30375

- 9.6 Local Line must conform to recommendations made by BellSouth's fire insurance company to the extent BellSouth has agreed to, or shall hereafter agree to, such recommendations.
- 9.7 Self-Insurance. If Local Line's net worth exceeds five hundred million dollars (\$500,000,000), Local Line may elect to request self-insurance status in lieu of obtaining any of the insurance required in Sections 9.2.1 and 9.2.2. Local Line shall provide audited financial statements to BellSouth thirty (30) calendar days prior to the commencement of any work in the Remote Collocation Space. BellSouth shall then review such audited financial statements and respond in writing to Local Line in the event that self-insurance status is not granted to Local Line. If BellSouth approves Local Line for self-insurance, Local Line shall annually furnish to BellSouth, and keep current, evidence of such net worth that is attested to by one of Local Line's corporate officers. The ability to self-insure shall continue so long as Local Line meets all of the requirements of this Section. If Local Line subsequently no longer satisfies this Section, Local Line is required to purchase insurance as indicated by Sections 9.2.1 and Section 9.2.2.
- 9.8 The net worth requirements set forth in Section 9.7 may be increased by BellSouth from time to time during the term of this Attachment upon thirty (30) calendar days' notice to Local Line to at least such minimum limits as shall then be customary with respect to comparable occupancy of BellSouth structures.
- 9.9 Failure to comply with the provisions of this Section will be deemed a material breach of this Attachment.

**10. Mechanics Liens**

- 10.1 If any mechanics lien or other liens shall be filed against property of either Party (BellSouth or Local Line), or any improvement thereon by reason of or arising out of any labor or materials furnished or alleged to have been furnished or to be furnished to or for the other Party or by reason of any changes, or additions to said property made at the request or under the direction of the other Party, the other Party directing or requesting those changes shall, within thirty (30) business days after receipt of written notice from the Party against whose property said lien has been filed, either pay such lien or cause the same to be bonded off the affected property in the manner provided by law. The Party causing said lien to be placed against the property of the other shall also defend, at its sole cost and expense, on behalf of the other, any action, suit or



proceeding which may be brought for the enforcement of such liens and shall pay any damage and discharge any judgment entered thereon.

**11. Inspections**

11.1 BellSouth may conduct an inspection of Local Line's equipment and facilities in the Remote Collocation Space(s) prior to the activation of facilities between Local Line's equipment and equipment of BellSouth. BellSouth may conduct an inspection if Local Line adds equipment and may otherwise conduct routine inspections at reasonable intervals mutually agreed upon by the Parties. BellSouth shall provide Local Line with a minimum of forty-eight (48) hours or two (2) business days, whichever is greater, advance notice of all such inspections. All costs of such inspection shall be borne by BellSouth.

**12. Security and Safety Requirements**

12.1 Unless otherwise specified, Local Line will be required, at its own expense, to conduct a statewide investigation of criminal history records for each Local Line employee hired in the past five years being considered for work on the BellSouth Remote Site Location, for the states/counties where the Local Line employee has worked and lived for the past five years. Where state law does not permit statewide collection or reporting, an investigation of the applicable counties is acceptable. Local Line shall not be required to perform this investigation if an affiliated company of Local Line has performed an investigation of the Local Line employee seeking access, if such investigation meets the criteria set forth above. This requirement will not apply if Local Line has performed a pre-employment statewide investigation of criminal history records of the Local Line employee for the states/counties where the Local Line employee has worked and lived for the past five years or, where state law does not permit a statewide investigation, an investigation of the applicable counties.

12.2 Local Line will be required to administer to their personnel assigned to the BellSouth Premises security training either provided by BellSouth, or meeting criteria defined by BellSouth.

12.3 Local Line shall provide its employees and agents with picture identification, which must be worn, and visible at all times while in the Remote Collocation Space or other areas in or around the Remote Site Location. The photo Identification card shall bear, at a minimum, the employee's name and photo, and Local Line's name. BellSouth reserves the right to remove from its Remote Site Location any employee of Local Line not possessing identification issued by Local Line or who have violated any of BellSouth's policies as outlined in the CLEC Security Training documents. Local Line shall hold BellSouth harmless for any damages resulting from such removal of its personnel from BellSouth Remote Site Location. Local Line shall be solely responsible for ensuring that any Guest(s) of Local Line is in compliance with all subsections of this Section.

- 12.4 Local Line shall not assign to the BellSouth Remote Site Location any personnel with records of felony criminal convictions. Local Line shall not assign to the BellSouth Remote Site Location any personnel with records of misdemeanor convictions, except for misdemeanor traffic violations, without advising BellSouth of the nature and gravity of the offense(s). BellSouth reserves the right to refuse access to any Local Line personnel who have been identified to have misdemeanor criminal convictions. Notwithstanding the foregoing, in the event that Local Line chooses not to advise BellSouth of the nature and gravity of any misdemeanor conviction, Local Line may, in the alternative, certify to BellSouth that it shall not assign to the BellSouth Remote Site Location any personnel with records of misdemeanor convictions (other than misdemeanor traffic violations).
- 12.4.1 Local Line shall not knowingly assign to the BellSouth Remote Site Location any individual who was a former employee of BellSouth and whose employment with BellSouth was terminated for a criminal offense whether or not BellSouth sought prosecution of the individual for the criminal offense.
- 12.4.2 Local Line shall not knowingly assign to the BellSouth Remote Site Location any individual who was a former supplier of BellSouth and whose access to a BellSouth Remote Site Location was revoked due to commission of a criminal offense whether or not BellSouth sought prosecution of the individual for the criminal offense.
- 12.5 For each Local Line employee or agent hired by Local Line within five years of being considered for work on the BellSouth Remote Site Location, who requires access to a BellSouth Remote Site Location pursuant to this Attachment, Local Line shall furnish BellSouth, prior to an employee gaining such access, a certification that the aforementioned background check and security training were completed. The certification will contain a statement that no felony convictions were found and certifying that the security training was completed by the employee. If the employee's criminal history includes misdemeanor convictions, Local Line will disclose the nature of the convictions to BellSouth at that time. In the alternative, Local Line may certify to BellSouth that it shall not assign to the BellSouth Remote Site Location any personnel with records of misdemeanor convictions other than misdemeanor traffic violations.
- 12.5.1 For all other Local Line employees requiring access to a BellSouth Remote Site Location pursuant to this Attachment, Local Line shall furnish BellSouth, prior to an employee gaining such access, a certification that the employee is not subject to the requirements of Section 12.5 above and that security training was completed by the employee.
- 12.6 At BellSouth's request, Local Line shall promptly remove from BellSouth's Remote Site Location any employee of Local Line BellSouth does not wish to grant access to its Remote Site Location 1) pursuant to any investigation conducted by BellSouth or 2) prior to the initiation of an investigation if an employee of Local Line is found

interfering with the property or personnel of BellSouth or another collocated telecommunications carrier, provided that an investigation shall promptly be commenced by BellSouth.

- 12.7 **Security Violations.** BellSouth reserves the right to interview Local Line's employees, agents, or suppliers in the event of wrongdoing in or around BellSouth's property or involving BellSouth's or another collocated telecommunications carrier's property or personnel, provided that BellSouth shall provide reasonable notice to Local Line's Security representative of such interview. Local Line and its suppliers shall reasonably cooperate with BellSouth's investigation into allegations of wrongdoing or criminal conduct committed by, witnessed by, or involving Local Line's employees, agents, or suppliers. Additionally, BellSouth reserves the right to bill Local Line for all reasonable costs associated with investigations involving its employees, agents, or suppliers if it is established and mutually agreed in good faith that Local Line's employees, agents, or suppliers are responsible for the alleged act. BellSouth shall bill Local Line for BellSouth property, which is stolen or damaged where an investigation determines the culpability of Local Line's employees, agents, or suppliers and where Local Line agrees, in good faith, with the results of such investigation. Local Line shall notify BellSouth in writing immediately in the event that the Local Line discovers one of its employees already working on the BellSouth Remote Site Location is a possible security risk. Upon request of the other Party, the Party who is the employer shall discipline consistent with its employment practices, up to and including removal from BellSouth's Remote Site Location, any employee found to have violated the security and safety requirements of this section. Local Line shall hold BellSouth harmless for any damages resulting from such removal of its personnel from BellSouth's Remote Site Location.
- 12.8 **Use of Supplies.** Unauthorized use of telecommunications equipment or supplies by either Party, whether or not used routinely to provide telephone service (e.g. plug-in cards,) will be strictly prohibited and handled appropriately. Costs associated with such unauthorized use may be charged to the offending Party, as may be all associated investigative costs.
- 12.9 **Use of Official Lines.** Except for non-toll calls necessary in the performance of their work, neither Party shall use the telephones of the other Party on the BellSouth Remote Site Location. Charges for unauthorized telephone calls may be charged to the offending Party, as may be all associated investigative costs.
- 12.10 **Accountability.** Full compliance with the Security requirements of this Section shall in no way limit the accountability of either Party to the other for the improper actions of its employees.
13. **Destruction of Remote Collocation Space**
- 13.1 In the event a Remote Collocation Space is wholly or partially damaged by fire, windstorm, tornado, flood or by similar causes to such an extent as to be rendered

wholly unsuitable for Local Line's permitted use hereunder, then either Party may elect within ten (10) calendar days after such damage, to terminate this Attachment with respect to the affected Remote Collocation Space, and if either Party shall so elect, by giving the other written notice of termination, both Parties shall stand released of and from further liability under the terms hereof with respect to such Remote Collocation Space. If the Remote Collocation Space shall suffer only minor damage and shall not be rendered wholly unsuitable for Local Line's permitted use, or is damaged and the option to terminate is not exercised by either Party, BellSouth covenants and agrees to proceed promptly without expense to Local Line, except for improvements not to the property of BellSouth, to repair the damage. BellSouth shall have a reasonable time within which to rebuild or make any repairs, and such rebuilding and repairing shall be subject to delays caused by storms, shortages of labor and materials, government regulations, strikes, walkouts, and causes beyond the control of BellSouth, which causes shall not be construed as limiting factors, but as exemplary only. Local Line may, at its own expense, accelerate the rebuild of its Remote Collocation Space and equipment provided however that a BellSouth Certified Supplier is used and the necessary space preparation has been completed. Rebuild of equipment must be performed by a BellSouth Certified Vendor. If Local Line's acceleration of the project increases the cost of the project, then those additional charges will be incurred by Local Line. Where allowed and where practical, Local Line may erect a temporary facility while BellSouth rebuilds or makes repairs. In all cases where the Remote Collocation Space shall be rebuilt or repaired, Local Line shall be entitled to an equitable abatement of rent and other charges, depending upon the unsuitability of the Remote Collocation Space for Local Line's permitted use, until such Remote Collocation Space is fully repaired and restored and Local Line's equipment installed therein (but in no event later than thirty (30) calendar days after the Remote Collocation Space is fully repaired and restored). Where Local Line has placed a Remote Site Adjacent Arrangement pursuant to Section 3.4, Local Line shall have the sole responsibility to repair or replace said Remote Site Adjacent Arrangement provided herein. Pursuant to this Section, BellSouth will restore the associated services to the Remote Site Adjacent Arrangement.

**14. Eminent Domain**

- 14.1 If the whole of a Remote Collocation Space or Remote Site Adjacent Arrangement shall be taken by any public authority under the power of eminent domain, then this Attachment shall terminate with respect to such Remote Collocation Space or Remote Site Adjacent Arrangement as of the day possession shall be taken by such public authority and rent and other charges for the Remote Collocation Space or Remote Site Adjacent Arrangement shall be paid up to that day with proportionate refund by BellSouth of such rent and charges as may have been paid in advance for a period subsequent to the date of the taking. If any part of the Remote Collocation Space or Remote Site Adjacent Arrangement shall be taken under eminent domain, BellSouth and Local Line shall each have the right to terminate this Attachment with respect to such Remote Collocation Space or Remote Site Adjacent Arrangement and declare the

same null and void, by written notice of such intention to the other Party within ten (10) calendar days after such taking.

**15. Nonexclusivity**

15.1 Local Line understands that this Attachment is not exclusive and that BellSouth may enter into similar agreements with other Parties. Assignment of space pursuant to all such agreements shall be determined by space availability and made on a first come, first served basis.

## ENVIRONMENTAL AND SAFETY PRINCIPLES

The following principles provide basic guidance on environmental and safety issues when applying for and establishing Physical Collocation arrangements.

### 1. GENERAL PRINCIPLES

- 1.1 Compliance with Applicable Law. BellSouth and Local Line agree to comply with applicable federal, state, and local environmental and safety laws and regulations including U.S. Environmental Protection Agency (USEPA) regulations issued under the Clean Air Act (CAA), Clean Water Act (CWA), Resource Conservation and Recovery Act (RCRA), Comprehensive Environmental Response, Compensation and Liability Act (CERCLA), Superfund Amendments and Reauthorization Act (SARA), the Toxic Substances Control Act (TSCA), and OSHA regulations issued under the Occupational Safety and Health Act of 1970, as amended and NFPA and National Electrical Codes (NEC) and the NESC ("Applicable Laws"). Each Party shall notify the other if compliance inspections are conducted by regulatory agencies and/or citations are issued that relate to any aspect of this Attachment.
- 1.2 Notice. BellSouth and Local Line shall provide notice to the other, including Material Safety Data Sheets (MSDSs), of known and recognized physical hazards or Hazardous Chemicals existing on site or brought on site. A Hazardous Chemical inventory list is posted on an OSHA Poster and updated annually at each Central Office. This Poster is normally located near the front entrance of the building or in the lounge area. Each Party is required to provide specific notice for known potential Imminent Danger conditions. Local Line should contact 1-800-743-6737 for any BellSouth MSDS required.
- 1.3 Practices/Procedures. BellSouth may make available additional environmental control procedures for Local Line to follow when working at a BellSouth Remote Site Location (See Section 2, below). These practices/procedures will represent the regular work practices required to be followed by the employees and suppliers of BellSouth for environmental protection. Local Line will require its suppliers, agents and others accessing the BellSouth Remote Site Location to comply with these practices. Section 2 lists the Environmental categories where BST practices should be followed by Local Line when operating in the BellSouth Remote Site Location.
- 1.4 Environmental and Safety Inspections. BellSouth reserves the right to inspect the Local Line space with proper notification. BellSouth reserves the right to stop any Local Line work operation that imposes Imminent Danger to the environment, employees or other persons in the area or Remote Site Location.
- 1.5 Hazardous Materials Brought On Site. Any hazardous materials brought into, used, stored or abandoned at the BellSouth Remote Site Location by Local Line are owned by Local Line. Local Line will indemnify BellSouth for claims, lawsuits or damages to persons or property caused by these materials. Without prior written BellSouth approval, no substantial new safety or environmental hazards can be created by Local Line or different hazardous materials used by Local Line at the BellSouth Remote Site Location. Local Line must demonstrate adequate emergency response capabilities for its materials used or remaining at the BellSouth Remote Site Location.

- 1.6 Spills and Releases. When contamination is discovered at a BellSouth Remote Site Location, either Party discovering the condition must notify the other Party. All Spills or Releases of regulated materials will immediately be reported by Local Line to BellSouth.
- 1.7 Coordinated Environmental Plans and Permits. BellSouth and Local Line will coordinate plans, permits or information required to be submitted to government agencies, such as emergency response plans, spill prevention control and countermeasures (SPCC) plans and community reporting. If fees are associated with filing, BellSouth and Local Line will develop a cost sharing procedure. If BellSouth's permit or EPA identification number must be used, Local Line must comply with all of BellSouth's permit conditions and environmental processes, including environmental "best management practices (BMP)" (see Section 2, below) and/or selection of BST disposition vendors and disposal sites.
- 1.8 Environmental and Safety Indemnification. BellSouth and Local Line shall indemnify, defend and hold harmless the other Party from and against any claims (including, without limitation, third-party claims for personal injury or death or real or personal property damage), judgments, damages, (including direct and indirect damages, and punitive damages), penalties, fines, forfeitures, costs, liabilities, interest and losses arising in connection with the violation or alleged violation of any Applicable Law or contractual obligation or the presence or alleged presence of contamination arising out of the acts or omissions of the indemnifying Party, its agents, suppliers, or employees concerning its operations at the Remote Site Location.

**2. CATEGORIES FOR CONSIDERATION OF ENVIRONMENTAL ISSUES**

- 2.1 When performing functions that fall under the following Environmental categories on BellSouth's Remote Site Location, Local Line agrees to comply with the applicable sections of the current issue of BellSouth's Environmental and Safety Methods and Procedures (M&Ps), incorporated herein by this reference. Local Line further agrees to cooperate with BellSouth to ensure that Local Line's employees, agents, and/or suppliers are knowledgeable of and satisfy those provisions of BellSouth's Environmental M&Ps which apply to the specific Environmental function being performed by Local Line, its employees, agents and/or suppliers.
- 2.1.1 The most current version of reference documentation must be requested from Local Line's BellSouth Account Team Collocation Coordinator (ATCC) Representative.

ENVIRONMENTAL CATEGORIES	ENVIRONMENTAL ISSUES	ADDRESSED BY THE FOLLOWING DOCUMENTATION
Disposal of hazardous material or other regulated material (e.g., batteries, fluorescent tubes, solvents & cleaning materials)	Compliance with all applicable local, state, & federal laws and regulations  Pollution liability insurance	<ul style="list-style-type: none"> <li>• Std T&amp;C 450</li> <li>• Fact Sheet Series 17000</li>   <li>• Std T&amp;C 660-3</li>   <li>• Approved Environmental Vendor List (Contact ATCC</li> </ul>

	EVET approval of supplier	Representative)
Emergency response	Hazmat/waste release/spill fire safety emergency	<ul style="list-style-type: none"> <li>• Fact Sheet Series 1700</li> <li>• Building Emergency Operations Plan (EOP) (specific to and located on Remote Site Location)</li> </ul>
Contract labor/outsourcing for services with environmental implications to be performed on BellSouth Remote Site Location (e.g., disposition of hazardous material/waste; maintenance of storage tanks)	<p>Compliance with all applicable local, state, &amp; federal laws and regulations</p> <p>Performance of services in accordance with BST's environmental M&amp;Ps</p> <p>Insurance</p>	<ul style="list-style-type: none"> <li>• Std T&amp;C 450</li> <li>• Std T&amp;C 450-B (Contact ATCC Representative for copy of appropriate E/S M&amp;Ps.)</li> <li>• Std T&amp;C 660</li> </ul>
Transportation of hazardous material	<p>Compliance with all applicable local, state, &amp; federal laws and regulations</p> <p>Pollution liability insurance</p> <p>EVET approval of supplier</p>	<ul style="list-style-type: none"> <li>• Std T&amp;C 450</li> <li>• Fact Sheet Series 17000</li> <li>• Std T&amp;C 660-3</li> <li>• Approved Environmental Vendor List (Contact ATCC Representative)</li> </ul>
Maintenance/operations work which may produce a waste  Other maintenance work	<p>Compliance with all applicable local, state, &amp; federal laws and regulations</p> <p>Protection of BST employees and equipment</p>	<ul style="list-style-type: none"> <li>• Std T&amp;C 450</li> <li>• 29CFR 1910.147 (OSHA Standard)</li> <li>• 29CFR 1910 Subpart O (OSHA Standard)</li> </ul>
Janitorial services	<p>All waste removal and disposal must conform to all applicable federal, state and local regulations</p> <p>All Hazardous Material and Waste</p> <p>Asbestos notification and protection of employees and equipment</p>	<ul style="list-style-type: none"> <li>• -Procurement Manager (CRES Related Matters)-BST Supply Chain Services</li> <li>• Fact Sheet Series 17000</li> <li>• GU-BTEN-001BT, Chapter 3</li> <li>• BSP 010-170-001BS (Hazcom)</li> </ul>



<p>Manhole cleaning</p>	<p>Compliance with all applicable local, state, &amp; federal laws and regulations</p> <p>Pollution liability insurance</p> <p>EVET approval of supplier</p>	<ul style="list-style-type: none"> <li>• Std T&amp;C 450</li> <li>• Fact Sheet 14050</li> <li>• BSP 620-145-011PR Issue A, August 1996</li> <li>• Std T&amp;C 660-3</li> <li>• Approved Environmental Vendor List (Contact ATCC Representative)</li> </ul>
<p>Removing or disturbing building materials that may contain asbestos</p>	<p>Asbestos work practices</p>	<ul style="list-style-type: none"> <li>• GU-BTEN-001BT, Chapter 3</li> </ul> <p>For questions regarding removing or disturbing materials that contain asbestos, call the BellSouth Building Service Center: AL, MS, TN, KY &amp; LA (local area code) 557-6194 FL, GA, NC &amp; SC (local area code) 780-2740</p>

### 3. DEFINITIONS

Generator. Under RCRA, the person whose act produces a Hazardous Waste, as defined in 40 CFR 261, or whose act first causes a Hazardous Waste to become subject to regulation. The Generator is legally responsible for the proper management and disposal of Hazardous Wastes in accordance with regulations.

Hazardous Chemical. As defined in the U.S. Occupational Safety and Health (OSHA) hazard communication standard (29 CFR 1910.1200), any chemical which is a health hazard or physical hazard.

Hazardous Waste. As defined in section 1004 of RCRA.

Imminent Danger. Any conditions or practices at a remote site location which are such that a danger exists which could reasonably be expected to cause immediate death or serious harm to people or immediate significant damage to the environment or natural resources.

Spill or Release. As defined in Section 101 of CERCLA.

### 4. ACRONYMS

ATCC. – Account Team Collocation Coordinator

BST – BellSouth Telecommunications

CRES – Corporate Real Estate and Services (formerly PS&M)

DEC/LDEC - Department Environmental Coordinator/Local Department Environmental Coordinator

E/S – Environmental/Safety

EVET - Environmental Vendor Evaluation Team

GU-BTEN-001BT - BellSouth Environmental Methods and Procedures

NESC - National Electrical Safety Codes

P&SM - Property & Services Management

Std T&C - Standard Terms & Conditions

COLLOCATION - Florida										Attachment: 4		Exhibit: B			
CATEGORY	RATE ELEMENTS	Interi	Zone	BCS	USOC	RATES (\$)				Svc Order Submitted Elec per LSR	Svc Order Submitted Manually per LSR	Incremental Charge - Manual Svc Order vs. Electronic-1st	Incremental Charge - Manual Svc Order vs. Electronic-Add'l	Incremental Charge - Manual Svc Order vs. Electronic-Disc 1st	Incremental Charge - Manual Svc Order vs. Electronic-Disc Add'l
						Rec	Nonrecurring		Nonrecurring Disconnect						
							First	Add'l	First	Add'l					
<b>PHYSICAL COLLOCATION</b>															
	Physical Collocation 2-Wire Cross Connect, Exchange Port 2-Wire Analog - Res			UEPSR	PE1R2	0.0276	8.22	7.22							
	Physical Collocation 2-Wire Cross Connect, Exchange Port 2-Wire Line Side PBX Trunk - Bus			UEPSP	PE1R2	0.0276	8.22	7.22							
	Physical Collocation 2-Wire Cross Connect, Exchange Port 2-Wire Voice Grade PBX Trunk - Res			UEPSE	PE1R2	0.0276	8.22	7.22							
	Physical Collocation 2-Wire Cross Connect, Exchange Port 2-Wire Analog - Bus			UEPSB	PE1R2	0.0276	8.22	7.22							
	Physical Collocation 2-Wire Cross Connect, Exchange Port 2-Wire ISDN			UEPSX	PE1R2	0.0276	8.22	7.22							
	Physical Collocation 2-Wire Cross Connect, Exchange Port 2-Wire ISDN			UEPTX	PE1R2	0.0276	8.22	7.22							
	Physical Collocation 4-Wire Cross Connect, Exchange Port 4-Wire ISDN DS1			UEPEX	PE1R4	0.0552	8.42	7.36							
<b>PHYSICAL COLLOCATION</b>															
	Physical Collocation - Initial Application Fee			CLO	PE1BA		2,597.00								
	Physical Collocation - Subsequent Application Fee			CLO	PE1CA		2,236.00								
	Physical Collocation Administrative Only - Application Fee			CLO	PE1BL		742.00								
	Physical Collocation - Space Preparation - Firm Order Processing			CLO	PE1SJ		288.93								
	Physical Collocation - Space Preparation - C.O. Modification per square ft.			CLO	PE1SK		2.38								
	Physical Collocation - Space Preparation - Common Systems Modifications-Caged, per cage			CLO	PE1SM		92.55								
	Physical Collocation - Cable Installation, Pricing, non-recurring charge, per Entrance Cable			CLO	PE1BD		7.86		1,750.00	45.16					
	Physical Collocation - Floor Space, per sq feet			CLO	PE1PJ										
	Physical Collocation - Cable Support Structure, per Entrance Cable			CLO	PE1PM		18.95								
	Physical Collocation - Power, -48V DC Power - per Fused Amp			CLO	PE1PL		7.80								
	Physical Collocation - Power Reconfiguration Only, Application Fee			CLO	PE1PR		399.43								
	Physical Collocation - Power, 120V AC Power, Single Phase, per Breaker Amp			CLO	PE1FB		5.38								
	Physical Collocation - Power, 240V AC Power, Single Phase, per Breaker Amp			CLO	PE1FD		10.77								
	Physical Collocation - Power, 120V AC Power, Three Phase, per Breaker Amp			CLO	PE1FE		19.15								
	Physical Collocation - Power, 277V AC Power, Three Phase, per Breaker Amp			CLO	PE1FG		37.30								
	Physical Collocation - 2-wire cross-connect, loop, provisioning			UEANL, UEO, UNLDX, UNCNX, UEA, UCL, UAL, UHL, UDC, UDN, UNCWX	PE1P2	0.0276	8.22	7.22	5.74	4.58					
	Physical Collocation - 4-wire cross-connect, loop, provisioning			UEA, UHL, UNCWX, UNCDX, UCL, UDL	PE1P4	0.0552	8.42	7.36	5.90	4.66					
	Physical Collocation -DS1 Cross-Connect for Physical Collocation, provisioning			WDS1L, WDS1S, UXTD1, ULDD1, USLEL, UNLD1, UEPEX, UEPDX, USL, ULC, U1TD1, UNC1X	PE1P1	1.32	27.77	15.52	5.93	4.77					

COLLOCATION - Florida

CATEGORY	RATE ELEMENTS	Interm	Zone	BCS	USOC	RATES (\$)	Svc Order Submitted Elec per LSR	Svc Order Submitted Manually per LSR	Attachment: 4		Exhibit: B							
									Incremental Charge - Manual Svc Order vs. Electronic-1st	Incremental Charge - Manual Svc Order vs. Electronic-Add'l	Incremental Charge - Manual Svc Order vs. Electronic-Disc 1st	Incremental Charge - Manual Svc Order vs. Electronic-Disc Add'l						
									Rec	Nonrecurring		Nonrecurring Disconnect		OSS Rates (\$)				
	First	Add'l	First	Add'l	SOMEc	SOMAN	SOMAN	SOMAN	SOMAN	SOMAN	SOMAN							
	Physical Collocation - DS3 Cross-Connect, provisioning			UE3,U1TD3, UXTD3, UXTS1, UNCSX, UNCSX, ULDD3, U1TS1,ULDS1, UNLD3	PE1P3	16.81	25.48	14.05	7.77	5.01								
	Physical Collocation - 2-Fiber Cross-Connect			CLO, ULDO3, ULD12, ULD48, U1TO3, U1T12, U1T48, UDLO3, UDL12, UDF	PE1F2	3.34	41.94	30.52	13.91	11.16								
	Physical Collocation - 4-Fiber Cross-Connect			ULDO3, ULD12, ULD48, U1TO3, U1T12, U1T48, UDLO3, UDL12, UDF	PE1F4	5.92	51.30	39.87	18.29	15.54								
	Physical Collocation - Space enclosure, welded wire, first 100 square feet			CLO	PE1BW	189.45												
	Physical Collocation - Space enclosure, welded wire, each additional 50 square feet			CLO	PE1CW	18.58												
	Physical Collocation - Security Access System - Security System per Central Office			CLO	PE1AY	0.0105												
	Physical Collocation -Security Access System - New Card Activation, per Card Activation (First), per State			CLO	PE1A1	0.0577	55.80											
	Physical Collocation-Security Access System-Administrative Change, existing Access Card, per Request, per State, per Card			CLO	PE1AA		15.65											
	Physical Collocation - Security Access System - Replace Lost or Stolen Card, per Card			CLO	PE1AR		45.75											
	Physical Collocation - Security Access - Initial Key, per Key			CLO	PE1AK		26.30											
	Physical Collocation - Security Access - Key, Replace Lost or Stolen Key, per Key			CLO	PE1AL		26.30											
	Physical Collocation - Space Availability Report, per Central Office Requested			CLO	PE1SR		2,159.00											
	Physical Collocation - CFA Information Resend Request, per premises, per request			CLO	PE1C9		77.54											
	Physical Collocation - Cable Records, per request			CLO	PE1CR		1,525.00	980.22	267.08									
	Physical Collocation, Cable Records, VG/DS0 Cable, per cable record (maximum 3600 records)			CLO	PE1CD		656.50		379.78									
	Physical Collocation, Cable Records, VG/DS0 Cable, per each 100 pair			CLO	PE1CO		9.66		11.84									
	Physical Collocation, Cable Records, DS1, per T1 TIE			CLO	PE1C1		4.52		5.54									
	Physical Collocation, Cable Records, DS3, per T3 TIE			CLO	PE1C3		15.82		19.40									
	Physical Collocation - Cable Records, Fiber Cable, per cable record (maximum 99 records)			CLO	PE1CB		169.67		154.89									
	Physical Collocation - Security Escort for Basic Time - normally scheduled work, per half hour			CLO	PE1BT		16.52	10.83										
	Physical Collocation - Security Escort for Overtime - outside of normally scheduled working hours on a scheduled work day, per half hour			CLO	PE1OT		21.92	14.19										
	Physical Collocation - Security Escort for Premium Time - outside of scheduled work day, per half hour			CLO	PE1PT		27.31	17.55										
	Physical Collocation - Virtual to Physical Collocation Relocation, per Voice Grade Circuit			CLO	PE1BV		33.00											
	Physical Collocation - Virtual to Physical Collocation Relocation, per DSO Circuit			CLO	PE1BO		33.00											
	Physical Collocation - Virtual to Physical Collocation Relocation, per DS1 Circuit			CLO	PE1B1		52.00											

**COLLOCATION - Florida**

CATEGORY	RATE ELEMENTS	Interim	Zone	BCS	USOC	RATES (\$)	Svc Order Submitted Elec per LSR	Svc Order Submitted Manually per LSR	Attachment: 4		Exhibit: B								
									Incremental Charge - Manual Svc Order vs. Electronic-1st	Incremental Charge - Manual Svc Order vs. Electronic-Add'l	Incremental Charge - Manual Svc Order vs. Electronic-Disc 1st	Incremental Charge - Manual Svc Order vs. Electronic-Disc Add'l							
									Rec	Nonrecurring		Nonrecurring Disconnect		OSS Rates (\$)					
		First	Add'l	First	Add'l	SOME C	SOMAN	SOMAN	SOMAN	SOMAN	SOMAN								
	Physical Collocation - Virtual to Physical Collocation Relocation, per DS3 Circuit	I		CLO	PE1B3	52.00													
	Physical Collocation - Virtual to Physical Collocation In-Place, Per Voice Grade Circuit	I		CLO	PE1BR	23.00													
	Physical Collocation Virtual to Physical Collocation In-Place, Per DSO Circuit	I		CLO	PE1BP	23.00													
	Physical Collocation - Virtual to Physical Collocation In-Place, Per DS1 Circuit	I		CLO	PE1BS	33.00													
	Physical Collocation - Virtual to Physical Collocation In-Place, per DS3 Circuit	I		CLO	PE1BE	37.00													
	Physical Collocation - Virtual to Physical Collocation In-Place/Relocation, space cable facilities assigned to Collocation Space, per 700 cable pairs or fraction thereof	I		CLO	PE1B7	592.00													
	Physical Collocation - Co-Carrier Cross Connects/Direct Connect - Fiber Cable Support Structure, per linear ft.			CLO	PE1ES	0.001													
	Physical Collocation - Co-Carrier Cross Connect/Direct Connect - Copper/Coax Cable Support Structure, per lin. ft.			CLO	PE1DS	0.0014													
	Physical Collocation - Co-Carrier Cross Connects/Direct Connect, Application Fee, per application			CLO	PE1DT	584.11													
	Physical Collocation - Copper Entrance Cable per Cable (CO manhole to vault splice)			CLO	PE1EA	1,169.133	42.712												
	Physical Collocation - Copper Entrance Cable installation, per 100 Pairs			CLO	PE1EB	18.009													
	Physical Collocation - Fiber Entrance Cable per Cable (CO manhole to vault splice)			CLO	PE1EC	973.661	42.712												
	Physical Collocation - Fiber Entrance Cable Installation, per Fiber			CLO	PE1ED	7.24													
	Physical Collocation - Co-Carrier Cross Connect/Direct Connect - Fiber Cable Support Structure, per cable	I		CLO	PE1DU	535.54													
	Physical Collocation - Co-Carrier Cross Connect/Direct Connect - Copper/Coax Cable Support Structure, per cable	I		CLO	PE1DV	535.54													
<b>ADJACENT COLLOCATION</b>																			
	Adjacent Collocation - Space Charge per Sq. Ft.			CLOAC	PE1JA	0.1635													
	Adjacent Collocation - Electrical Facility Charge per Linear Ft.			CLOAC	PE1JC	5.11													
	Adjacent Collocation - 2-Wire Cross-Connects			UEA,UHL,U DL,UCL	PE1P2	0.0213	24.69	23.69	11.77	10.62									
	Adjacent Collocation - 4-Wire Cross-Connects			UEA,UHL,U DL,UCL	PE1P4	0.0426	24.88	23.83	12.04	10.80									
	Adjacent Collocation - DS1 Cross-Connects			UEA,UHL,U DL,UCL	PE1P1	1.22	44.24	31.98	12.07	10.91									
	Adjacent Collocation - DS3 Cross-Connects			UEA,UHL,U DL,UCL	PE1P3	16.56	41.94	30.52	13.91	11.15									
	Adjacent Collocation - 2-Fiber Cross-Connect			CLOAC	PE1F2	2.81	41.94	30.52	13.91	11.16									
	Adjacent Collocation - 4-Fiber Cross-Connect			CLOAC	PE1F4	5.36	51.30	39.87	18.29	15.54									
	Adjacent Collocation - Application Fee			CLOAC	PE1JB		2,785.00												
	Adjacent Collocation - 120V, Single Phase Standby Power Rate per AC Breaker Amp			CLOAC	PE1FB	5.38													
	Adjacent Collocation - 240V, Single Phase Standby Power Rate per AC Breaker Amp			CLOAC	PE1FD	10.77													
	Adjacent Collocation - 120V, Three Phase Standby Power Rate per AC Breaker Amp			CLOAC	PE1FE	16.15													
	Adjacent Collocation - 277V, Three Phase Standby Power Rate per AC Breaker Amp			CLOAC	PE1FG	37.30													
	Adjacent Collocation - Cable Support Structure per Entrance Cable	I		CLOAC	PE1PM	18.96													
<b>PHYSICAL COLLOCATION IN THE REMOTE SITE</b>																			
	Physical Collocation in the Remote Site - Application Fee			CLORS	PE1RA	617.91			328.81										
	Cabinet Space in the Remote Site per Bay/ Rack			CLORS	PE1RB	219.49													
	Physical Collocation in the Remote Site - Security Access - Key			CLORS	PE1RD	26.30													
	Physical Collocation in the Remote Site - Space Availability Report per Premises Requested			CLORS	PE1SR	232.69													

COLLOCATION - Florida						Attachment: 4		Exhibit: B					
CATEGORY	RATE ELEMENTS	Interim	Zone	BCS	USOC	RATES (\$)		Svc Order Submitted Elec per LSR	Svc Order Submitted Manually per LSR	Incremental Charge - Manual Svc Order vs. Electronic-1st	Incremental Charge - Manual Svc Order vs. Electronic-Add'l	Incremental Charge - Manual Svc Order vs. Electronic-Disc 1st	Incremental Charge - Manual Svc Order vs. Electronic-Disc Add'l
						Rec	Nonrecurring First						
						SOMEc	SOMAN	SOMAN	SOMAN	SOMAN	SOMAN		
	Physical Collocation in the Remote Site - Remote Site CLI Code Request, per CLI Code Requested			CLORS	PE1RE		75.41						
	Remote Site DLEC Data (BRSD), per Compact Disk, per CO			CLORS	PE1RR		233.51						
	Physical Collocation - Security Escort for Basic Time - normally scheduled work, per half hour			CLORS	PE1BT		16.52	10.83					
	Physical Collocation - Security Escort for Overtime - outside of normally scheduled working hours on a scheduled work day, per half hour			CLORS	PE1OT		21.92	14.19					
	Physical Collocation - Security Escort for Premium Time - outside of scheduled work day, per half hour			CLORS	PE1PT		27.31	17.55					
PHYSICAL COLLOCATION IN THE REMOTE SITE - ADJACENT													
	Remote Site-Adjacent Collocation - AC Power, per breaker amp			CLORS	PE1RS		6.27						
	Remote Site-Adjacent Collocation - Real Estate, per square foot			CLORS	PE1RT		0.134						
	Remote Site-Adjacent Collocation-Application Fee			CLORS	PE1RU		755.62	755.62					
NOTE: If Security Escort and/or Add'l Engineering Fees become necessary for remote site collocation, the Parties will negotiate appropriate rates.													
VIRTUAL COLLOCATION													
	Virtual Collocation - Application Fee			AMTFS	BAF		4,122.00	1,249.00					
	Virtual Collocation Administrative Only - Application Fee			AMTFS	VE1AF			742.00					
	Virtual Collocation - Cable Installation Cost, per cable			AMTFS	EGPCX		12.45	965.00					
	Virtual Collocation - Floor Space, per sq. ft.			AMTFS	ESPVX		4.25						
	Virtual Collocation - Power, per fused amp			AMTFS	ESPAX		6.95						
	Virtual Collocation - Cable Support Structure, per entrance cable			AMTFS	ESPSX		13.35						
	Virtual Collocation - 2-wire Cross Connects (loop)			UEANL,UEA,UDN,U DC,UAL,UHL,UCL,U EQ,UNCVX, UNCDX,UNCNX	UEAC2		0.0502	11.57					
	Virtual Collocation - 4-wire Cross Connects (loop)			UEA,UHL,UCL,UDL, UAL,UDN,UNCVX, UNCDX	UEAC4		0.0502	11.57					
	Virtual Collocation - 2-Fiber Cross Connects			UDL12,UDL03,U1T48,U1T12,U1T03,ULD03,ULD12,ULD48,UDF	CNC2F		6.71	2,431.00					
	Virtual Collocation - 4-Fiber Cross Connects			UDL12,UDL03,U1T48,U1T12,U1T03,ULD03,ULD12,ULD48,UDF	CNC4F		6.71	2,431.00					
	Virtual collocation - Special Access & UNE, cross-connect per DS1			USL,UCL,ULR,UXTD1,UNC1X,ULDD1,U1TD1,USLEL,UNLD1,UEPEX,UEPDX	CNC1X		7.50	155.00	14.00				
	Virtual collocation - Special Access & UNE, cross-connect per DS3			USL,UE3,U1TD3,UXTS1,UXTD3,UNC3X,UNC3X,ULDD3,U1TS1,ULDS1,UDLSX,UNLD3	CND3X		56.25	151.00	11.83				
	Virtual Collocation - Co-Carrier Cross Connects - Fiber Cable Support Structure, per linear foot			AMTFS	VE1CB		0.0028						
	Virtual Collocation - Co-Carrier Cross Connects - Copper/Coax Cable Support Structure, per linear ft			AMTFS	VE1CD		0.0041						
	Virtual Collocation - Co-Carrier Cross Connects - Fiber Cable Support Structure, per cable			AMTFS	VE1CC		535.54						

COLLOCATION - Florida						Svc Order Submitted Elec per LSR	Svc Order Submitted Manually per LSR	Attachment: 4		Exhibit: B			
CATEGORY	RATE ELEMENTS	Interim	Zone	BCS	USOC	RATES (\$)				Incremental Charge - Manual Svc Order vs. Electronic-1st	Incremental Charge - Manual Svc Order vs. Electronic-Add'l	Incremental Charge - Manual Svc Order vs. Electronic-Disc 1st	Incremental Charge - Manual Svc Order vs. Electronic-Disc Add'l
						Rec	Nonrecurring First	Nonrecurring Add'l	Nonrecurring Disconnect First	Nonrecurring Disconnect Add'l	SOME C	SOMAN	SOMAN
	Virtual Collocation - Co-Carrier Cross Connects - Copper/Coax Cable Support Structure, per cable			AMTFS	VE1CE		535.54						
	Virtual Collocation Cable Records - per request			AMTFS	VE1BA		1,525.00		267.08				
	Virtual Collocation Cable Records - VG/DS0 Cable, per cable record			AMTFS	VE1BB		656.50		379.78				
	Virtual Collocation Cable Records - VG/DS0 Cable, per each 100 pair			AMTFS	VE1BC		9.66		11.84				
	Virtual Collocation Cable Records - DS1, per T1TIE			AMTFS	VE1BD		4.52		5.54				
	Virtual Collocation Cable Records - DS3, per T3TIE			AMTFS	VE1BE		15.82		19.40				
	Virtual Collocation Cable Records - Fiber Cable, per 99 fiber records			AMTFS	VE1BF		169.67		154.89				
	Virtual collocation - Security Escort - Basic, per quarter hour			AMTFS	SPTBQ		10.89						
	Virtual collocation - Security Escort - Overtime, per quarter hour			AMTFS	SPTOQ		13.54						
	Virtual collocation - Security Escort - Premium, per quarter hour			AMTFS	SPTPQ		16.40						
	Virtual Collocation - 2-wire Cross Connects (loop), per ckts			AMTFS	VE1R2	0.05	11.57						
	Virtual Collocation - 4-wire Cross Connects (loop), per ckts			AMTFS	VE1R4	0.05	11.57						
	Virtual Collocation - DS-1/DCS Cross Connects, PER CKTS			AMTFS	VE11S	8.09	69.64						
	Virtual Collocation - DS-1/DSX Cross Connects, PER CKTS			AMTFS	VE11X	0.41	69.64						
	Virtual Collocation - DS-3/DCS Cross Connects, PER CKT			AMTFS	VE13S	59.67	528.00						
	Virtual Collocation - DS-3/DSC Cross Connects, PER CKT			AMTFS	VE13X	10.06	528.00						
	Virtual collocation - Maintenance in CO - Basic, per quarter hour			AMTFS	SPTRE		10.89						
	Virtual collocation - Maintenance in CO - Overtime, per quarter hour			AMTFS	SPTOE		13.64						
	Virtual collocation - Maintenance in CO - Premium per quarter hour			AMTFS	SPTPE		16.40						
	Virtual Collocation - Request Resend of CFA Information, per CLLI			AMTFS	VE1QR		77.54						
<b>VIRTUAL COLLOCATION</b>													
	Virtual Collocation - 2-wire Cross Connect, Exchange Port 2-Wire Analog - Res			UEPSR	VE1R2	0.0502	11.57	11.57					
	Virtual Collocation 2-Wire Cross Connect, Exchange Port 2-Wire Line Side PBX Trunk - Bus			UEPSP	VE1R2	0.0502	11.57	11.57					
	Virtual Collocation 2-Wire Cross Connect, Exchange Port 2-Wire Voice Grade PBX Trunk - Res			UEPSE	VE1R2	0.0502	11.57	11.57					
	Virtual Collocation 2-Wire Cross Connect, Exchange Port 2-Wire Analog Bus			UEPSB	VE1R2	0.0502	11.57	11.57					
	Virtual Collocation 2-Wire Cross Connect, Exchange Port 2-Wire ISDN			UEPSX	VE1R2	0.0502	11.57	11.57					
	Virtual Collocation 2-Wire Cross Connect, Exchange Port 2-Wire ISDN			UEPTX	VE1R2	0.0502	11.57	11.57					
	Virtual Collocation 4-Wire Cross Connect, Exchange Port 4-Wire ISDN DS1			UEPEX	VE1R4	0.0502	11.57	11.57					

Note: Rates displaying an "R" in Interim column are interim and subject to rate true-up as set forth in General Terms and Conditions.

**Attachment 5**  
**Access to Numbers and Number Portability**



**TABLE OF CONTENTS**

**1. NON-DISCRIMINATORY ACCESS TO TELEPHONE NUMBERS ..... 3**

**2. LOCAL SERVICE PROVIDER NUMBER PORTABILITY - PERMANENT SOLUTION (LNP)..... 3**

**3. OPERATIONAL SUPPORT SYSTEM (OSS) RATES ..... 4**

## **ACCESS TO NUMBERS AND NUMBER PORTABILITY**

### **1. NON-DISCRIMINATORY ACCESS TO TELEPHONE NUMBERS**

- 1.1 During the term of this Agreement, where Local Line is utilizing its own switch, Local Line shall contact the North American Numbering Plan Administrator, NeuStar, for the assignment of numbering resources. In order to be assigned a Central Office Code, Local Line will be required to complete the Central Office Code (NXX) Assignment Request and Confirmation Form (Code Request Form) in accordance with Industry Numbering Committee's Central Office Code (NXX) Assignment Guidelines (INC 95-0407-008).
- 1.2 Where BellSouth provides local switching or resold services to Local Line, BellSouth will provide Local Line with on-line access to intermediate telephone numbers as defined by applicable FCC rules and regulations on a first come first served basis. Local Line acknowledges that such access to numbers shall be in accordance with the appropriate FCC rules and regulations. Local Line acknowledges that there may be instances where there is a shortage of telephone numbers in a particular rate center; and in such instances, BellSouth may request that Local Line return unused intermediate numbers to BellSouth. Local Line shall return unused intermediate numbers to BellSouth upon BellSouth's request. BellSouth shall make all such requests on a nondiscriminatory basis.
- 1.3 BellSouth will allow Local Line to designate up to 100 intermediate telephone numbers per rate center for Local Line's sole use. Assignment, reservation and use of telephone numbers shall be governed by applicable FCC rules and regulations. Local Line acknowledges that there may be instances where there is a shortage of telephone numbers in a particular rate center and BellSouth has the right to limit access to blocks of intermediate telephone numbers. These instances include: 1) where jeopardy status has been declared by the North American Numbering Plan (NANP) for a particular Numbering Plan Area (NPA); or 2) where a rate center has less than six months supply of numbering resources.

### **2. LOCAL SERVICE PROVIDER NUMBER PORTABILITY - PERMANENT SOLUTION (LNP)**

- 2.1 The Parties will offer Number Portability in accordance with rules, regulations and guidelines adopted by the Commission, the FCC and industry fora.
- 2.2 End User Line Charge. Where Local Line subscribes to BellSouth's local switching, BellSouth shall bill and Local Line shall pay the end user line charge associated with implementing LNP as set forth in BellSouth's FCC Tariff No. 1.

This charge is not subject to the resale discount set forth in Attachment 1 of this Agreement.

- 2.3 To limit service outage, BellSouth and Local Line will adhere to the process flows and cutover guidelines for porting numbers as outlined in the LNP Reference Guide, as amended from time to time. The LNP Reference Guide, incorporated herein by reference, is accessible via the Internet at the following site: <http://www.interconnection.bellsouth.com>. All intervals referenced in the LNP Reference Guide shall apply to both BellSouth and Local Line.
- 2.4 The Parties will set Location Routing Number (LRN) unconditional or 10-digit triggers where applicable. Where triggers are set, the porting Party will remove the ported number at the same time the trigger is removed.
- 2.5 A trigger order is a service order issued in advance of the porting of a number. A trigger order 1) initiates call queries to the AIN SS7 network in advance of the number being ported; and 2) provides for the new service provider to be in control of when a number ports.
- 2.6 Where triggers are not set, the Parties shall coordinate the porting of the number between service providers so as to minimize service interruptions to the End User.
- 2.7 BellSouth and Local Line will work cooperatively to implement changes to LNP process flows ordered by the FCC or as recommended by standard industry forums addressing LNP.

### **3. OPERATIONAL SUPPORT SYSTEM (OSS) RATES**

- 3.1 The terms, conditions and rates for OSS are as set forth in Attachment 2.

**Attachment 6**

**Pre-Ordering, Ordering, Provisioning,  
Maintenance and Repair**

**TABLE OF CONTENTS**

1. **QUALITY OF PRE-ORDERING, ORDERING, PROVISIONING, MAINTENANCE AND REPAIR ...3**

2. **ACCESS TO OPERATIONS SUPPORT SYSTEMS .....3**

3. **MISCELLANEOUS .....5**

## **PRE-ORDERING, ORDERING, PROVISIONING, MAINTENANCE AND REPAIR**

- 1. QUALITY OF PRE-ORDERING, ORDERING, PROVISIONING, MAINTENANCE AND REPAIR**
  - 1.1 BellSouth shall provide to Local Line nondiscriminatory access to its Operations Support Systems (OSS) and the necessary information contained therein in order that Local Line can perform the functions of pre-ordering, ordering, provisioning, maintenance and repair, and billing.. BellSouth shall provide Local Line with all relevant documentation (manuals, user guides, specifications, etc.) regarding business rules and other formatting information as well as practices and procedures necessary to ensure requests are efficiently processed. All documentation will be readily accessible at BellSouth's interconnection website and are incorporated herein by reference. BellSouth shall ensure that its OSS are designed to accommodate access requests for both current and projected demand of Local Line and other CLECs in the aggregate.
  - 1.2 BellSouth shall provision services during its regular working hours. To the extent Local Line requests provisioning of service to be performed outside BellSouth's regular working hours, or the work so requested requires BellSouth's technicians or project manager to work outside of regular working hours, overtime charges shall apply. Notwithstanding the foregoing, if such work is performed outside of regular working hours by a BellSouth technician or project manager during his or her scheduled shift and BellSouth does not incur any overtime charges in performing the work on behalf of Local Line, BellSouth will not assess Local Line additional charges beyond the rates and charges specified in this Agreement.
- 2. ACCESS TO OPERATIONS SUPPORT SYSTEMS**
  - 2.1 BellSouth shall provide Local Line nondiscriminatory access to its OSS and the necessary information contained therein in order that Local Line can perform the functions of pre-ordering, ordering, provisioning, maintenance and repair, and billing. BellSouth shall provide nondiscriminatory access to the OSS through manual and/or electronic interfaces as described in this Attachment. It is the sole responsibility of Local Line to obtain the technical capability to access and utilize BellSouth's OSS interfaces. Specifications for Local Line's access and use of BellSouth's electronic interfaces are set forth at BellSouth's interconnection website and are incorporated herein by reference.
    - 2.1.1 Pre-Ordering. BellSouth will provide electronic access to its OSS and the information contained therein in order that Local Line can perform the following pre-ordering functions: service address validation, telephone number selection, service and feature availability, due date information, customer record information and loop makeup information. Mechanized access is provided by electronic

interfaces whose specifications for access and use are set forth at BellSouth's interconnection website and are incorporated herein by reference. The process by which BellSouth and Local Line will manage these electronic interfaces to include the development and introduction of new interfaces will be governed by the change management process as described below. Local Line shall provide to BellSouth access to customer record information, including circuit numbers associated with each telephone number where applicable. Local Line shall provide such information within four (4) hours after request via electronic access where available. If electronic access is not available, Local Line shall provide to BellSouth paper copies of customer record information, including circuit numbers associated with each telephone number where applicable. If BellSouth requests the information before noon, the customer record information shall be provided the same day. If BellSouth requests the information after noon, the customer record information shall be provided by noon the following day.

2.1.2 The Parties agree not to view, copy, or otherwise obtain access to the customer record information of any customer without that customer's permission. Local Line will obtain access to customer record information only in strict compliance with applicable laws, rules, or regulations of the state in which the service is provided. BellSouth reserves the right to audit Local Line's access to customer record information. If a BellSouth audit of Local Line's access to customer record information reveals that Local Line is accessing customer record information without having obtained the proper End User authorization, BellSouth upon reasonable notice to Local Line may take corrective action, including but not limited to suspending or terminating Local Line's electronic access to BellSouth's OSS functionality. All such information obtained through an audit shall be deemed Information covered by the Proprietary and Confidential Information section in the General Terms and Conditions of this Agreement.

2.1.3 Ordering. BellSouth will make available to Local Line electronic interfaces for the purpose of exchanging order information, including order status and completion notification, for non-complex and certain complex resale requests and certain network elements. Specifications for access and use of BellSouth's electronic interfaces are set forth at BellSouth's interconnection website and are incorporated herein by reference. The process by which BellSouth and Local Line will manage these electronic interfaces to include the development and introduction of new interfaces will be governed by the change management process as described below.

2.1.4 Maintenance and Repair. BellSouth will make available to Local Line electronic interfaces for the purpose of reporting and monitoring service troubles. Specifications for access and use of BellSouth's maintenance and repair electronic interfaces are set forth at BellSouth's interconnection website and are incorporated herein by reference. The process by which BellSouth and Local Line will manage these electronic interfaces to include the development and introduction of new interfaces will be governed by the change management process as described below. Requests for trouble repair are billed in accordance with the provisions of this Agreement. BellSouth and Local Line agree to adhere to BellSouth's Operational

Understanding, as amended from time to time during this Agreement and as incorporated herein by reference. The Operational Understanding may be accessed via BellSouth's interconnection website.

- 2.1.5 Billing. BellSouth will provide Local Line nondiscriminatory access to billing information as specified in Attachment 7 to this Agreement.
- 2.2 Change Management. BellSouth and Local Line agree that the collaborative change management process known as the Change Control Process (CCP) will be used to manage changes to existing interfaces, introduction of new interfaces and retirement of interfaces. BellSouth and Local Line agree to comply with the provisions of the documented Change Control Process as may be amended from time to time and incorporated herein by reference. The change management process will cover changes to BellSouth's electronic interfaces, BellSouth's testing environment, associated manual process improvements, and relevant documentation. The process will define a procedure for resolution of change management disputes. Documentation of the CCP as well as related information and processes will be clearly organized and readily accessible to Local Line at BellSouth's interconnection website.
- 2.3 Rates. Charges for use of OSS shall be as set forth in this Agreement.

### 3. MISCELLANEOUS

- 3.1 Pending Orders. Orders placed in the hold or pending status by Local Line will be held for a maximum of thirty (30) calendar days from the date the order is placed on hold. After such time, Local Line shall be required to submit a new service request. Incorrect or invalid requests returned to Local Line for correction or clarification will be held for thirty (30) calendar days. If Local Line does not return a corrected request within thirty (30) calendar days, BellSouth will cancel the request.
- 3.2 Single Point of Contact. Local Line will be the single point of contact with BellSouth for ordering activity for network elements and other services used by Local Line to provide services to its End Users, except that BellSouth may accept a request directly from another CLEC, or BellSouth, acting with authorization of the affected End User. Local Line and BellSouth shall each execute a blanket letter of authorization with respect to customer requests so that prior proof of End User authorization will not be necessary with every request (except in the case of a local service freeze). The Parties shall each be entitled to adopt their own internal processes for verification of customer authorization for requests, provided, however, that such processes shall comply with applicable state and federal law and industry and regulatory guidelines. Pursuant to a request from another carrier, BellSouth may disconnect any network element being used by Local Line to provide service to that End User and may reuse such network elements or facilities to enable such other carrier to provide service to the End User. BellSouth will



notify Local Line that such a request has been processed but will not be required to notify Local Line in advance of such processing.

- 3.2.1 Neither BellSouth nor Local Line shall prevent or delay an End User from migrating to another carrier because of unpaid bills, denied service, or contract terms.
- 3.2.2 BellSouth shall return a Firm Order Confirmation (FOC) and Local Service Request (LSR) rejection/clarification within the intervals in accordance with the Service Quality Measurement (SQM) set forth in Attachment 9 of this Agreement.
- 3.2.3 Local Line shall return a FOC to BellSouth within thirty-six (36) hours after Local Line's receipt from BellSouth of a valid LSR.
- 3.2.4 Local Line shall provide a Reject Response to BellSouth within twenty-four (24) hours after BellSouth's submission of an LSR which is incomplete or incorrectly formatted.
- 3.3 Use of Facilities. When a customer of Local Line elects to discontinue service and to transfer service to another local exchange carrier, including BellSouth, BellSouth shall have the right to reuse the facilities provided to Local Line by BellSouth. In addition, where BellSouth provides local switching, BellSouth may disconnect and reuse facilities when the facility is in a denied state and BellSouth has received a request to establish new service or transfer of service from a customer or a customer's CLEC at the same address served by the denied facility. BellSouth will notify Local Line that such a request has been processed after the disconnect order has been completed.
- 3.4 Contact Numbers. The Parties agree to provide one another with toll-free nationwide (50 states) contact numbers for the purpose of ordering, provisioning and maintenance of services.
- 3.5 Subscription Functions. In cases where BellSouth performs subscription functions for an interexchange carrier (IXC) (i.e. PIC and LPIC changes via Customer Account Record Exchange (CARE)), BellSouth will in all possible instances provide the affected IXCs with the Operating Company Number (OCN) of the local provider for the purpose of obtaining End User billing account and other End User information required under subscription requirements.
- 3.5.1 When Local Line's End User, served by resale or loop and port combinations, changes its PIC or LPIC, and per BellSouth's FCC or state tariff the interexchange carrier elects to charge the End User the PIC or LPIC change charge, BellSouth will bill the PIC or LPIC change charge to Local Line, which has the billing relationship with that End User, and Local Line may pass such charge to the End User.

- 3.6 Cancellation Charges. If Local Line cancels a request for network elements or resold services, any costs incurred by BellSouth in conjunction with the provisioning of that request will be recovered in accordance with BellSouth's Private Line Tariff or BellSouth's FCC No. 1 Tariff, Section 5.4, as applicable. Notwithstanding the foregoing, if Local Line places an LSR based upon BellSouth's loop makeup information, and such information is inaccurate resulting in the inability of BellSouth to provision the network elements requested and another spare compatible facility cannot be found with the transmission characteristics of the network elements originally requested, cancellation charges described in this Section shall not apply. Where Local Line places a single LSR for multiple network elements or services based upon loop makeup information, and information as to some, but not all, of the network elements or services is inaccurate, if BellSouth cannot provision the network elements or services that were the subject of the inaccurate loop makeup information, Local Line may cancel its request for those network elements or services without incurring cancellation charges as described in this Section. In such instance, should Local Line elect to cancel the entire LSR, cancellation charges as described in this Section shall apply to those elements and services that were not the subject of inaccurate loop makeup.
- 3.7 Service Date Advancement Charges (a.k.a. Expedites). For Service Date Advancement requests by Local Line, Service Date Advancement charges will apply for intervals less than the standard interval as outlined in the BellSouth Product and Services Interval Guide. The charges as outlined in BellSouth's FCC No. 1 Tariff, Section 5, will apply as applicable.

**Attachment 7**

**Billing**

**TABLE OF CONTENTS**

**1. PAYMENT AND BILLING ARRANGEMENTS..... 3**

**2. BILLING DISPUTES..... 6**

**3. RAO HOSTING..... 7**

**4. OPTIONAL DAILY USAGE FILE ..... 11**

**5. ACCESS DAILY USAGE FILE ..... 13**

**6. ENHANCED OPTIONAL DAILY USAGE FILE (EODUF) ..... 15**

**Rates.....Exhibit A**

## BILLING

### 1. PAYMENT AND BILLING ARRANGEMENTS

The terms and conditions set forth in this Attachment shall apply to all services ordered and provisioned pursuant to this Agreement.

- 1.1 Billing. BellSouth will bill through the Carrier Access Billing System (CABS), Integrated Billing System (IBS) and/or the Customer Records Information System (CRIS) depending on the particular service(s) provided to Local Line under this Agreement. BellSouth will format all bills in Carrier Billing Output Specification (CBOS) Standard or CLUB/EDI format, depending on the type of service provided. For those services where standards have not yet been developed, BellSouth's billing format will change as necessary when standards are finalized by the applicable industry forum.
  - 1.1.1 For any service(s) BellSouth receives from Local Line, Local Line shall bill BellSouth in CBOS format.
  - 1.1.2 Any switched access charges associated with interexchange carrier access to the resold local exchange lines will be billed by, and due to BellSouth.
  - 1.1.3 BellSouth will render bills each month on established bill days for each of Local Line's accounts. If either Party requests multiple billing media or additional copies of the bills, the billing Party will provide these at a reasonable cost.
  - 1.1.4 BellSouth will bill Local Line in advance for all services to be provided during the ensuing billing period except charges associated with service usage and nonrecurring charges, which will be billed in arrears.
    - 1.1.4.1 Charges for services will be calculated on an individual End User account level, including, if applicable, any charge for usage or usage allowances. BellSouth will also bill Local Line, and Local Line will be responsible for and remit to BellSouth, all charges applicable to said services including but not limited to 911 and E911 charges, End Users common line charges, federal subscriber line charges, telecommunications relay charges (TRS), and franchise fees, unless otherwise ordered by a Commission.
  - 1.1.5 BellSouth will not perform billing and collection services for Local Line as a result of the execution of this Agreement.
  - 1.1.6 In the event that this Agreement or an amendment to this Agreement effects a rate change to recurring rate elements that are billed in advance, BellSouth will make an adjustment to such recurring rates billed in advance at the previously effective rate. The adjustment shall reflect billing at the new rates from the Effective Date of the Agreement or amendment.

- 1.2 Establishing Accounts. After submitting a credit profile and deposit, if required, and after receiving certification as a local exchange carrier from the appropriate regulatory agency, Local Line will provide the appropriate BellSouth advisory team/local contract manager the necessary documentation to enable BellSouth to establish accounts for Local Interconnection, Network Elements and Other Services, Collocation and/or resold services. Such documentation shall include the Application for Master Account, if applicable, proof of authority to provide telecommunications services, the appropriate Operating Company Numbers (OCN) for each state as assigned by the National Exchange Carriers Association (NECA), Carrier Identification Code (CIC), Access Customer Name and Abbreviation (ACNA), Blanket Letter of Authorization (LOA), Misdirected Number form, and a tax exemption certificate, if applicable. Notwithstanding anything to the contrary in this Agreement, Local Line may not order services under a new account established in accordance with this Section 1.2 until 30 days after all information specified in this Section 1.2 is received from Local Line.
- 1.2.1 OCN. If Local Line needs to change its OCN(s) under which it operates when Local Line has already been conducting business utilizing those OCN(s), Local Line shall bear all costs incurred by BellSouth to convert Local Line to the new OCN(s). OCN conversion charges include all time required to make system updates to all of Local Line's End User customer records and will be handled by the BFR/NBR process.
- 1.2.2 Payment Responsibility. Payment of all charges will be the responsibility of Local Line. Local Line shall make payment to BellSouth for all services billed. Payments made by Local Line to BellSouth as payment on account will be credited to Local Line's accounts receivable master account. BellSouth will not become involved in billing disputes that may arise between Local Line and Local Line's customer.
- 1.3 Payment Due. Payment for services provided is due on or before the next bill date in immediately available funds. Payment is considered to have been made when received by BellSouth.
- 1.4 Due Dates. If the payment due date falls on a Sunday or on a holiday that is observed on a Monday, the payment due date shall be the first non-holiday day following such Sunday or holiday. If the payment due date falls on a Saturday or on a holiday which is observed on Tuesday, Wednesday, Thursday, or Friday, the payment due date shall be the last non-holiday day preceding such Saturday or holiday. If payment is not received by the payment due date, a late payment charge, as set forth in Section 1.6, below, shall apply.
- 1.5 Tax Exemption. Upon BellSouth's receipt of tax exemption certificate, the total amount billed to Local Line will not include those taxes or fees from which Local Line is exempt. Local Line will be solely responsible for the computation, tracking, reporting and payment of all taxes and like fees associated with the services provided to the End User of Local Line.

- 1.6 Late Payment. If any portion of the payment is not received by BellSouth on or before the payment due date as set forth preceding, or if any portion of the payment is received by BellSouth in funds that are not immediately available to BellSouth, then a late payment charge shall be due to BellSouth. The late payment charge shall be the portion of the payment not received by the payment due date multiplied by a late factor and will be applied on a per bill basis. The late factor shall be as set forth in Section A2 of the General Subscriber Services Tariff, Section B2 of the Private Line Service Tariff or Section E2 of the Intrastate Access Tariff, as appropriate. In addition to any applicable late payment charges, Local Line may be charged a fee for all returned checks as set forth in Section A2 of the General Subscriber Services Tariff or pursuant to the applicable state law.
- 1.7 Discontinuing Service to Local Line. The procedures for discontinuing service to Local Line are as follows:
- 1.7.1 BellSouth reserves the right to suspend or terminate service in the event of prohibited, unlawful or improper use of BellSouth facilities or service, abuse of BellSouth facilities, or any other violation or noncompliance by Local Line of the rules and regulations of BellSouth's tariffs.
- 1.7.2 BellSouth reserves the right to suspend or terminate service for nonpayment. If payment of amounts not subject to a billing dispute, as described in Section 2, is not received by the bill date in the month after the original bill date, BellSouth will provide written notice to Local Line that additional applications for service may be refused, that any pending orders for service may not be completed, and/or that access to ordering systems may be suspended if payment of such amounts, and all other amounts not in dispute that become past due before refusal, incompleteness or suspension, is not received by the fifteenth day following the date of the notice. In addition, BellSouth may, at the same time, provide written notice to the person designated by Local Line to receive notices of noncompliance that BellSouth may discontinue the provision of existing services to Local Line if payment of such amounts, and all other amounts not in dispute that become past due before discontinuance, is not received by the thirtieth day following the date of the initial notice.
- 1.7.3 In the case of discontinuance of services, all billed charges, as well as applicable termination charges, shall become due.
- 1.7.4 Discontinuance of service on Local Line's account will effect a discontinuance of service to Local Line's End Users. BellSouth will reestablish service for Local Line upon payment of all past due charges and the appropriate connection fee subject to BellSouth's normal application procedures. Local Line is solely responsible for notifying the End User of the discontinuance of the service. If within fifteen (15) days after Local Line's service has been discontinued and no arrangements to reestablish service have been made consistent with this subsection, Local Line's service will be disconnected.

- 1.8 Deposit Policy. Local Line shall complete the BellSouth Credit Profile and provide information to BellSouth regarding credit worthiness. Based on the results of the credit analysis, BellSouth reserves the right to secure the account with a suitable form of security deposit. Such security deposit shall take the form of cash, an Irrevocable Letter of Credit (BellSouth form), Surety Bond (BellSouth form) or, in BellSouth's sole discretion, some other form of security proposed by Local Line. Any such security deposit shall in no way release Local Line from its obligation to make complete and timely payments of its bill. Local Line shall pay any applicable deposits prior to the inauguration of service. If, in the sole opinion of BellSouth, circumstances so warrant and/or gross monthly billing has increased beyond the level initially used to determine the level of security deposit, BellSouth reserves the right to request additional security and/or file a Uniform Commercial Code (UCC-1) security interest in Local Line's "accounts receivables and proceeds." Interest on a security deposit, if provided in cash, shall accrue and be paid in accordance with the terms in the appropriate BellSouth tariff. Security deposits collected under this Section shall not exceed two months' estimated billing. In the event Local Line fails to remit to BellSouth any deposit requested pursuant to this Section, service to Local Line may be terminated in accordance with the terms of Section 1.7 of this Attachment, and any security deposits will be applied to Local Line's account(s). In the event Local Line defaults on its account, service to Local Line will be terminated in accordance with the terms of Section 1.7 above, and any security deposits will be applied to Local Line's account.
- 1.9 Notices. Notwithstanding anything to the contrary in this Agreement, all bills and notices regarding billing matters, including notices relating to security deposits, disconnection of services for nonpayment of charges, and rejection of additional orders from Local Line, shall be forwarded to the individual and/or address provided by Local Line in establishment of its billing account(s) with BellSouth, or to the individual and/or address subsequently provided by Local Line as the contact for billing information. All monthly bills and notices described in this Section shall be forwarded to the same individual and/or address; provided, however, upon written request from Local Line to BellSouth's billing organization, the notice of discontinuance of services purchased by Local Line under this Agreement provided for in Section 1.7.2 of this Attachment shall be sent via certified mail to the individual(s) listed in the Notices provision of the General Terms and Conditions of this Agreement.
- 1.10 Rates. Rates for Optional Daily Usage File (ODUF), Access Daily Usage File (ADUF), Enhanced Optional Daily Usage File (EODUF) and Centralized Message Distribution Service (CMDS) are set out in Exhibit A to this Attachment. If no rate is identified in this Attachment, the rate for the specific service or function will be as set forth in the applicable BellSouth tariff or as negotiated by the Parties upon request by either Party.

**2. BILLING DISPUTES**



2.1 Each Party agrees to notify the other Party in writing upon the discovery of a billing dispute. Local Line shall report all billing disputes to BellSouth using the Billing Adjustment Request Form (RF 1461) provided by BellSouth. In the event of a billing dispute, the Parties will endeavor to resolve the dispute within sixty (60) calendar days of the notification date. If the Parties are unable within the 60 day period to reach resolution, then the aggrieved Party may pursue dispute resolution in accordance with the General Terms and Conditions of this Agreement.

2.2 For purposes of this Section 2, a billing dispute means a reported dispute of a specific amount of money actually billed by either Party. The dispute must be clearly explained by the disputing Party and supported by written documentation, which clearly shows the basis for disputing charges. A billing dispute will not include the refusal to pay all or part of a bill or bills when no written documentation is provided to support the dispute, nor shall a billing dispute include the refusal to pay other amounts owed by the billed Party until the dispute is resolved. Claims by the billed Party for damages of any kind will not be considered a billing dispute for purposes of this Section. If the billing dispute is resolved in favor of the billing Party, the disputing Party will make immediate payment of any of the disputed amount owed to the billing Party or the billing Party shall have the right to pursue normal treatment procedures. Any credits due to the disputing Party, pursuant to the billing dispute, will be applied to the disputing Party's account by the billing Party immediately upon resolution of the dispute.

If a Party disputes a charge and does not pay such charge by the payment due date, or if a payment or any portion of a payment is received by either Party after the payment due date, or if a payment or any portion of a payment is received in funds which are not immediately available to the other Party, then a late payment charge and interest, where applicable, shall be assessed. For bills rendered by either Party for payment, the late payment charge for both Parties shall be calculated based on the portion of the payment not received by the payment due date multiplied by the late factor as set forth in the following BellSouth tariffs: for services purchased from the General Subscribers Services Tariff for purposes of resale and for ports and non-designed loops, Section A2 of the General Subscriber Services Tariff; for services purchased from the Private Line Tariff for purposes of resale, Section B2 of the Private Line Service Tariff; and for designed network elements and other services and local interconnection charges, Section E2 of the Access Service Tariff. The Parties shall assess interest on previously assessed late payment charges only in a state where it has the authority pursuant to its tariffs.

### 3. **RAO HOSTING**

3.1 RAO Hosting, Calling Card and Third Number Settlement System (CATS) and Non-Intercompany Settlement System (NICS) services provided to Local Line by BellSouth will be in accordance with the methods and practices regularly applied

by BellSouth to its own operations during the term of this Agreement, including such revisions as may be made from time to time by BellSouth.

- 3.2 Local Line shall furnish all relevant information required by BellSouth for the provision of RAO Hosting, CATS and NICS.
- 3.3 Charges or credits, as applicable, will be applied by BellSouth to Local Line on a monthly basis in arrears. Amounts due (excluding adjustments) are payable within thirty (30) days of receipt of the billing statement.
- 3.4 Local Line must have its own unique hosted RAO code. Where BellSouth is the selected CMDS interfacing host, Local Line must request that BellSouth establish a unique hosted RAO code for Local Line. Such request shall be in writing to the BellSouth RAO Hosting coordinator and must be submitted at least eight (8) weeks prior to provision of services pursuant to this Section. Services shall commence on a date mutually agreed by the Parties.
- 3.5 BellSouth will receive messages from Local Line that are to be processed by BellSouth, another LEC in the BellSouth region or a LEC outside the BellSouth region. Local Line shall send all messages to BellSouth no later than sixty (60) days after the message date.
- 3.6 BellSouth will perform invoice sequence checking, standard EMI format editing, and balancing of message data with the EMI trailer record counts on all data received from Local Line.
- 3.7 All data received from Local Line that is to be processed or billed by another LEC within the BellSouth region will be distributed to that LEC in accordance with the Agreement(s) in effect between BellSouth and the involved LEC.
- 3.8 All data received from Local Line that is to be placed on the CMDS network for distribution outside the BellSouth region will be handled in accordance with the agreement(s) in effect between BellSouth and its connecting contractor.
- 3.9 BellSouth will receive messages from the CMDS network that are destined to be processed by Local Line and will forward them to Local Line on a daily basis for processing.
- 3.10 Transmission of message data between BellSouth and Local Line will be via CONNECT:Direct or Secure File Transfer Protocol (FTP).
- 3.10.1 Data circuits (private line or dial-up) will be required between BellSouth and Local Line for the purpose of data transmission when utilizing CONNECT:Direct. Where a dedicated line is required, Local Line will be responsible for ordering the circuit and coordinating the installation with BellSouth. Local Line is responsible for any charges associated with this line. Equipment required on the BellSouth end to attach the line to the mainframe computer and to transmit data will be

negotiated on an individual case basis. Where a dial-up facility is required, dial circuits will be installed in the BellSouth data center by BellSouth and the associated charges assessed to Local Line. Additionally, all message toll charges associated with the use of the dial circuit by Local Line will be the responsibility of Local Line. Associated equipment on the BellSouth end, including a modem, will be negotiated on an individual case basis between the Parties. All equipment, including modems and software, that is required on the Local Line end for the purpose of data transmission will be the responsibility of Local Line.

- 3.10.2 If Local Line utilizes Secure File Transfer Protocol for data file transmission, purchase of the Secure File Transfer Protocol software will be the responsibility of Local Line.
- 3.11 All messages and related data exchanged between BellSouth and Local Line will be formatted for EMI formatted records and packed between appropriate EMI header and trailer records in accordance with accepted industry standards.
- 3.12 Local Line will maintain recorded message detail necessary to recreate files provided to BellSouth for a period of three (3) calendar months beyond the related message dates.
- 3.13 Should it become necessary for Local Line to send data to BellSouth more than sixty (60) days past the message date(s), Local Line will notify BellSouth in advance of the transmission of the data. BellSouth will work with its connecting contractor and/or Local Line, where necessary, to notify all affected LECs.
- 3.14 In the event that data to be exchanged between the two Parties should become lost or destroyed, the Party responsible for creating the data will make every effort to restore and retransmit such data. If the data cannot be retrieved, the Party responsible for losing or destroying the data will be liable to the other Party for any resulting lost revenue. Lost revenue may be a combination of revenues that could not be billed to the End Users and associated access revenues. Both Parties will work together to estimate the revenue amount based upon historical data through a method mutually agreed upon. The resulting estimated revenue loss will be paid by the responsible Party to the other Party within three (3) calendar months of the resolution of the amount owed, or as mutually agreed upon by the Parties.
- 3.15 Should an error be detected by the EMI format edits performed by BellSouth on data received from Local Line, the entire pack containing the affected data will not be processed by BellSouth. BellSouth will notify Local Line of the error. Local Line will correct the error(s) and will resend the entire pack to BellSouth for processing. In the event that an out-of-sequence condition occurs on subsequent packs, Local Line will resend these packs to BellSouth after the pack containing the error has been successfully reprocessed by BellSouth.

- 3.16 In association with message distribution service, BellSouth will provide Local Line with associated intercompany settlements reports (CATS and NICS) as appropriate.
- 3.17 Notwithstanding anything in this Agreement to the contrary, in no case shall either Party be liable to the other for any direct or consequential damages incurred as a result of the obligations set out in this Section 3.
- 3.18 Intercompany Settlements Messages
- 3.18.1 Intercompany Settlements Messages facilitate the settlement of revenues associated with traffic originated from or billed by Local Line as a facilities based provider of local exchange telecommunications services outside the BellSouth region. Only traffic that originates in one Bell operating territory and bills in another Bell operating territory is included. Traffic that originates and bills within the same Bell operating territory will be settled on a local basis between Local Line and the involved company(ies), unless that company is participating in NICS.
- 3.18.2 Both traffic that originates outside the BellSouth region by Local Line and is billed within the BellSouth region, and traffic that originates within the BellSouth region and is billed outside the BellSouth region by Local Line, is covered by CATS. Also covered is traffic that either is originated by or billed by Local Line, involves a company other than Local Line, qualifies for inclusion in the CATS settlement, and is not originated or billed within the BellSouth region (NICS).
- 3.18.3 Once Local Line is operating within the BellSouth territory, revenues associated with calls originated and billed within the BellSouth region will be settled via NICS.
- 3.18.4 BellSouth will receive the monthly NICS reports from Telcordia on behalf of Local Line. BellSouth will distribute copies of these reports to Local Line on a monthly basis.
- 3.18.5 BellSouth will receive the monthly CATS reports from Telcordia on behalf of Local Line. BellSouth will distribute copies of these reports to Local Line on a monthly basis.
- 3.18.6 BellSouth will collect the revenue earned by Local Line from the Bell operating company in whose territory the messages are billed via CATS, less a per message billing and collection fee of five cents (\$0.05), on behalf of Local Line. BellSouth will remit the revenue billed by Local Line to the Bell operating company in whose territory the messages originated, less a per message billing and collection fee of five cents (\$0.05), on behalf on Local Line. These two amounts will be netted together by BellSouth and the resulting charge or credit issued to Local Line via a monthly Carrier Access Billing System (CABS) miscellaneous bill.

3.18.7 BellSouth will collect the revenue earned by Local Line within the BellSouth territory from another CLEC also within the BellSouth territory (NICS) where the messages are billed, less a per message billing and collection fee of five cents (\$0.05), on behalf of Local Line. BellSouth will remit the revenue billed by Local Line within the BellSouth region to the CLEC also within the BellSouth region, where the messages originated, less a per message billing and collection fee of five cents (\$0.05). These two amounts will be netted together by BellSouth and the resulting charge or credit issued to Local Line via a monthly CABS miscellaneous bill.

3.18.8 BellSouth and Local Line agree that monthly netted amounts of less than fifty dollars (\$50.00) will not be settled.

#### **4. OPTIONAL DAILY USAGE FILE**

4.1 Upon written request from Local Line, BellSouth will provide the Optional Daily Usage File (ODUF) service to Local Line pursuant to the terms and conditions set forth in this section.

4.2 Local Line shall furnish all relevant information required by BellSouth for the provision of the ODUF.

4.3 The ODUF feed will contain billable messages that were carried over the BellSouth Network and processed in the BellSouth Billing System, but billed to a Local Line customer.

4.4 Charges for the ODUF will appear on Local Lines' monthly bills for the previous month's usage. The charges are as set forth in Exhibit A to this Attachment. Local Line will be billed at the ODUF rates that are in effect at the end of the previous month.

4.5 The ODUF feed will contain both rated and unrated messages. All messages will be in the standard Alliance for Telecommunications Industry Solutions (ATIS) EMI record format.

4.6 Messages that error in the billing system of Local Line will be the responsibility of Local Line. If, however, Local Line should encounter significant volumes of errored messages that prevent processing by Local Line within its systems, BellSouth will work with Local Line to determine the source of the errors and the appropriate resolution.

4.7 The following specifications shall apply to the ODUF feed.

4.7.1 ODUF Messages to be Transmitted

4.7.1.1 The following messages recorded by BellSouth will be transmitted to Local Line:

- 4.7.1.1.1 Message recording for per use/per activation type services (examples:  
Three -Way Calling, Verify, Interrupt, Call Return, etc.)
- 4.7.1.1.2 Measured billable Local
- 4.7.1.1.3 **Directory Assistance** messages
- 4.7.1.1.4 IntraLATA Toll
- 4.7.1.1.5 WATS and 800 Service
- 4.7.1.1.6 N11
- 4.7.1.1.7 Information Service Provider Messages
- 4.7.1.1.8 Operator Services Messages
- 4.7.1.1.9 **Operator Services Message Attempted** Calls (Network Element only)
- 4.7.1.1.10 Credit/Cancel Records
- 4.7.1.1.11 Usage for Voice Mail Message Service
- 4.7.1.2 Rated Incollected (messages BellSouth receives from other revenue accounting offices) can also be on ODUF. Rated Incollected will be intermingled with BellSouth recorded rated and unrated usage. Rated Incollected will not be packed separately.
- 4.7.1.3 BellSouth will perform duplicate record checks on records processed to ODUF. Any duplicate messages detected will be deleted and not sent to Local Line.
- 4.7.1.4 In the event that Local Line detects a duplicate on ODUF they receive from BellSouth, Local Line will drop the duplicate message and will not return the duplicate to BellSouth.
- 4.7.2 ODUF Physical File Characteristics
- 4.7.2.1 ODUF will be distributed to Local Line via CONNECT:Direct, Secure File Transfer Protocol (FTP) or another mutually agreed medium. The ODUF feed will be a variable block format. The data on the ODUF feed will be in a non-compacted EMI format (175 byte format plus modules). It will be created on a daily basis Monday through Friday except holidays. Details such as dataset name and delivery schedule will be addressed during negotiations of the distribution medium. There will be a maximum of one dataset per workday per OCN.
- 4.7.2.2 Data circuits (private line or dial-up) will be required between BellSouth and Local Line for the purpose of data transmission as set forth in Section 3.10.1 above.

- 4.7.2.3 If Local Line utilizes Secure File Transfer Protocol (FTP) for data file transmission, purchase of the Secure File Transfer Protocol (FTP) software will be the responsibility of Local Line.
- 4.7.3 ODUF Packing Specifications
  - 4.7.3.1 A pack will contain a minimum of one message record or a maximum of 99,999 message records plus a pack header record and a pack trailer record. One transmission can contain a maximum of 99 packs and a minimum of one pack.
  - 4.7.3.2 The OCN, From RAO, and Invoice Number will control the invoice sequencing. The From RAO will be used to identify to Local Line which BellSouth RAO that is sending the message. BellSouth and Local Line will use the invoice sequencing to control data exchange. BellSouth will be notified of sequence failures identified by Local Line and resend the data as appropriate.  
The data will be packed using ATIS EMI records.
- 4.7.4 ODUF Pack Rejection
  - 4.7.4.1 Local Line will notify BellSouth within one business day of rejected packs (via the mutually agreed medium). Packs could be rejected because of pack sequencing discrepancies or a critical edit failure on the Pack Header or Pack Trailer records (i.e. out-of-balance condition on grand totals, invalid data populated). Standard ATIS EMI error codes will be used. Local Line will not be required to return the actual rejected data to BellSouth. Rejected packs will be corrected and retransmitted to Local Line by BellSouth.
- 4.7.5 ODUF Control Data
  - 4.7.5.1 Local Line will send one confirmation record per pack that is received from BellSouth. This confirmation record will indicate Local Line's receipt of the pack and acceptance or rejection of the pack. Pack Status Code(s) will be populated using standard ATIS EMI error codes for packs that were rejected by Local Line for reasons stated in the above section.
- 4.7.6 ODUF Testing
  - 4.7.6.1 Upon request from Local Line, BellSouth shall send ODUF test files to Local Line. The Parties agree to review and discuss the ODUF content and/or format. For testing of usage results, BellSouth shall request that Local Line set up a production (live) file. The live test may consist of Local Line's employees making test calls for the types of services Local Line requests on ODUF. These test calls are logged by Local Line, and the logs are provided to BellSouth. These logs will be used to verify the files. Testing will be completed within 30 calendar days from the date on which the initial test file was sent.

**5. ACCESS DAILY USAGE FILE**

- 5.1 Upon written request from Local Line, BellSouth will provide the Access Daily Usage File (ADUF) service to Local Line pursuant to the terms and conditions set forth in this section.
- 5.2 Local Line shall furnish all relevant information required by BellSouth for the provision of ADUF.
- 5.3 ADUF will contain access messages associated with a port that Local Line has purchased from BellSouth
- 5.4 Charges for ADUF will appear on Local Line's monthly bills for the previous month's usage. The charges are as set forth in Exhibit A to this Attachment. Local Line will be billed at the ADUF rates that are in effect at the end of the previous month.
- 5.5 Messages that error in the billing system of Local Line will be the responsibility of Local Line. If, however, Local Line should encounter significant volumes of errored messages that prevent processing by Local Line within its systems, BellSouth will work with Local Line to determine the source of the errors and the appropriate resolution.
- 5.6 ADUF Messages To Be Transmitted
  - 5.6.1 The following messages recorded by BellSouth will be transmitted to Local Line:
    - 5.6.1.1 Recorded originating and terminating interstate and intrastate access records associated with a port.
    - 5.6.1.2 Recorded terminating access records for undetermined jurisdiction access records associated with a port.
  - 5.6.2 BellSouth will perform duplicate record checks on records processed to ADUF. Any duplicate messages detected will be dropped and not sent to Local Line.
  - 5.6.3 In the event that Local Line detects a duplicate on ADUF they receive from BellSouth, Local Line will drop the duplicate message and will not return the duplicate to BellSouth.
  - 5.6.4 ADUF Physical File Characteristics
    - 5.6.4.1 ADUF will be distributed to Local Line via CONNECT:Direct, Secure File Transfer Protocol (FTP) or another mutually agreed medium. The ADUF feed will be a fixed block format. The data on the ADUF feed will be in a non-compacted EMI format (210 byte). It will be created on a daily basis Monday through Friday except holidays. Details such as dataset name and delivery schedule will be addressed during negotiations of the distribution medium. There will be a maximum of one dataset per workday per OCN.



- 5.6.4.2 Data circuits (private line or dial-up) will be required between BellSouth and Local Line for the purpose of data transmission as set forth in Section 3.10.1 above.
- 5.6.4.3 If Local Line utilizes Secure File Transfer Protocol (FTP) for data file transmission, purchase of the Secure File Transfer Protocol (FTP) software will be the responsibility of Local Line.
- 5.6.5 ADUF Packing Specifications
  - 5.6.5.1 A pack will contain a minimum of one message record or a maximum of 99,999 message records plus a pack header record and a pack trailer record. One transmission can contain a maximum of 99 packs and a minimum of one pack.
  - 5.6.5.2 The OCN, From RAO, and Invoice Number will control the invoice sequencing. The From RAO will be used to identify to Local Line which BellSouth RAO is sending the message. BellSouth and Local Line will use the invoice sequencing to control data exchange. BellSouth will be notified of sequence failures identified by Local Line and resend the data as appropriate.  
The data will be packed using ATIS EMI records.
- 5.6.6 ADUF Pack Rejection
  - 5.6.6.1 Local Line will notify BellSouth within one business day of rejected packs (via the mutually agreed medium). Packs could be rejected because of pack sequencing discrepancies or a critical edit failure on the Pack Header or Pack Trailer records (i.e. out-of-balance condition on grand totals, invalid data populated). Standard ATIS EMI error codes will be used. Local Line will not be required to return the actual rejected data to BellSouth. Rejected packs will be corrected and retransmitted to Local Line by BellSouth.
- 5.6.7 ADUF Control Data
  - 5.6.7.1 Local Line will send one confirmation record per pack that is received from BellSouth. This confirmation record will indicate Local Line's receipt of the pack and acceptance or rejection of the pack. Pack Status Code(s) will be populated using standard ATIS EMI error codes for packs that were rejected by Local Line for reasons stated in the above section.
- 5.6.8 ADUF Testing
  - 5.6.8.1 Upon request from Local Line, BellSouth shall send a test file of generic data to Local Line via Connect:Direct or Text File via E-Mail. The Parties agree to review and discuss the test file's content and/or format.
- 6. ENHANCED OPTIONAL DAILY USAGE FILE (EODUF)**

- 6.1 Upon written request from Local Line, BellSouth will provide the Enhanced Optional Daily Usage File (EODUF) service to Local Line pursuant to the terms and conditions set forth in this section. EODUF will only be sent to existing ODUF subscribers who request the EODUF option.
- 6.2 Local Line shall furnish all relevant information required by BellSouth for the provision of the Enhanced Optional Daily Usage File.
- 6.3 The Enhanced Optional Daily Usage File (EODUF) will provide usage data for local calls originating from resold Flat Rate Business and Residential Lines.
- 6.4 Charges for delivery of the Enhanced Optional Daily Usage File will appear on Local Line's monthly bills for the previous month's usage. The charges are as set forth in Exhibit A to this Attachment. Local Line will be billed at the EODUF rates that are in effect at the end of the previous month.
- 6.5 All messages will be in the standard Alliance for Telecommunications Industry Solutions (ATIS) EMI record format.
- 6.6 Messages that error in the billing system of Local Line will be the responsibility of Local Line. If, however, Local Line should encounter significant volumes of errored messages that prevent processing by Local Line within its systems, BellSouth will work with Local Line to determine the source of the errors and the appropriate resolution.
- 6.7 The following specifications shall apply to the EODUF feed.
  - 6.7.1 Usage To Be Transmitted
    - 6.7.1.1 The following messages recorded by BellSouth will be transmitted to Local Line:
      - 6.7.1.1.1 Customer usage data for flat rated local call originating from Local Line's End User lines (1FB or 1FR). The EODUF record for flat rate messages will include:
        - 6.7.1.1.2 Date of Call
        - 6.7.1.1.3 From Number
        - 6.7.1.1.4 To Number
        - 6.7.1.1.5 Connect Time
        - 6.7.1.1.6 Conversation Time
        - 6.7.1.1.7 Method of Recording
        - 6.7.1.1.8 From RAO

- 6.7.1.1.9 Rate Class
- 6.7.1.1.10 Message Type
- 6.7.1.1.11 Billing Indicators
- 6.7.1.1.12 Bill to Number
- 6.7.1.2 BellSouth will perform duplicate record checks on EODUF records processed to Optional Daily Usage File. Any duplicate messages detected will be deleted and not sent to Local Line.
- 6.7.1.3 In the event that Local Line detects a duplicate on Enhanced Optional Daily Usage File they receive from BellSouth, Local Line will drop the duplicate message (Local Line will not return the duplicate to BellSouth).
- 6.7.2 Physical File Characteristics
  - 6.7.2.1 The EODUF feed will be distributed to Local Line over their existing Optional Daily Usage File (ODUF) feed. The EODUF messages will be intermingled among Local Line's Optional Daily Usage File (ODUF) messages. The EODUF will be a variable block format (2476) with an LRECL of 2472. The data on the EODUF will be in a non-compacted EMI format (175 byte format plus modules). It will be created on a daily basis (Monday through Friday except holidays).
  - 6.7.2.2 Data circuits (private line or dial-up) may be required between BellSouth and Local Line for the purpose of data transmission. Where a dedicated line is required, Local Line will be responsible for ordering the circuit, overseeing its installation and coordinating the installation with BellSouth. Local Line will also be responsible for any charges associated with this line. Equipment required on the BellSouth end to attach the line to the mainframe computer and to transmit successfully ongoing will be negotiated on an individual case basis. Where a dial-up facility is required, dial circuits will be installed in the BellSouth data center by BellSouth and the associated charges assessed to Local Line. Additionally, all message toll charges associated with the use of the dial circuit by Local Line will be the responsibility of Local Line. Associated equipment on the BellSouth end, including a modem, will be negotiated on an individual case basis between the Parties. All equipment, including modems and software, that is required on Local Line's end for the purpose of data transmission will be the responsibility of Local Line.
- 6.7.3 Packing Specifications
  - 6.7.3.1 A pack will contain a minimum of one message record or a maximum of 99,999 message records plus a pack header record and a pack trailer record. One transmission can contain a maximum of 99 packs and a minimum of one pack.

- 6.7.3.2 The Operating Company Number (OCN), From Revenue Accounting Office (RAO), and Invoice Number will control the invoice sequencing. The From RAO will be used to identify to Local Line which BellSouth RAO is sending the message. BellSouth and Local Line will use the invoice sequencing to control data exchange. BellSouth will be notified of sequence failures identified by Local Line and resend the data as appropriate.
- 6.7.3.3 The data will be packed using ATIS EMI records.

ODUF/ADUF/CMDS - Florida

CATEGORY	RATE ELEMENTS	Interim	Zone	BCS	USOC	RATES (\$)	Svc Order Submitted Elec per LSR	Svc Order Submitted Manually per LSR	Attachment: 7		Exhibit: A	
									Incremental Charge - Manual Svc Order vs. Electronic-1st	Incremental Charge - Manual Svc Order vs. Electronic-Add'l	Incremental Charge - Manual Svc Order vs. Electronic-Disc 1st	Incremental Charge - Manual Svc Order vs. Electronic-Disc Add'l
									Rec	Nonrecurring		Nonrecurring Disconnect
	First	Add'l	First	Add'l	SOMEc	SOMAN	SOMAN	SOMAN	SOMAN	SOMAN	SOMAN	
<b>ODUF/ADUF/CMDS</b>												
	<b>ACCESS DAILY USAGE FILE (ADUF)</b>											
	ADUF: Message Processing, per message					0.001656						
	ADUF: Data Transmission (CONNECT:DIRECT), per message					0.0001245						
	<b>OPTIONAL DAILY USAGE FILE (ODUF)</b>											
	ODUF: Recording, per message					0.0000071						
	ODUF: Message Processing, per message					0.002146						
	ODUF: Message Processing, per Magnetic Tape provisioned					35.91						
	ODUF: Data Transmission (CONNECT:DIRECT), per message					0.00010375						
	<b>CENTRALIZED MESSAGE DISTRIBUTION SERVICE (CMDS)</b>											
	CMDS: Message Processing, per message					0.004						
	CMDS: Data Transmission (CONNECT:DIRECT), per message					0.001						
Notes: If no rate is identified in the contract, the rate for the specific service or function will be as set forth in applicable BellSouth tariff or as negotiated by the Parties upon request by either Party.												

**Attachment 8**

**Rights-of-Way, Conduits and Pole Attachments**

**Rights-of-Way, Conduits and  
Pole Attachments**

BellSouth will provide nondiscriminatory access to any pole, duct, conduit, or right-of-way owned or controlled by BellSouth pursuant to 47 U.S.C. § 224, as amended by the Act, pursuant to terms and conditions of a license agreement subsequently negotiated with BellSouth's Competitive Structure Provisioning Center.

**Attachment 9**  
**Performance Measurements**



## **PERFORMANCE MEASUREMENTS**

Upon a particular Commission's issuance of an Order pertaining to Performance Measurements in a proceeding expressly applicable to all CLECs generally, BellSouth shall implement in that state such Performance Measurements as of the date specified by the Commission. Performance Measurements that have been Ordered in a particular state can currently be accessed via the internet at <http://pmap.bellsouth.com>.

**Attachment 10**  
**BellSouth Disaster Recovery Plan**

<u>CONTENTS</u>		<u>PAGE</u>
1.0	Purpose	2
2.0	Single Point of Contact	2
3.0	Identifying the Problem	2
	3.1 Site Control	3
	3.2 Environmental Concerns	4
4.0	The Emergency Control Center (ECC)	4
5.0	Recovery Procedures	5
	5.1 CLEC Outage	5
	5.2 BellSouth Outage	5
	5.2.1 Loss of Central Office	6
	5.2.2 Loss of a Central Office with Serving Wire Center Functions	6
	5.2.3 Loss of a Central Office with Tandem Functions	6
	5.2.4 Loss of a Facility Hub	7
	5.3 Combined Outage (CLEC and BellSouth Equipment)	7
6.0	T1 Identification Procedures	7
7.0	Acronyms	8

## **1.0 PURPOSE**

In the unlikely event of a disaster occurring that affects BellSouth's long-term ability to deliver traffic to a Competitive Local Exchange Carrier (CLEC), general procedures have been developed by BellSouth to hasten the recovery process in accordance with the Telecommunications Service Priority (TSP) Program established by the Federal Communications Commission to identify and prioritize telecommunication services that support national security or emergency preparedness (NS/EP) missions. Since each location is different and could be affected by an assortment of potential problems, a detailed recovery plan is impractical. However, in the process of reviewing recovery activities for specific locations, some basic procedures emerge that appear to be common in most cases.

These general procedures should apply to any disaster that affects the delivery of traffic for an extended time period. Each CLEC will be given the same consideration during an outage, and service will be restored as quickly as possible.

This document will cover the basic recovery procedures that would apply to every CLEC.

## **2.0 SINGLE POINT OF CONTACT**

When a problem is experienced, regardless of the severity, the BellSouth Network Management Center (NMC) will observe traffic anomalies and begin monitoring the situation. Controls will be appropriately applied to insure the sanity of BellSouth's network; and, in the event that a switch or facility node is lost, the NMC will attempt to circumvent the failure using available reroutes.

BellSouth's NMC will remain in control of the restoration efforts until the problem has been identified as being a long-term outage. At that time, the NMC will contact BellSouth's Emergency Control Center (ECC) and relinquish control of the recovery efforts. Even though the ECC may take charge of the situation, the NMC will continue to monitor the circumstances and restore traffic as soon as damaged network elements are revitalized.

**The telephone number for the BellSouth Network Management Center in Atlanta, as published in Telcordia's National Network Management Directory, is 404-321-2516.**

## **3.0 IDENTIFYING THE PROBLEM**

During the early stages of problem detection, the NMC will be able to tell which CLECs are affected by the catastrophe. Further analysis and/or first hand observation will determine if the disaster has affected CLEC equipment only, BellSouth equipment only or a combination. The initial restoration activity will be largely determined by the equipment that is affected.

Once the nature of the disaster is determined and after verifying the cause of the problem, the NMC will initiate reroutes and/or transfers that are jointly agreed upon by the affected CLECs' Network Management Center and the BellSouth NMC. The type and percentage of controls used will depend upon available network capacity. Controls necessary to stabilize the situation will be invoked and the NMC will attempt to re-establish as much traffic as possible.

For long-term outages, recovery efforts will be coordinated by the Emergency Control Center (ECC). Traffic controls will continue to be applied by the NMC until facilities are re-established. As equipment is made available for service, the ECC will instruct the NMC to begin removing the controls and allow traffic to resume.

### **3.1 SITE CONTROL**

In the total loss of building use scenario, what likely exists will be a smoking pile of rubble. This rubble will contain many components that could be dangerous. It could also contain any personnel on the premises at the time of the disaster. For these reasons, the local fire marshal with the assistance of the police will control the site until the building is no longer a threat to surrounding properties and the companies have secured the site from the general public.

During this time, the majority owner of the building should be arranging for a demolition contractor to mobilize to the site with the primary objective of reaching the cable entrance facility for a damage assessment. The results of this assessment would then dictate immediate plans for restoration, both short term and permanent.

In a less catastrophic event, i.e., the building is still standing and the cable entrance facility is usable, the situation is more complex. The site will initially be controlled by local authorities until the threat to adjacent property has diminished. Once the site is returned to the control of the companies, the following events should occur.

An initial assessment of the main building infrastructure systems (mechanical, electrical, fire and life safety, elevators, and others) will establish building needs. Once these needs are determined, the majority owner should lead the building restoration efforts. There may be situations where the site will not be totally restored within the confines of the building. The companies must individually determine their needs and jointly assess the cost of permanent restoration to determine the overall plan of action.

Multiple restoration trailers from each company will result in the need for designated space and installation order. This layout and control is required to maximize the amount of restoration equipment that can be placed at the site, and the priority of placements.

Care must be taken in this planning to ensure other restoration efforts have logistical access to the building. Major components of telephone and building equipment will need to be removed and replaced. A priority for this equipment must also be jointly established to facilitate overall site restoration. (Example: If the AC switchgear has sustained damage, this would be of the highest priority in order to regain power, lighting, and HVAC throughout the building.)

If the site will not accommodate the required restoration equipment, the companies would then need to quickly arrange with local authorities for street closures, rights of way or other possible options available.

### 3.2 ENVIRONMENTAL CONCERNS

In the worse case scenario, many environmental concerns must be addressed. Along with the police and fire marshal, the state environmental protection department will be on site to monitor the situation.

Items to be concerned with in a large central office building could include:

1. Emergency engine fuel supply. Damage to the standby equipment and the fuel handling equipment could have created "spill" conditions that have to be handled within state and federal regulations.
2. Asbestos-containing materials that may be spread throughout the wreckage. Asbestos could be in many components of building, electrical, mechanical, outside plant distribution, and telephone systems.
3. Lead and acid. These materials could be present in potentially large quantities depending upon the extent of damage to the power room.
4. Mercury and other regulated compounds resident in telephone equipment.
5. Other compounds produced by the fire or heat.

Once a total loss event occurs at a large site, local authorities will control immediate clean up (water placed on the wreckage by the fire department) and site access.

At some point, the companies will become involved with local authorities in the overall planning associated with site clean up and restoration. Depending on the clean up approach taken, delays in the restoration of several hours to several days may occur.

In a less severe disaster, items listed above are more defined and can be addressed individually depending on the damage.

In each case, the majority owner should coordinate building and environmental restoration as well as maintain proper planning and site control.

### 4.0 THE EMERGENCY CONTROL CENTER (ECC)

The ECC is located in the Midtown 1 Building in Atlanta, Georgia. During an emergency, the ECC staff will convene a group of pre-selected experts to inventory the damage and initiate corrective actions. These experts have regional access to BellSouth's personnel and equipment and will assume control of the restoration activity anywhere in the nine-state area.

In the past, the ECC has been involved with restoration activities resulting from hurricanes, ice storms and floods. They have demonstrated their capabilities during these calamities as well as

during outages caused by human error or equipment failures. This group has an excellent record of restoring service as quickly as possible.

During a major disaster, the ECC may move emergency equipment to the affected location, direct recovery efforts of local personnel and coordinate service restoration activities with the CLECs. The ECC will attempt to restore service as quickly as possible using whatever means is available, leaving permanent solutions, such as the replacement of damaged buildings or equipment, for local personnel to administer.

Part of the ECC's responsibility, after temporary equipment is in place, is to support the NMC efforts to return service to the CLECs. Once service has been restored, the ECC will return control of the network to normal operational organizations. Any long-term changes required after service is restored will be made in an orderly fashion and will be conducted as normal activity.

## **5.0 RECOVERY PROCEDURES**

The nature and severity of any disaster will influence the recovery procedures. One crucial factor in determining how BellSouth will proceed with restoration is whether or not BellSouth's equipment is incapacitated. Regardless of whose equipment is out of service, BellSouth will move as quickly as possible to aid with service recovery; however, the approach that will be taken may differ depending upon the location of the problem.

### **5.1 CLEC OUTAGE**

For a problem limited to one CLEC (or a building with multiple CLECs), BellSouth has several options available for restoring service quickly. For those CLECs that have agreements with other CLECs, BellSouth can immediately start directing traffic to a provisional CLEC for completion. This alternative is dependent upon BellSouth having concurrence from the affected CLECs.

Whether or not the affected CLECs have requested a traffic transfer to another CLEC will not impact BellSouth's resolve to re-establish traffic to the original destination as quickly as possible.

### **5.2 BELLSOUTH OUTAGE**

Because BellSouth's equipment has varying degrees of impact on the service provided to the CLECs, restoring service from damaged BellSouth equipment is different. The outage will probably impact a number of Carriers simultaneously. However, the ECC will be able to initiate immediate actions to correct the problem.

A disaster involving any of BellSouth's equipment locations could impact the CLECs, some more than others. A disaster at a Central Office (CO) would only impact the delivery of traffic to and from that one location, but the incident could affect many Carriers. If the Central Office is a Serving Wire Center (SWC), then traffic from the entire area to those Carriers served from that switch would also be impacted. If the switch functions as an Access Tandem, or there is a tandem in the building, traffic from every CO to every CLEC could be interrupted. A disaster that destroys a facility hub could disrupt various traffic flows, even though the switching equipment may be unaffected.

The NMC would be the first group to observe a problem involving BellSouth's equipment. Shortly after a disaster, the NMC will begin applying controls and finding re-routes for the

completion of as much traffic as possible. These reroutes may involve delivering traffic to alternate Carriers upon receiving approval from the CLECs involved. In some cases, changes in translations will be required. If the outage is caused by the destruction of equipment, then the ECC will assume control of the restoration.

### **5.2.1 Loss of a Central Office**

When BellSouth loses a Central Office, the ECC will

- a) Place specialists and emergency equipment on notice;
- b) Inventory the damage to determine what equipment and/or functions are lost;
- c) Move containerized emergency equipment and facility equipment to the stricken area, if necessary;
- d) Begin reconnecting service on a parity basis for Hospitals, Police and other emergency agencies or End Users served by BellSouth or CLEC in accordance with the TSP priority restoration coding scheme entered in the BellSouth Maintenance database immediately prior to the emergency.

### **5.2.2 Loss of a Central Office with Serving Wire Center Functions**

The loss of a Central Office that also serves as a Serving Wire Center (SWC) will be restored as described in Section 5.2.1.

### **5.2.3 Loss of a Central Office with Tandem Functions**

When BellSouth loses a Central Office building that serves as an Access Tandem and as a SWC, the ECC will

- a) Place specialists and emergency equipment on notice;
- b) Inventory the damage to determine what equipment and/or functions are lost;
- c) Move containerized emergency equipment and facility equipment to the stricken area, if necessary;
- d) Begin reconnecting service on a parity basis for Hospitals, Police and other emergency agencies or End Users served by BellSouth or CLEC in accordance with the TSP priority restoration coding scheme entered in the BellSouth Maintenance database immediately prior to the emergency;
- e) Re-direct as much traffic as possible to the alternate access tandem (if available) for delivery to those CLECs utilizing a different location as a SWC;
- f) Begin aggregating traffic to a location near the damaged building. From this location, begin re-establishing trunk groups to the CLECs for the delivery of traffic normally found on the direct trunk groups. (This aggregation point may be the alternate access tandem location or another CO on a primary facility route.)

#### **5.2.4 Loss of a Facility Hub**

In the event that BellSouth loses a facility hub, the recovery process is much the same as above. Once the NMC has observed the problem and administered the appropriate controls, the ECC will assume authority for the repairs. The recovery effort will include

- a) Placing specialists and emergency equipment on notice;
- b) Inventorying the damage to determine what equipment and/or functions are lost;
- c) Moving containerized emergency equipment to the stricken area, if necessary;
- d) Reconnecting service on a parity basis for Hospitals, Police and other emergency agencies or End Users served by BellSouth or CLEC in accordance with the TSP priority restoration coding scheme entered in the BellSouth Maintenance database immediately prior to the emergency; and
- e) If necessary, BellSouth will aggregate the traffic at another location and build temporary facilities. This alternative would be viable for a location that is destroyed and building repairs are required.

#### **5.3 COMBINED OUTAGE (CLEC AND BELLSOUTH EQUIPMENT)**

In some instances, a disaster may impact BellSouth's equipment as well as the CLECs'. This situation will be handled in much the same way as described in Section 5.2.3. Since BellSouth and the CLECs will be utilizing temporary equipment, close coordination will be required.

#### **6.0 T1 IDENTIFICATION PROCEDURES**

During the restoration of service after a disaster, BellSouth may be forced to aggregate traffic for delivery to a CLEC. During this process, T1 traffic may be consolidated onto DS3s and may become unidentifiable to the Carrier. Because resources will be limited, BellSouth may be forced to "package" this traffic entirely differently than normally received by the CLECs. Therefore, a method for identifying the T1 traffic on the DS3s and providing the information to the Carriers is required.



## 7.0 ACRONYMS

CLEC	-	Competitive Local Exchange Carrier
CO	-	Central Office (BellSouth)
DS3	-	Facility that carries 28 T1s (672 circuits)
ECC	-	Emergency Control Center (BellSouth)
NMC	-	Network Management Center
SWC	-	Serving Wire Center (BellSouth switch)
T1	-	Facility that carries 24 circuits
TSP	-	Telecommunications Service Priority

### **Hurricane Information**

During a hurricane, BellSouth will make every effort to keep CLECs updated on the status of our network. Information centers will be set up throughout BellSouth Telecommunications. These centers are not intended to be used for escalations, but rather to keep the CLEC informed of network related issues, area damages and dispatch conditions, etc.

Hurricane-related information can also be found on line at [http://www.interconnection.bellsouth.com/network/disaster/dis\\_resp.htm](http://www.interconnection.bellsouth.com/network/disaster/dis_resp.htm). Information concerning Mechanized Disaster Reports can also be found at this website by clicking on CURRENT MDR REPORTS or by going directly to <http://www.interconnection.bellsouth.com/network/disaster/mdrs.htm>.

### **BST Disaster Management Plan**

BellSouth maintenance centers have geographical and redundant communication capabilities. In the event of a disaster removing any maintenance center from service another geographical center would assume maintenance responsibilities. The contact numbers will not change and the transfer will be transparent to the CLEC.

**Attachment 11**

**Bona Fide Request and New Business Request Process**

**BONA FIDE REQUEST AND NEW BUSINESS REQUEST PROCESS**

1.0 The Parties agree that Local Line is entitled to order any Unbundled Network Element, Interconnection option, service option or Resale Service required to be made available by FCC or Commission requirements pursuant to the Communications Act of 1934, as modified by the Telecommunications Act of 1996 (the "Act"). Local Line also shall be permitted to request the development of new or revised facilities or service options which are not required by the Act. Procedures applicable to requesting the addition of such facilities or service options are specified in this Attachment 11.

2.0 **BONA FIDE REQUEST**

2.1 A Bona Fide Request (BFR) is to be used when Local Line makes a request of BellSouth to provide a new or modified Unbundled Network Element, Interconnection option, or other service option (Requested Services) pursuant to the Act that was not previously included in this Agreement.

2.2 A BFR shall be submitted in writing by Local Line and shall specifically identify the requested service date, technical requirements, space requirements and/or such other specifications that clearly define the request such that BellSouth has sufficient information to analyze and prepare a response. Such a request shall also include Local Line's designation of the request as being pursuant to the Telecommunications Act of 1996 (i.e. a BFR). The request shall be sent to Local Line's designated BellSouth Sales contact.

2.3 If BellSouth determines that the preliminary analysis of the requested BFR is of such complexity that it will cause BellSouth to expend inordinate resources to evaluate the BFR, BellSouth shall notify Local Line within ten (10) business days of BellSouth's receipt of BFR that a fee will be required prior to the evaluation of the BFR. Local Line shall submit such fee within thirty (30) business days of BellSouth's notice that a fee is required. Within thirty (30) business days of BellSouth's receipt of the fee, BellSouth shall respond to Local Line by providing a preliminary analysis of such Requested Services that are the subject of the BFR. The preliminary analysis shall either confirm that BellSouth will offer access to the Requested Services or confirm that BellSouth will not offer the Requested Services. If the preliminary analysis states that BellSouth will not offer the Requested Services, BellSouth will provide an explanation of

why the request is not technically feasible; does not qualify as a BFR for the Requested Services or is otherwise not required to be provided under the Act. If preliminary analysis of the requested BFR is not of such complexity that it will cause BellSouth to expend inordinate resources to evaluate the BFR, within thirty (30) business days of its receipt of the BFR, BellSouth shall respond to Local Line by providing a preliminary analysis of such Requested Services that are the subject of the BFR. The preliminary analysis shall either confirm that BellSouth will offer access to the Requested Services or confirm that BellSouth will not offer the Requested Services. If the preliminary analysis states that BellSouth will not offer the Requested Services, BellSouth will provide an explanation of why the request is not technically feasible, does not qualify as a BFR for the Requested Services or is otherwise not required to be provided under the Act.

- 2.4 Local Line may cancel a BFR at any time. If Local Line cancels the request more than ten (10) business days after submitting the BFR request, Local Line shall pay BellSouth's reasonable and demonstrable costs of processing and/or implementing the BFR up to the date of cancellation in addition to any fee submitted in accordance with Section 2.3 above.
- 2.5 Local Line will have thirty (30) business days from receipt of preliminary analysis to accept the preliminary analysis or cancel the BFR as set forth in Section 2.4. Acceptance of the preliminary analysis must be in writing and accompanied by all nonrecurring charges quoted in the preliminary analysis. The nonrecurring charges as stated in the preliminary analysis cover the initial work required to develop the project plan, create the design parameters, and establish all activities and resources required to complete the BFR (Development Costs). Development costs are non-refundable. If Local Line fails to respond within this 30-day period, the BFR will be deemed cancelled.
  - 2.5.1 BellSouth shall propose a firm price quote and a detailed implementation plan within thirty (30) business days of receipt of Local Line's acceptance of the preliminary analysis.
  - 2.5.2 Local Line shall have thirty (30) business days from receipt of firm price quote to accept or deny the firm price quote and submit any additional nonrecurring, non-refundable fees quoted in the firm price quote.
- 2.6 Unless Local Line agrees otherwise, all prices shall be consistent with the pricing principles of the Act, FCC and/or the Commission.
- 2.7 If Local Line believes that BellSouth's firm price quote is not consistent with the requirements of the Act, or if either Party believes that the other

is not acting in good faith in requesting, negotiating or processing the BFR, either Party may seek FCC or Commission arbitration, as appropriate, to resolve the dispute. Any such arbitration applicable to Unbundled Network Elements and/or Interconnection shall be conducted in accordance with standards prescribed in Section 252 of the Act.

2.8 Upon agreement to the rates, terms and conditions of a BFR, an amendment to this Agreement may be required.

### 3.0 **NEW BUSINESS REQUEST**

3.1 A New Business Request (NBR) is to be used by Local Line to make a request of BellSouth for a new or modified feature or capability of an existing product or service, a new product or service that is not deployed within the BellSouth network or operations and business support systems, or a new or modified service option that was not previously included in this Agreement (Requested Enhanced Services).

3.2 An NBR shall be submitted in writing by Local Line and shall specifically identify the requested service date, technical requirements, space requirements and/or such specifications that clearly define the request such that BellSouth has sufficient information to analyze and prepare a response. The request shall be sent to Local Line's designated BellSouth Sales contact.

3.3 If BellSouth determines that the preliminary analysis of the requested NBR is of such complexity that it will cause BellSouth to expend inordinate resources to evaluate the NBR, BellSouth shall notify Local Line that a fee will be required prior to the evaluation of the NBR. Local Line shall submit such fee within ten (10) business days of BellSouth's notice that a fee is required. BellSouth shall use reasonable efforts to respond to the NBR within (30) business days following BellSouth's receipt of the fee by providing a preliminary analysis of such Requested Enhanced Services that are the subject of the NBR. The preliminary analysis shall either confirm that BellSouth will offer access to the Requested Enhanced Services or confirm that BellSouth will not offer the Requested Enhanced Services. If the preliminary analysis states that BellSouth will not offer the Requested Services, BellSouth will provide an explanation of why the request is not technically feasible, does not qualify as an NBR for the Requested Services or is otherwise not required to be provided under the Act. If preliminary analysis of the requested NBR is not of such complexity that it will cause BellSouth to expend inordinate resources to evaluate the NBR, BellSouth will use reasonable efforts to respond to Local Line within thirty (30) business days of its receipt of an NBR by providing a preliminary analysis of such Requested Services that are the

subject of the NBR. The preliminary analysis shall either confirm that BellSouth will offer access to the Requested Enhanced Services or confirm that BellSouth will not offer the Requested Enhanced Services. If the preliminary analysis states that BellSouth will not offer the Requested Services, BellSouth will provide an explanation of why the request is not technically feasible, does not qualify as an NBR for the Requested Services or is otherwise not required to be provided under the Act.

- 3.4 Local Line may cancel an NBR at any time. If Local Line cancels the request more than ten (10) business days after submitting it, Local Line shall pay BellSouth's reasonable and demonstrable costs of processing and/or implementing the NBR up to the date of cancellation in addition to any fee submitted in accordance with Section 3.3 above.
- 3.5 Local Line will have thirty (30) business days from receipt of preliminary analysis to accept the preliminary analysis or cancel the NBR as set forth in section 3.4. Acceptance of the preliminary analysis must be in writing and accompanied by all nonrecurring charges quoted in the preliminary analysis. The nonrecurring charges as stated in the preliminary analysis cover the initial work required to develop the project plan, create the design parameters, and establish all activities and resources required to complete the NBR. If Local Line fails to respond within this 30-day period, the NBR will be deemed cancelled.
- 3.6 If Local Line accepts the preliminary analysis, BellSouth shall propose a firm price quote and a detailed implementation plan within sixty (60) business days of receipt of Local Line's acceptance of the preliminary analysis and nonrecurring fees quoted in the preliminary analysis.
- 3.7 Local Line shall have thirty (30) business days from receipt of the firm price quote to accept or deny the firm price quote and submit any additional nonrecurring, non-refundable fees quoted in the firm price quote.
- 3.8 Upon agreement to the terms of a NBR, an amendment to this Agreement, or a separate agreement, may be required.